

NCP1403

Boost Converter - PFM, DC-DC

15 V, 50 mA

The NCP1403 is a monolithic PFM step-up DC-DC converter. This device is designed to boost a single Lithium or two cell AA/AAA battery voltage up to 15 V (with internal MOSFET) output for handheld applications. A pullup Chip Enable feature is built with this device to extend battery-operating life. Besides, the device can also be incorporated in step-down, and voltage-inverting configurations. This device is available in space-saving TSOP-5 package.

Features

- 82% Efficiency at $V_{OUT} = 15\text{ V}$, $I_{OUT} = 50\text{ mA}$, $V_{IN} = 5.0\text{ V}$
- 78% Efficiency at $V_{OUT} = 15\text{ V}$, $I_{OUT} = 30\text{ mA}$, $V_{IN} = 3.6\text{ V}$
- Low Operating Current of $19\text{ }\mu\text{A}$ (No Switching)
- Low Shutdown Current of $0.3\text{ }\mu\text{A}$
- Low Startup Voltage of 1.3 V Typical at 0 mA
- Output Voltage up to 15 V with Built-in 16 V MOSFET Switch
- PFM Switching Frequency up to 300 kHz
- Chip Enable
- Low Profile and Minimum External Parts
- Micro Miniature TSOP-5 Package
- Pb-Free Package is Available

Typical Applications

- LCD Bias
- Personal Digital Assistants (PDA)
- Digital Still Camera
- Handheld Games
- Hand-held Instrument



ON Semiconductor®

<http://onsemi.com>



TSOP-5
SN SUFFIX
CASE 483

MARKING DIAGRAM AND PIN CONNECTIONS

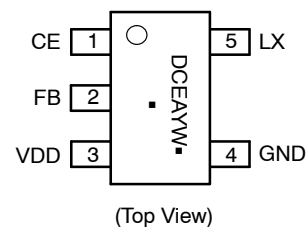

DCE=Specific Device Marking
A = Assembly Location
Y = Year
W = Work Week
▪ = Pb-Free Package
(Note: Microdot may be in either location)

ORDERING INFORMATION

Device	Package	Shipping†
NCP1403SNT1	TSOP-5	3000/Tape & Reel
NCP1403SNT1G	TSOP-5 (Pb-Free)	3000/Tape & Reel

†For information on tape and reel specifications, including part orientation and tape sizes, please refer to our Tape and Reel Packaging Specifications Brochure, BRD8011/D.

NCP1403

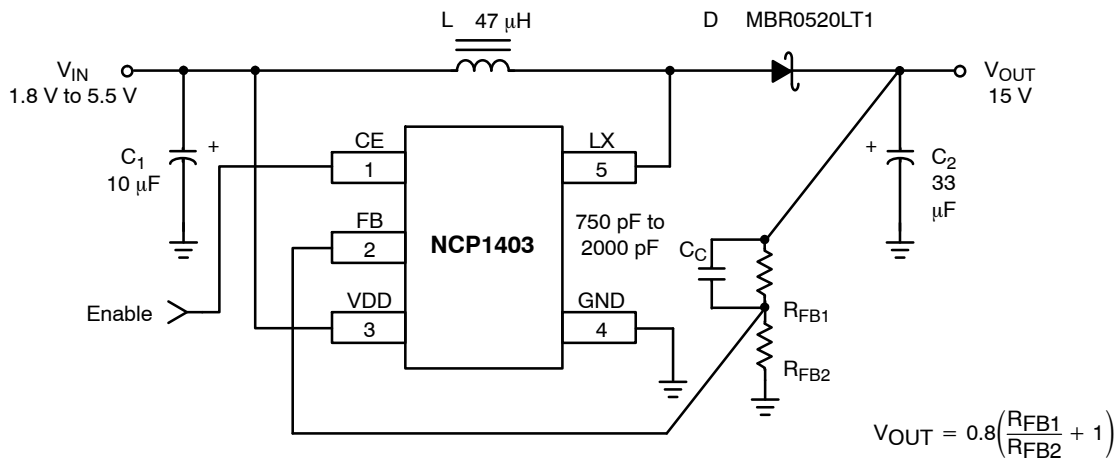

Figure 1. Typical Step-Up Application Circuit 1

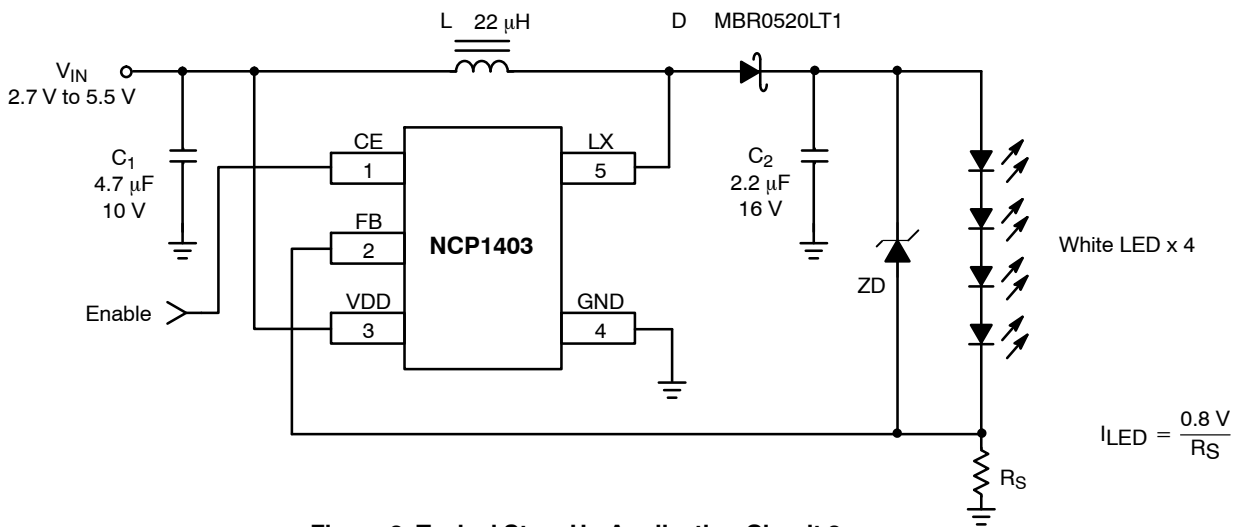

Figure 2. Typical Step-Up Application Circuit 2

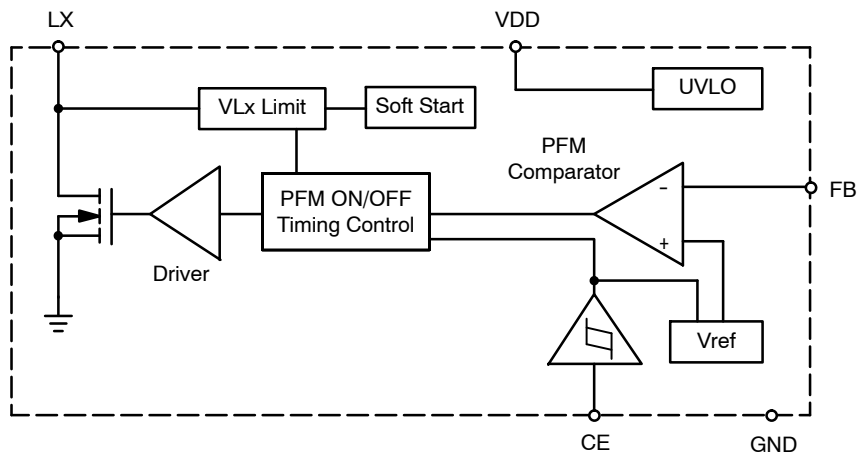

Figure 3. Representative Block Diagram

NCP1403

PIN FUNCTION DESCRIPTIONS

Pin	Symbol	Description
1	CE	Chip Enable Pin 1. The chip is enabled if a voltage which is equal to or greater than 0.9 V is applied. 2. The chip is disabled if a voltage which is less than 0.3 V is applied. 3. The chip will be enabled if it is left floating.
2	FB	PFM comparator inverting input, and is connected to off-chip resistor divider which sets output voltage.
3	VDD	Power supply pin for internal circuit.
4	GND	Ground pin.
5	LX	External inductor connection pin.

MAXIMUM RATINGS

Rating	Symbol	Value	Unit
Power Supply Voltage (Pin 3)	V_{DD}	-0.3 to 6.0	V
Input/Output Pin LX (Pin 5) LX Peak Sink Current FB (Pin 2)	V_{LX} I_{LX} V_{FB}	-0.3 to 16.0 600 -0.3 to 6.0	V mA V
CE (Pin 1) Input Voltage Range Input Current Range	V_{CE} I_{CE}	-0.3 to 6.0 150	V mA
Power Dissipation and Thermal Characteristics Maximum Power Dissipation @ $T_A = 25^\circ\text{C}$ Thermal Resistance Junction-to-Air	P_D $R_{\theta JA}$	500 250	mW $^\circ\text{C}/\text{W}$
Operating Ambient Temperature Range	T_A	-40 to +85	$^\circ\text{C}$
Operating Junction Temperature Range	T_J	-40 to +150	$^\circ\text{C}$
Storage Temperature Range	T_{stg}	-55 to +150	$^\circ\text{C}$

Stresses exceeding Maximum Ratings may damage the device. Maximum Ratings are stress ratings only. Functional operation above the Recommended Operating Conditions is not implied. Extended exposure to stresses above the Recommended Operating Conditions may affect device reliability.

- This device series contains ESD protection and exceeds the following tests:
Human Body Model (HBM) ± 2.0 kV per JEDEC standard: JESD22-A114 for all pins except LX pin.
Human Body Model (HBM) ± 1.5 kV for LX pin.
Machine Model (MM) ± 200 V per JEDEC standard: JESD22-A115 for all pins.
- Latchup Current Maximum Rating: ± 150 mA per JEDEC standard: JESD78.
- Moisture Sensitivity Level (MSL): 1 per IPC/JEDEC standard: J-STD-020A.

NCP1403

ELECTRICAL CHARACTERISTICS ($V_{OUT} = 15\text{ V}$, $T_A = 25^\circ\text{C}$, for min/max values unless otherwise noted.)

Characteristic	Symbol	Min	Typ	Max	Unit
ON/OFF TIMING CONTROL					
Minimum Off Time ($V_{DD} = 3.0\text{ V}$, $V_{FB} = 0\text{ V}$)	t_{off}	0.8	1.3	1.5	μs
Maximum On Time (Current not asserted)	t_{on}	4.0	6.0	8.4	μs
Maximum Duty Cycle	D_{MAX}	75	83	91	%
Minimum Startup Voltage ($I_{OUT} = 0\text{ mA}$)	V_{start}	–	1.3	1.8	V
Minimum Startup Voltage Temperature Coefficient ($T_A = -40\text{ to }+85^\circ\text{C}$)	DV_{start}	–	1.6	–	$\text{mV}/^\circ\text{C}$
Minimum Supply Voltage ($I_{OUT} = 0\text{ mA}$)	V_{hold}	–	1.2	1.7	V
Soft-Start Time	t_{SS}	0.5	10	–	ms
LX (PIN 5)					
Internal Switch Voltage (Note 4)	V_{LX}	0.5	–	16	V
LX Pin On-State Sink Current ($V_{LX} = 0.4\text{ V}$, $V_{DD} = 3.0\text{ V}$)	I_{LX}	100	130	–	mA
Voltage Limit (When V_{LX} reaches V_{LXLIM} , the LX switch is turned off by the LX switch protection circuit)	V_{LXLIM}	0.55	0.75	1.0	V
Off-State Leakage Current ($V_{LX} = 16\text{ V}$)	I_{LKG}	–	0.1	1.0	μA
CE (PIN 1)					
CE Input Voltage ($V_{DD} = 3.0\text{ V}$, $V_{FB} = 0\text{ V}$)					
High State, Device Enabled	$V_{CE(high)}$	0.9	–	–	V
Low State, Device Enabled	$V_{CE(low)}$	–	–	0.3	V
CE Input Current					
High State, Device Enabled ($V_{DD} = V_{CE} = 5.5\text{ V}$)	$I_{CE(high)}$	–0.5	0	0.5	μA
Low State, Device Enabled ($V_{DD} = 5.5\text{ V}$, $V_{CE} = V_{FB} = 0\text{ V}$)	$I_{CE(low)}$	–0.5	–0.1	0.5	μA
TOTAL DEVICE					
Supply Voltage	V_{DD}	1.2	–	5.5	V
Feedback Voltage	V_{FB}	0.76	0.8	0.84	V
Feedback Pin Bias Current ($V_{FB} = 0.8\text{ V}$)	I_{FB}	–	15	30	nA
Operating Current 1 ($V_{FB} = 0\text{ V}$, $V_{DD} = V_{CE} = 3.0\text{ V}$)	I_{DD1}	–	130	200	μA
Operating Current 2 ($V_{DD} = V_{CE} = V_{FB} = 3.0\text{ V}$, Not switching)	I_{DD2}	–	19	25	μA
Off-state Current ($V_{DD} = 5.0\text{ V}$, $V_{CE} = 0\text{ V}$, internal 100 nA pullup current source)	I_{OFF}	–	0.3	0.8	μA

4. Recommend maximum V_{OUT} up to 15 V.

TYPICAL CHARACTERISTICS

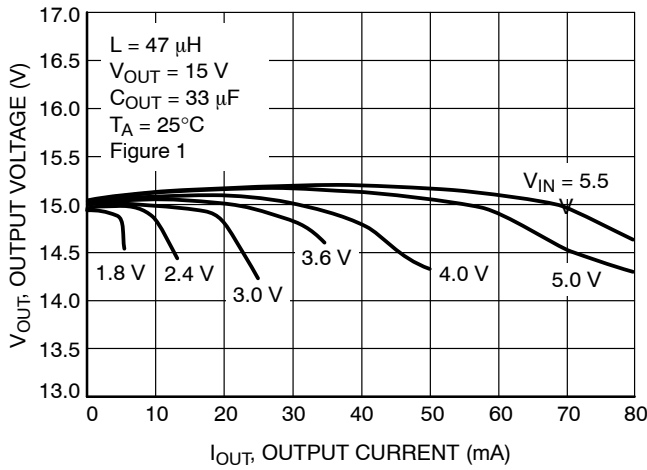

Figure 4. Output Voltage versus Output Current ($V_{\text{OUT}} = 15 \text{ V}$)

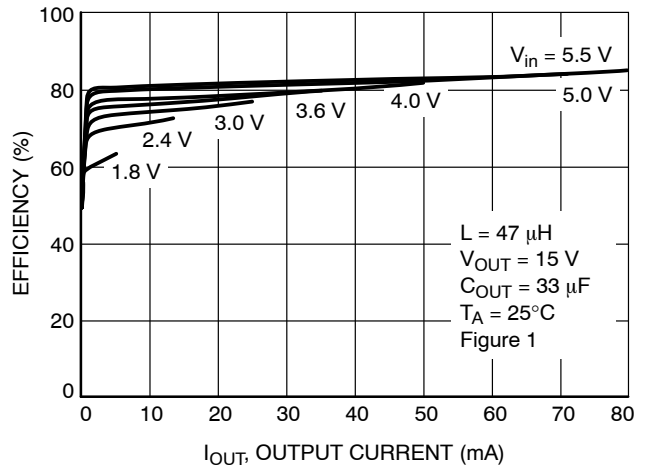

Figure 5. Efficiency versus Output Current ($V_{\text{OUT}} = 15 \text{ V}$)

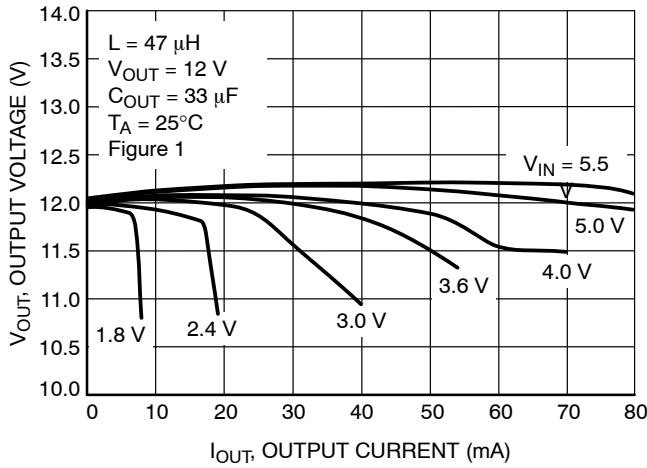

Figure 6. Output Voltage versus Output Current ($V_{\text{OUT}} = 12 \text{ V}$)

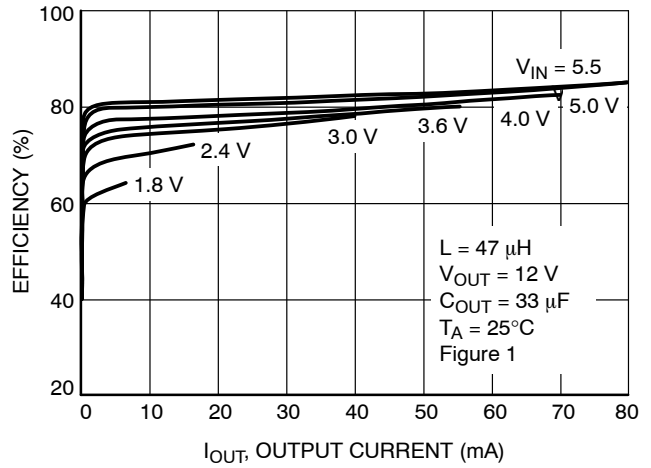

Figure 7. Efficiency versus Output Current ($V_{\text{OUT}} = 12 \text{ V}$)

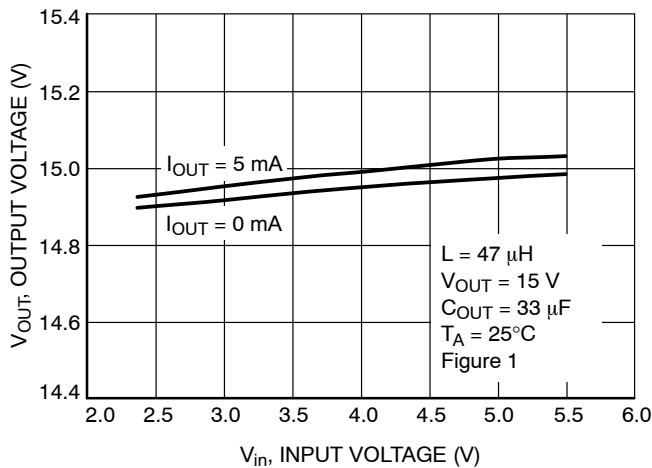

Figure 8. Output Voltage versus Input Voltage ($V_{\text{OUT}} = 15 \text{ V}$)

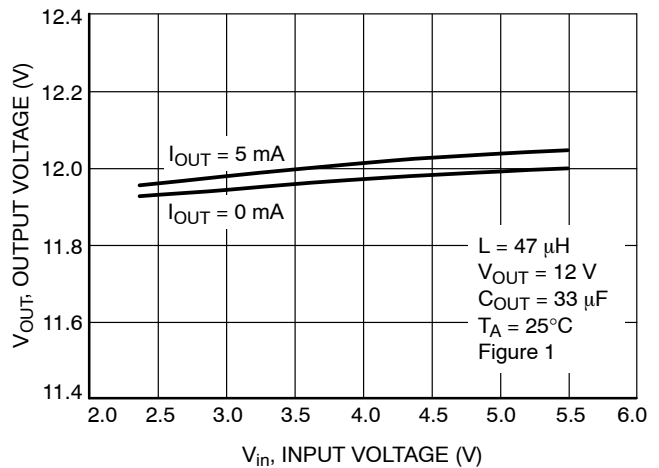

Figure 9. Output Voltage versus Input Voltage ($V_{\text{OUT}} = 12 \text{ V}$)

TYPICAL CHARACTERISTICS

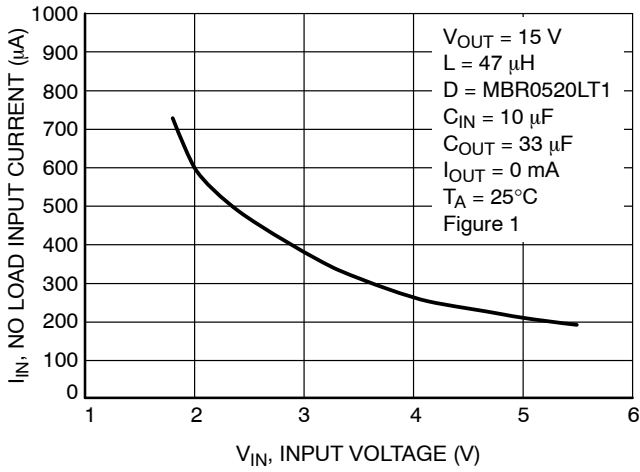

Figure 10. No Load Input Current versus Input Voltage

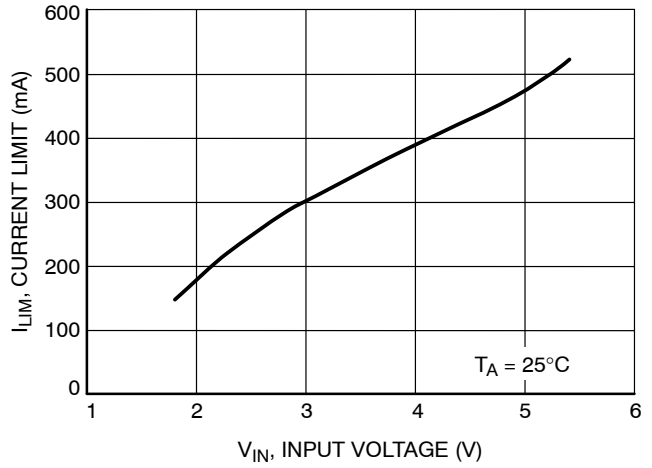

Figure 11. Current Limit versus Input Voltage

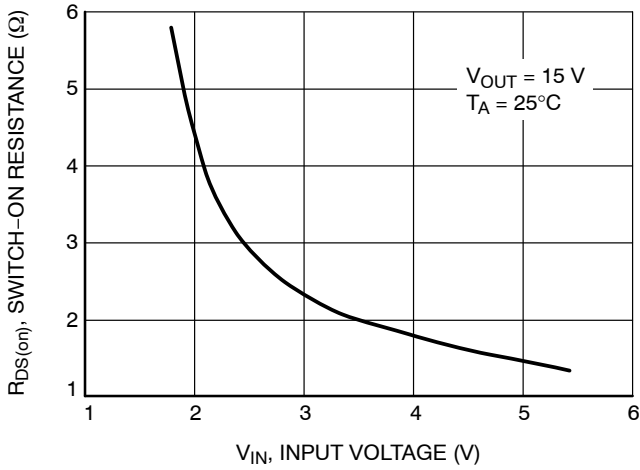

Figure 12. Switch-On Resistance versus Input Voltage

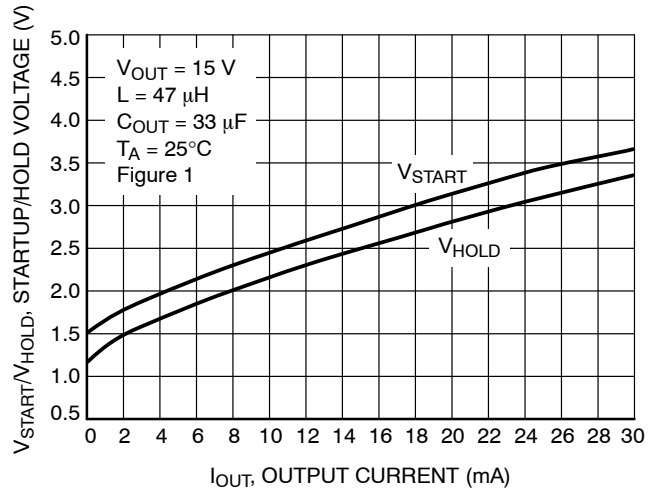

Figure 13. Startup/Hold Voltage versus Output Current

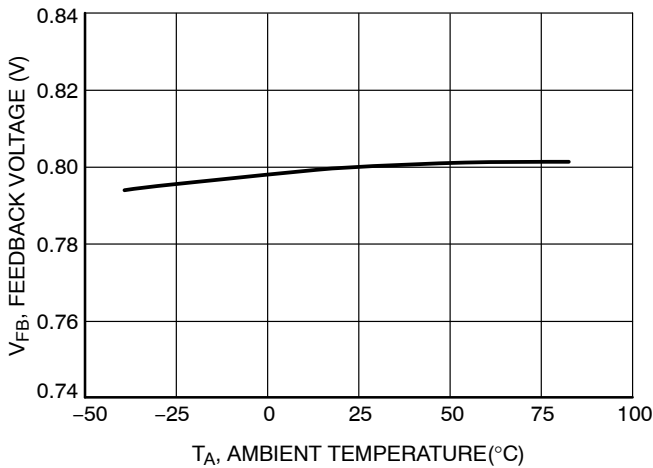

Figure 14. Feedback Voltage versus Ambient Temperature

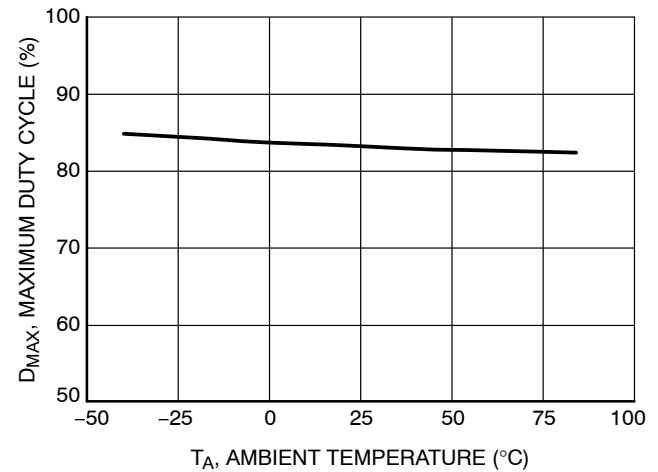

Figure 15. Maximum Duty Cycle versus Ambient Temperature

NCP1403

TYPICAL CHARACTERISTICS

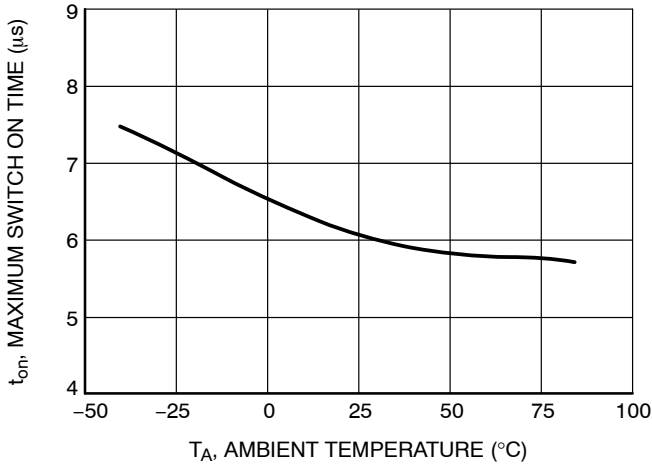

Figure 16. Maximum Switch On Time

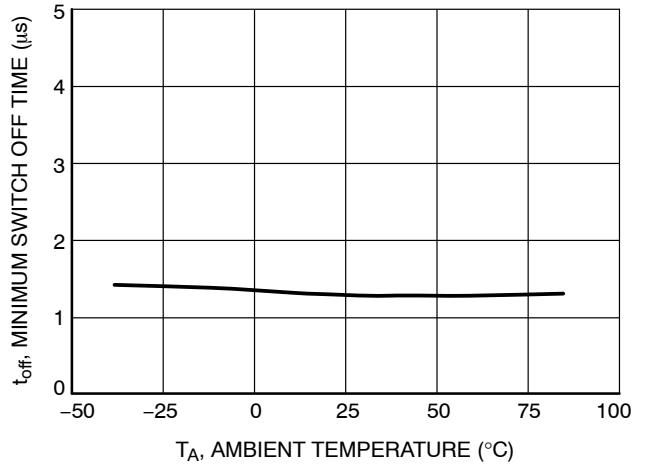

Figure 17. Minimum Switch Off Time

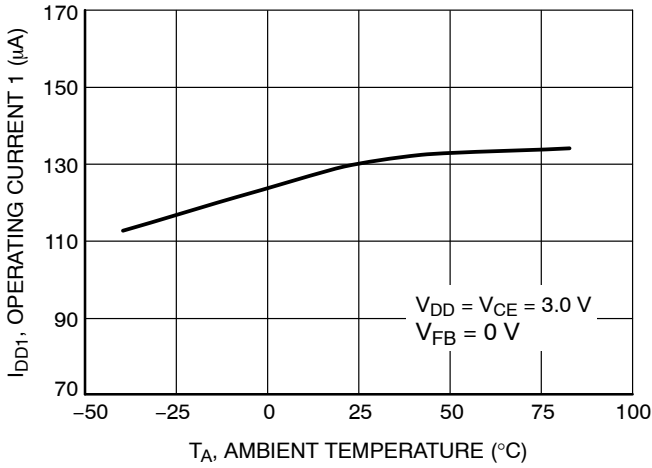

Figure 18. Operating Current 1 versus Ambient Temperature

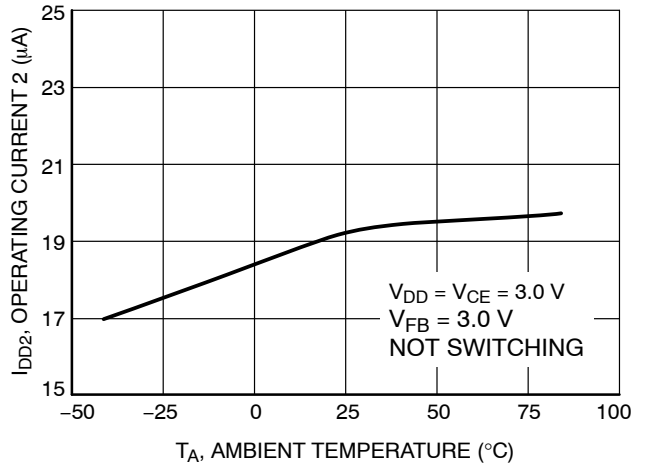

Figure 19. Operating Current 2 versus Ambient Temperature

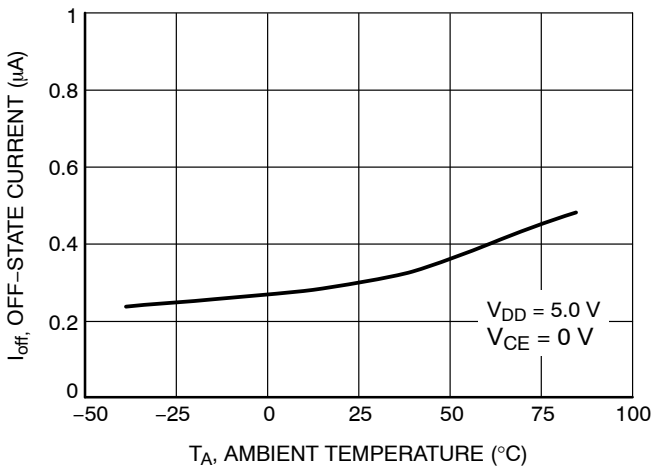

Figure 20. Off-State Current versus Ambient Temperature

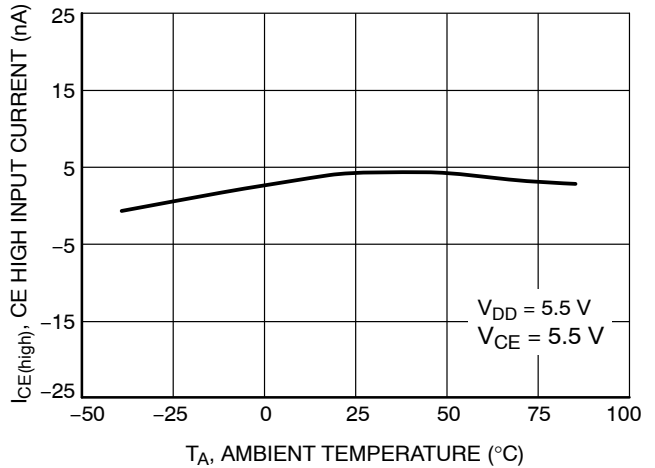
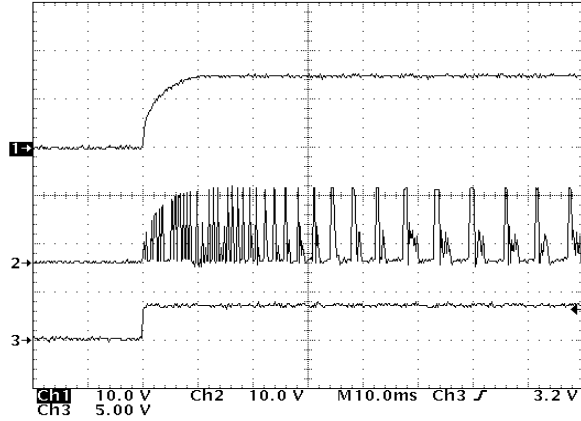

Figure 21. CE High Input Current versus Ambient Temperature

TYPICAL CHARACTERISTICS



$L = 47 \mu\text{H}$, $C_{\text{IN}} = 10 \mu\text{F}$, $C_{\text{OUT}} = 33 \mu\text{F}$, $I_{\text{OUT}} = 20 \text{ mA}$
 1. $V_{\text{OUT}} = 15 \text{ V}$, 10 V/div
 2. V_{LX} , 10 V/div
 3. $V_{\text{IN}} = 0 \text{ V}$ to 3.6 V, 5 V/div

Figure 22. Startup Waveforms

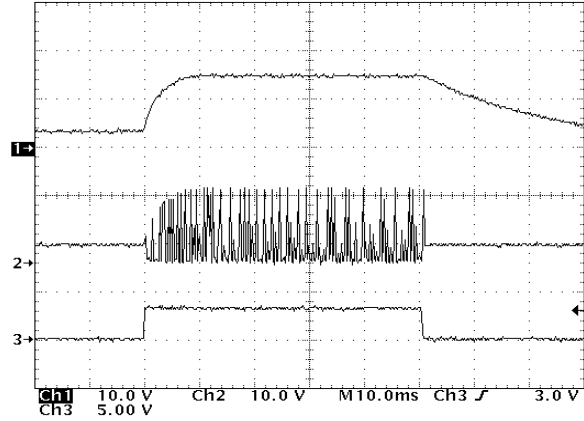

$L = 47 \mu\text{H}$, $C_{\text{IN}} = 10 \mu\text{F}$, $C_{\text{OUT}} = 33 \mu\text{F}$, $V_{\text{IN}} = 3.6 \text{ V}$, $I_{\text{OUT}} = 20 \text{ mA}$
 1. $V_{\text{OUT}} = 15 \text{ V}$, 10 V/div
 2. V_{LX} , 10 V/div
 3. $V_{\text{CE}} = 0 \text{ V}$ to 3.6 V, 5 V/div

Figure 23. Chip Enable Waveforms

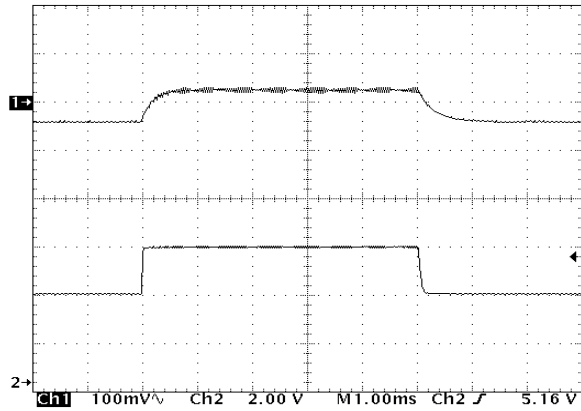

$L = 47 \mu\text{H}$, $C_{\text{IN}} = 10 \mu\text{F}$, $C_{\text{OUT}} = 33 \mu\text{F}$, $I_{\text{OUT}} = 10 \text{ mA}$
 1. $V_{\text{OUT}} = 15 \text{ V}$ (AC Coupled), 100 mV/div
 2. $V_{\text{IN}} = 3.6 \text{ V}$ to 5.5 V, 2.0 V/div

Figure 24. Line Transient Response

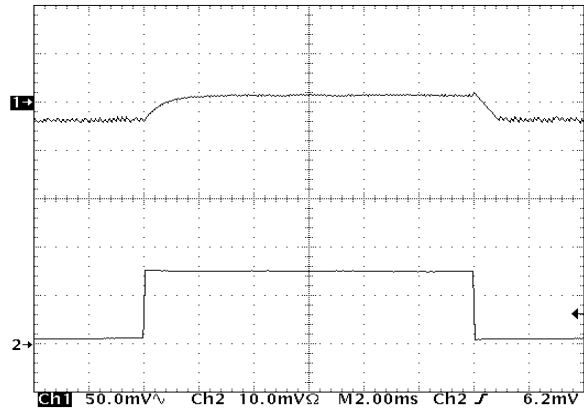

$L = 47 \mu\text{H}$, $C_{\text{IN}} = 10 \mu\text{F}$, $C_{\text{OUT}} = 33 \mu\text{F}$, $V_{\text{IN}} = 3.6 \text{ V}$
 1. $V_{\text{OUT}} = 15 \text{ V}$ (AC Coupled), 50 mV/div
 2. $I_{\text{OUT}} = 1.0 \text{ mA}$ to 15 mA, 10 mA/div

Figure 25. Load Transient Response

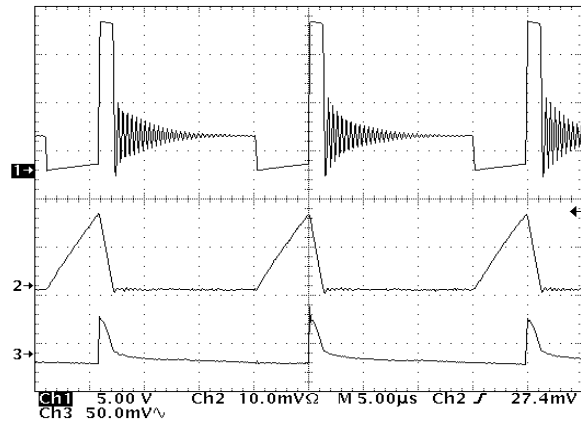

$L = 47 \mu\text{H}$, $C_{\text{IN}} = 10 \mu\text{F}$, $C_{\text{OUT}} = 33 \mu\text{F}$, $V_{\text{IN}} = 3.6 \text{ V}$, $V_{\text{OUT}} = 15 \text{ V}$, $I_{\text{OUT}} = 10 \text{ mA}$
 1. V_{LX} , 5.0 V/div
 2. I_{L} , 200 mA/div
 3. V_{ripple} , 50 mV/div

Figure 26. Operating Waveforms (Medium Load)

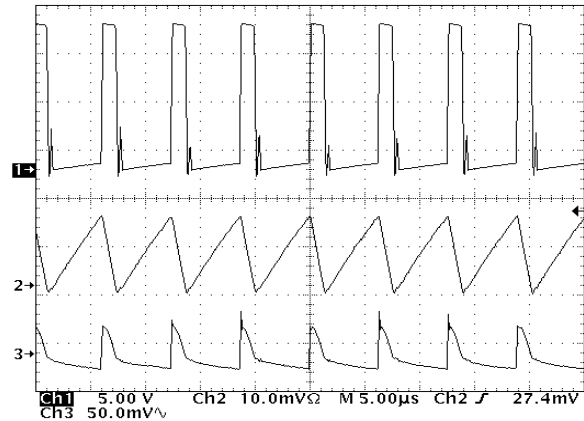

$L = 47 \mu\text{H}$, $C_{\text{IN}} = 10 \mu\text{F}$, $C_{\text{OUT}} = 33 \mu\text{F}$, $V_{\text{IN}} = 3.6 \text{ V}$, $V_{\text{OUT}} = 15 \text{ V}$, $I_{\text{OUT}} = 30 \text{ mA}$
 1. V_{LX} , 5.0 V/div
 2. I_{L} , 200 mA/div
 3. V_{ripple} , 50 mV/div

Figure 27. Operating Waveforms (Heavy Load)

DETAILED OPERATING DESCRIPTION

Operation

The NCP1403 is monolithic DC–DC switching converter optimized for single Lithium or two cells AA/AAA size batteries powered portable products.

The NCP1403 device consists of startup circuit, chip enable circuit, PFM comparator, voltage reference, PFM on/off timing control circuit, driver, current limit circuit, and open–drain MOSFET switch. The device operating current is typically 130 μA , and can be further reduced to about 0.3 μA when the chip is disabled ($V_{\text{CE}} < 0.3 \text{ V}$).

The operation of NCP1403 can be best understood by referring to the block diagram and typical application circuit 1 in Figures 3 and 1. The PFM comparator monitors the output voltage via the external feedback resistor divider by comparing the feedback voltage with the reference voltage. When the feedback voltage is lower than the reference voltage, the PFM control and driver circuit turns on the N–Channel MOSFET switch and the current ramps up in the inductor. The switch will remain on for the maximum on–time, 6.0 μs , or until the current limit is reached, whichever occurs first. The MOSFET switch is then turned off and energy stored in the inductor will be discharged to the output capacitor and load through the Schottky diode. The MOSFET switch will be turned off for at least the minimum off–time, 1.3 μs , and will remain off if the feedback voltage is higher than the reference voltage and output capacitor will be discharged to sustain the output current, until the feedback voltage is again lower than reference voltage. This switching cycle is then repeated to attain voltage regulation.

Soft Start

There is a soft start circuit in NCP1403. When power is applied to the device, the soft start circuit pumps up the output voltage to approximately 1.5 V at a fixed duty cycle, the level at which the converter can operate normally. With the soft start circuit, the output voltage overshoot is minimized and the startup capability with heavy loads is also improved.

ON/OFF Timing Control

The maximum on–time is typically 6.0 μs , whereas, the minimum off–time is typically 1.3 μs . Owing to the current limit circuit, the on–time can be shorter. The switching frequency can be up to 300 kHz.

Voltage Reference and Output Voltage

The internal voltage reference is trimmed to 0.8 V at an accuracy of $\pm 5.0\%$. The voltage reference is connected to the non–inverting input of the PFM comparator and the inverting input of the PFM comparator is connected to the FB pin. The output voltage can be set by connected an external resistor voltage divider from the V_{OUT} to the FB pin. With the internal 16 V MOSFET switch, the output voltage can be set between V_{IN} to 15 V.

LX Limit

The LX Limit is a current limit feature which is achieved by monitoring the voltage at the LX pin during the MOSFET switch turn–on period. When the switch is turned on, current ramps up in the inductor, and the voltage at the LX pin will increase according to the Ohm’s Law due to the On–state resistance of the MOSFET. When the VLX is greater than 0.75 V, the switch will be turned off. With the current limit circuit, saturation of inductor is prevented and output voltage overshoot during startup can also be minimized.

N–Channel MOSFET Switch

The NCP1403 is built–in with a 16 V open drain N–Channel MOSFET switch which allows high output voltage up to 15 V to be generated from simple step–up topology.

Enable / Disable Operation

The NCP1403 offers IC shut–down mode by the chip enable pin (CE pin) to reduce current consumption. An internal 100 nA pullup current source tied the CE pin to OUT pin by default i.e. user can float the pin CE for permanent “ON”. When voltage at pin CE is equal to or greater than 0.9 V, the chip will be enabled, which means the device is in normal operation. When voltage at pin CE is less than 0.3 V, the chip is disabled, which means IC is shutdown. During shutdown, the IC supply current reduces to 0.3 μA and LX pin enters high impedance state. However, the input remains connected to the output through the inductor and the Schottky diode, keeping the output voltage to one diode forward voltage drop below the input voltage.

APPLICATIONS CIRCUIT INFORMATION

External Component Selection
Inductor

The NCP1403 is designed to work well with a range of inductance values, the actual inductance value depends on the specific application, output current, efficiency, and output ripple voltage. For step up conversion, the device works well with inductance ranging from 22 μH to 47 μH. Inductor with small DCR, usually less than 1.0 Ω, should be used to minimize loss. It is necessary to choose an inductor with saturation current greater than the peak switching current in the application.

If 22 μH inductance is used, lower profile surface mount inductor can be selected for the same current rating. Moreover, it permits the converter to switch at higher frequency up to 300 kHz since the inductor current will ramp up faster and hit the current limit at a shorter time for smaller inductance value. However, current output are slightly lower because the off-time is limited by the minimum off-time. If 47 μH inductance is selected, higher efficiency and output current capability are achieved, but the converter will switch at a lower frequency and the inductor size will be slightly larger for the same current rating.

For lower inductance value, the inductor current ramp-down time will be shorter than the minimum off-time. Consequently, the converter can only operate in discontinuous conduction mode and lower output current can be generated. For higher inductance value, if the inductance is sufficiently large, the maximum on-time will expire before the current limit is reached. As a result, the available output power and output current are reduced. Besides, instability may occur when operation enters CCM.

To ensure the current limit is reached before the maximum on-time expires, L can be selected according to the inequality below:

$$L \leq \frac{(V_{IN} - V_S)}{I_{LIM}} \cdot t_{on(MAX)}$$

where $V_S = 0.75$ V which is the MOSFET saturation voltage, and I_{LIM} is the current limit which can be referred to in Figure 11, and $t_{on(MAX)} = 6.0$ μs.

If the above condition is satisfied, $I_{PK} = I_{LIM}$; where I_{PK} is the peak inductor current. Then, step-up converter with inductor satisfy the following condition will operate in DCM only,

$$\frac{I_{LIM} \cdot L}{(V_{OUT} + V_D - V_{IN})} \leq t_{off(MIN)}$$

If the $I_{PK} = I_{LIM}$, step-up converter with inductor satisfy the following condition will operate in CCM at maximum output current,

$$\frac{I_{LIM} \cdot L}{(V_{OUT} + V_D - V_{IN})} > t_{off(MIN)}$$

where V_D is the Schottky diode forward voltage drop, $t_{off(MIN)} = 1.3$ μs.

For step-up converter operates in DCM only, the maximum output current can be calculated from the equation below:

$$I_{OUT(MAX)} = \frac{(I_{LIM})^2 L}{2(V_{OUT} + V_D - V_{IN}) \left(\frac{I_{LIM} \times L}{(V_{IN} - V_S)} + t_{off(MIN)} \right)}$$

For step-up converter operates in CCM, the maximum output current can be calculated from the equation below:

$$I_{OUT(MAX)} = \left(I_{LIM} - \frac{(V_{OUT} + V_D - V_{IN}) t_{off(MIN)}}{2L} \right) \cdot \frac{(V_{IN} - V_S)}{(V_{OUT} + V_D - V_S)}$$

Diode

The diode is the main source of loss in DC-DC converters. The most importance parameters which affect their efficiency are the forward voltage drop, V_F , and the reverse recovery time, t_{rr} . The forward voltage drop creates a loss just by having a voltage across the device while a current flowing through it. The reverse recovery time generates a loss when the diode is reverse biased, and the current appears to actually flow backwards through the diode due to the minority carriers being swept from the P-N junction. A Schottky diode with the following characteristics is recommended:

1. Small forward voltage, $V_F < 0.3$ V
2. Small reverse leakage current
3. Fast reverse recovery time / switching speed
4. Rated current larger than peak inductor current,
 $I_{rated} > I_{PK}$
5. Reverse voltage larger than output voltage,
 $V_{reverse} > V_{OUT}$

Input Capacitor

The input capacitor can stabilize the input voltage and minimize peak current ripple from the source. The value of the capacitor depends on the impedance of the input source used. Small ESR (Equivalent Series Resistance) Tantalum or ceramic capacitor with value of 10 μF should be suitable.

Output Capacitor

The output capacitor is used for sustaining the output voltage when no current is delivering from the input, and smoothing the ripple voltage. Low ESR Tantalum capacitor should be used to reduce output ripple voltage since the output ripple voltage is dominated by the ESR value of the Tantalum capacitor. In general, a 22 μF to 47 μF low ESR (0.2 Ω to 0.4 Ω) Tantalum capacitor should be appropriate. The output ripple voltage can be approximately given by the following equation:

$$V_{ripple} \approx (I_{PK} - I_{OUT}) \cdot ESR$$

Feedback Resistors

Choose the RFB2 value from the range 10 kΩ to 200 kΩ for positive output voltage. The value of RFB1 can then be calculated from the equation below:

$$R_{FB1} = R_{FB2} \left(\frac{V_{OUT}}{0.8} - 1 \right)$$

NCP1403

1% tolerance resistors should be used for both R_{FB1} and R_{FB2} for better V_{OUT} accuracy.

Output Voltage Higher than 15 V

NCP1403 can be used to generate output voltage higher than 15 V by adding an external high voltage N-Channel MOSFET in series with the internal MOSFET switch as shown in Figure 33. The drain-to-source breakdown voltage of the external MOSFET must be at least 1 V higher than the output voltage. The diode D1 helps the external MOSFET to turn off and ensures that most of the voltage across the external MOSFET during the switch-off period. Since the high voltage external MOSFET is in series with the internal MOSFET, higher break down voltage is achieved but the current capability is not increased.

There is an alternative application circuit shown in Figure 35 which can output voltage up to 30 V. For this circuit, a diode-capacitor charge-pump voltage doubler constructed by D2, D3 and C1 is added. During the internal MOSFET switch-on time, the LX pin is shorted to ground and D2 will charge up C1 to the stepped up voltage at the cathode of D1. During the MOSFET switch-off time, the voltage at V_{OUT} will be almost equal to the double of the voltage at the cathode of D1. The V_{OUT} is monitored by the FB pin via the resistor divider and can be set by the resistor values. Since the maximum voltage at the cathode of D1 is 15 V, the maximum V_{OUT} is 30 V. The value of C1 can be in the range of 0.47 μF to 2.2 μF.

Negative Voltage Generation

The NCP1403 can be used to produce a negative voltage output by adding a diode-capacitor charge-pump circuit (D2, D3, and C1) to the LX pin as shown in Figure 32. The feedback voltage resistor divider is still connected to the positive output to monitor the positive output voltage and a small value capacitor is used at C2. When the internal MOSFET switches off, the voltage at the LX pin charges up the capacitor through diode D2. When the MOSFET switches on, the capacitor C1 is effectively connected like a reversed battery and C1 discharges the stored charges through the R_{ds(on)} of the internal MOSFET and D3 to charge up C_{OUT} and builds up a negative voltage at V_{OUT}. Since the negative voltage output is not directly monitored by the NCP1403, the output load regulation of the negative output is not as good as the standard positive output circuit. The resistance values of the resistors of the voltage divider can be one-tenth of those used in the positive output circuit in order to improve the regulation at light load.

For the application circuit in Figure 36, it is actually the combination of the application circuits in Figures 32 and 33.

Step-Down Converter

NCP1403 can be configured as a simple step-down converter by using the open-drain LX pin to drive an external P-Channel MOSFET as shown in Figure 34. The resistor R_{GS} is used to switch off the P-Channel MOSFET during the switch-off period. Too small resistance value should not be used for R_{GS}, otherwise, the efficiency will be reduced.

White LED Driver

The NCP1403 can be used as a constant current LED driver which can drive up to 4 white LEDs in series as shown in Figure 2. The LED current can be set by the resistance value of R_S. The desired LED current can be calculated by the equation below:

$$I_{LED} = \frac{0.8}{R_S}$$

Moreover, the brightness of the LEDs can be adjusted by a DC voltage or a PWM signal with an additional circuit illustrated below:

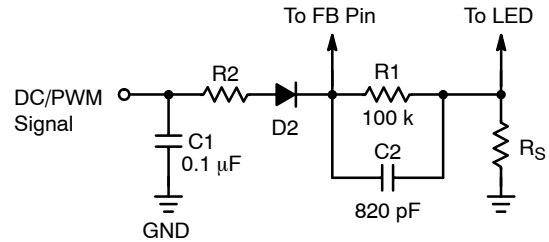

With this additional circuit, the maximum LED current is set by the above equation. The value of R₂ can be obtained by the following equation:

$$R_2 = \frac{V_{MAX} - V_D - 0.8}{\left(\frac{I_{LED(MAX)} - I_{LED(MIN)}}{R_1}\right) R_S}$$

V_{MAX} is the maximum voltage of the control signal, V_D is the diode forward voltage, I_{LED(MAX)} is the maximum LED current and I_{LED(MIN)} is the minimum LED current. If a PWM control signal is used, the signal frequency from 4 kHz to 40 kHz can be applied.

In case the LEDs fail, the feedback voltage will become zero. The NCP1403 will then switch at maximum duty cycle and result in a high output voltage which will cause the LX pin voltage to exceed its maximum rating. A Zener diode can be added across the output and FB pin to limit the voltage at the LX pin. The Zener voltage should be higher than the total forward voltage of the LED string.

PCB Layout Hints

The schematic, PCB trace layout, and component placement of the step-up DC-DC converter demonstration board are shown in Figure 28 to Figure 31 for PCB layout design reference.

Grounding

One point grounding should be used for the output power return ground, the input power return ground, and the device switch ground to reduce noise. The input ground and output ground traces must be thick and short enough for current to flow through. A ground plane should be used to reduce ground bounce.

NCP1403

Power Signal Traces

Low resistance conducting paths should be used for the power carrying traces to reduce power loss so as to improve efficiency (short and thick traces for connecting the inductor L can also reduce stray inductance). Besides, the length and area of all the traces with connection to the LX pin should be minimized. e.g., short and thick traces listed below should be used in the PCB:

1. Trace from V_{IN} to L
2. Trace from L to LX pin of the IC
3. Trace from L to anode pin of Schottky diode
4. Trace from cathode pin of Schottky diode to V_{OUT} .

External Feedback Resistors

Feedback resistors should be located as close to the FB pin as possible to minimize noise picked up by the FB pin. The ground connection of the feedback resistor divider should be connected directly to the GND pin.

Input Capacitor

The input capacitor should be located close to both the V_{IN} to the inductor and the V_{DD} pin of the IC.

Output Capacitor

The output capacitor should be placed close to the output terminals to obtain better smoothing effect on output ripple voltage.

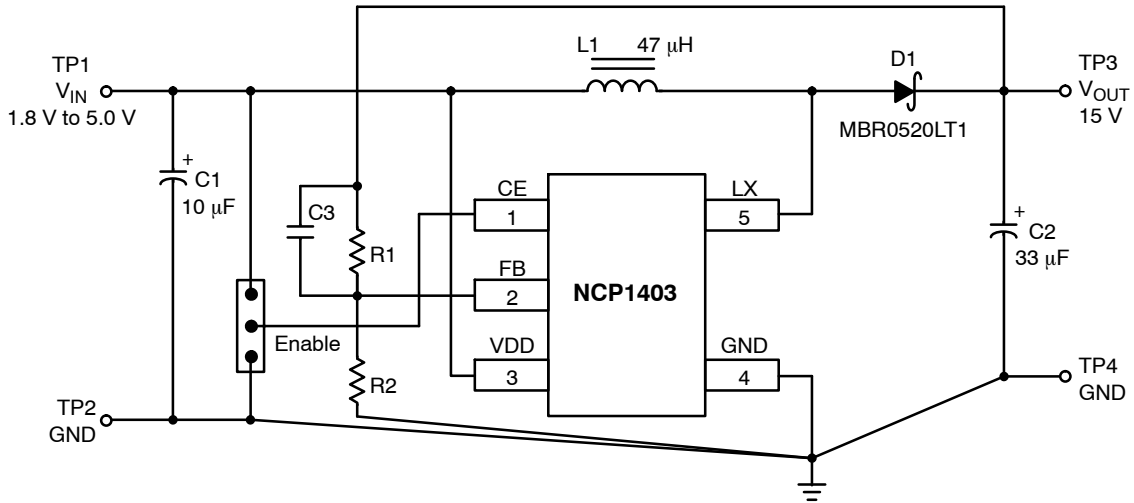

Figure 28. Step-Up Converter Demonstration Board Schematic

NCP1403

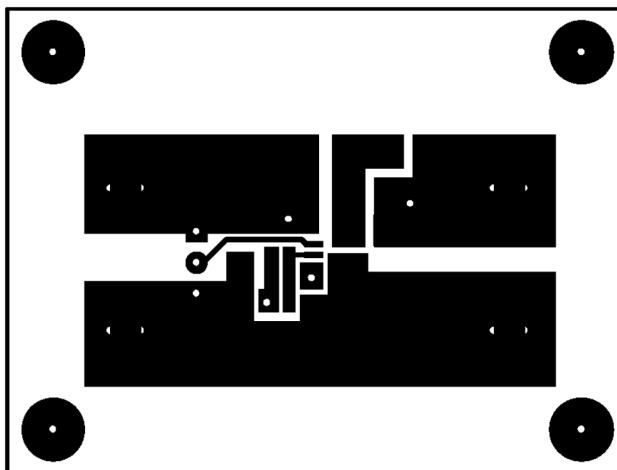

Figure 29. Step-Up Converter Demonstration Board Top Layer Copper

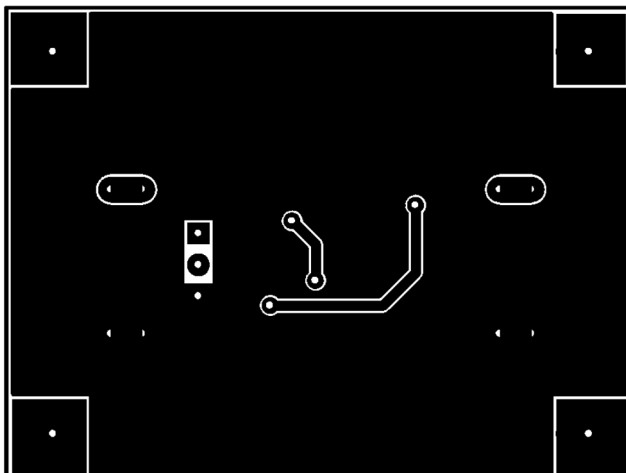

Figure 30. Step-Up Converter Demonstration Board Bottom Layer Copper

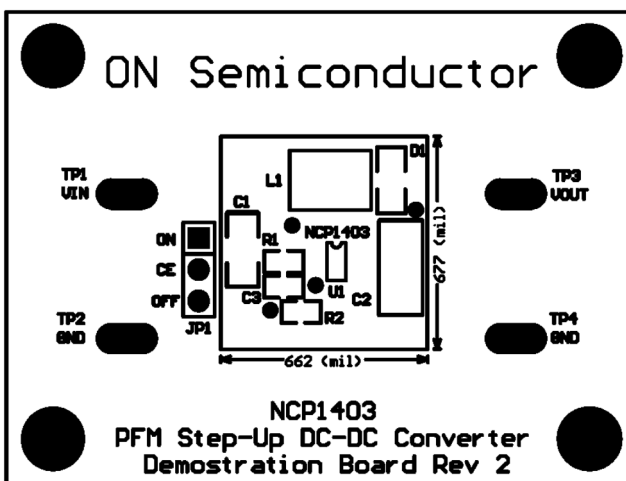

Figure 31. Step-Up Converter Demonstration Board Top Layer Component Silkscreen

NCP1403

Components Supplier

Parts	Supplier	Part Number	Description	Phone
L1	Sumida Electric Co. Ltd.	CD43-470KC	Inductor 47 μ H	(852) 2880-6688
D1	ON Semiconductor	MBR0520LT1	Schottky Power Rectifier	(852) 2689-0088
C1	Kemet Electronics Corp.	T494A106K010AS	Low ESR Tantalum Capacitor 10 μ F/10 V	(852) 2305-1168
C2	Kemet Electronics Corp.	T494C336K016AS	Low ESR Tantalum Capacitor 33 μ F/16 V	(852) 2305-1168

OTHER APPLICATIONS

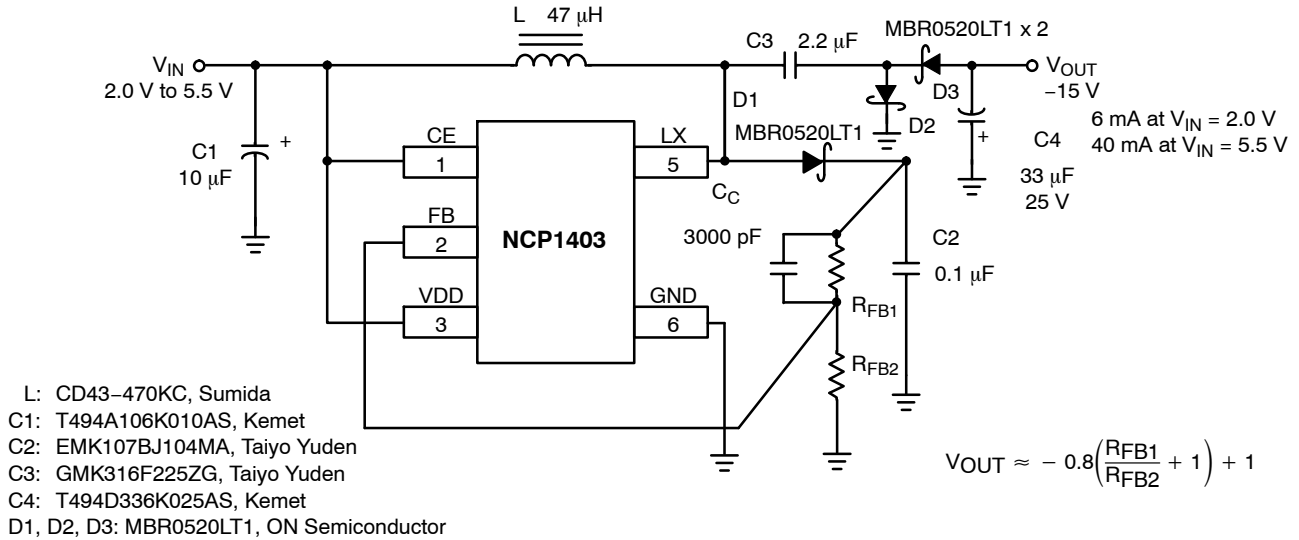

Figure 32. Positive-to-Negative Output Converter for Negative LCD Bias

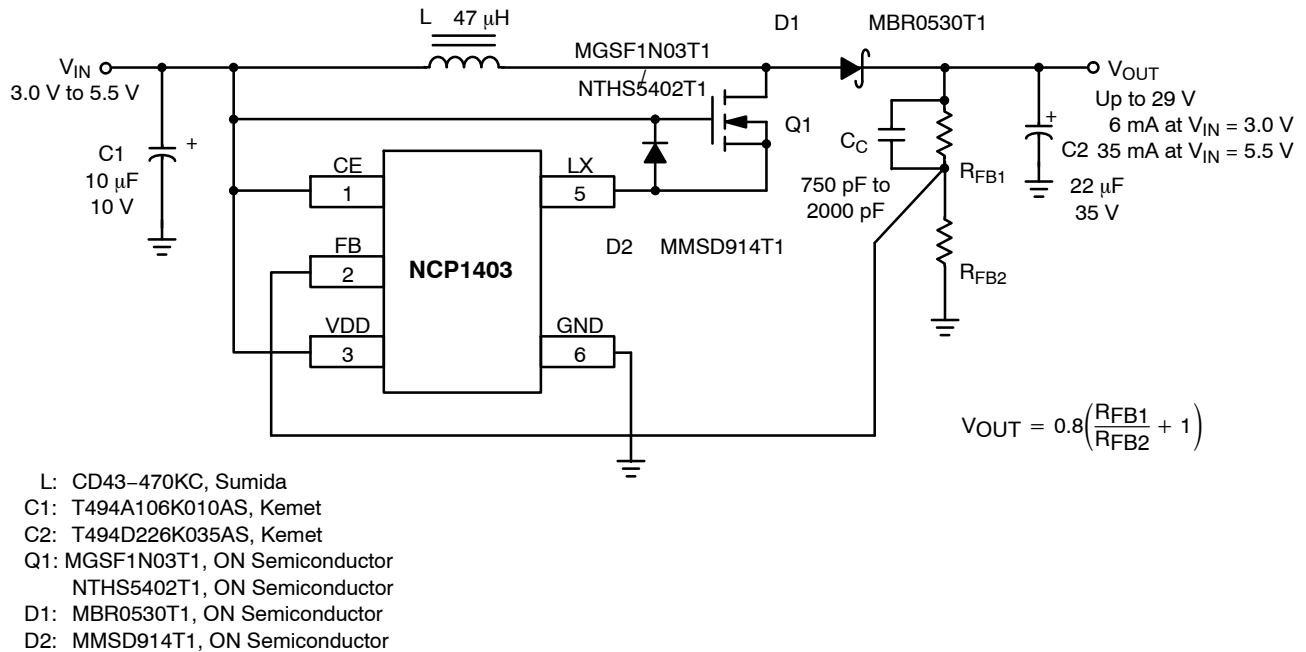

Figure 33. Step-Up DC-DC Converter with 29 V Output Voltage

NCP1403

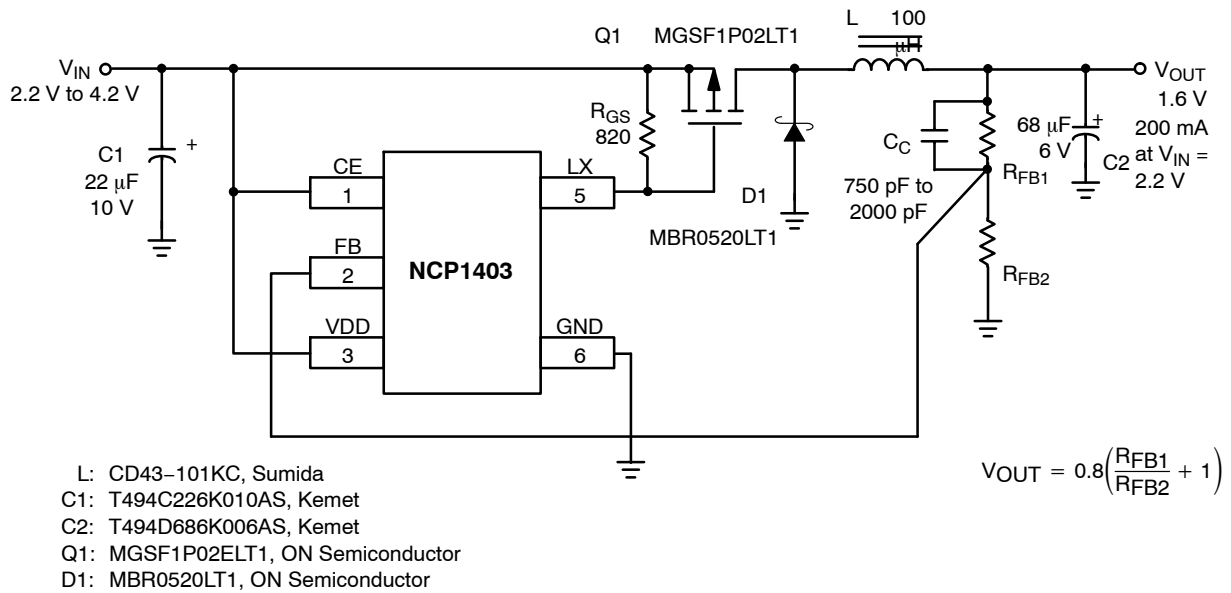

Figure 34. Step-down DC-DC Converter with 1.6 V Output Voltage for DSP Circuit

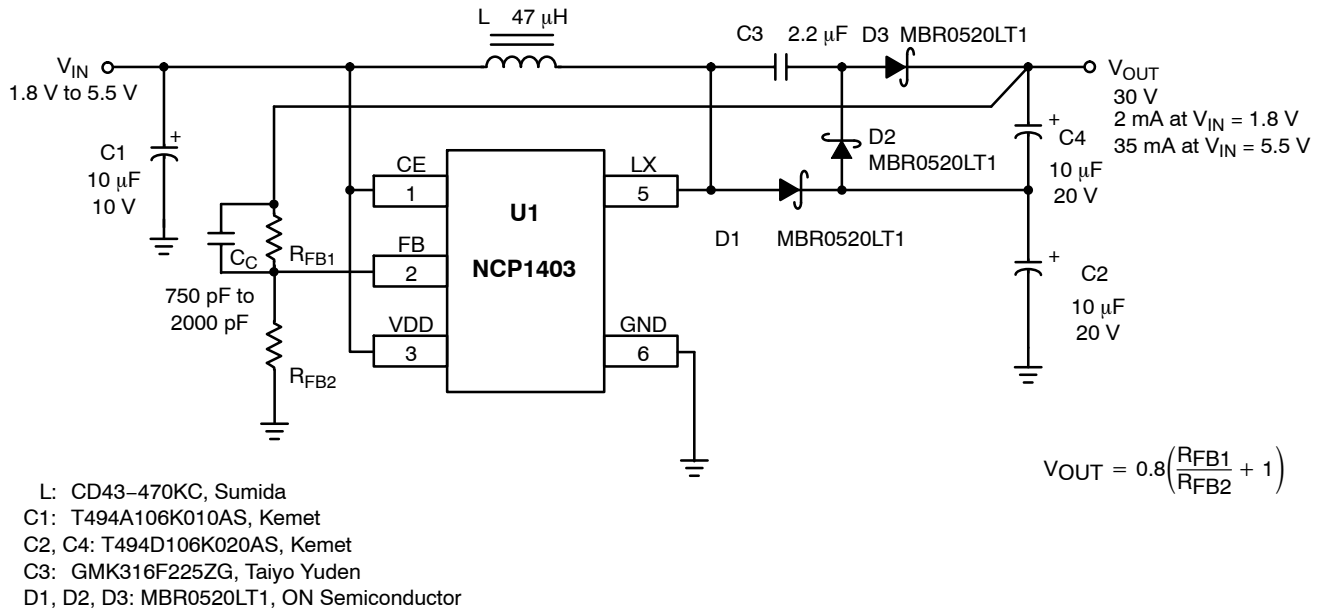
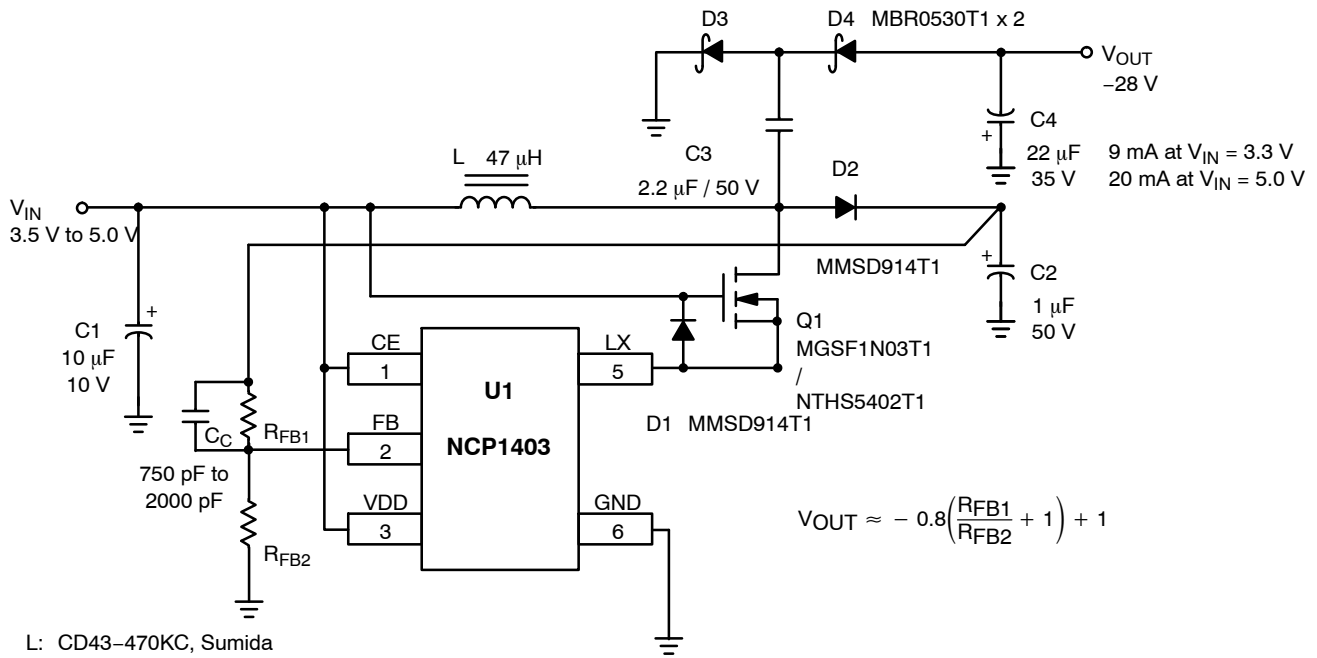

Figure 35. Step-Up DC-DC Converter with 30 V Output Voltage

NCP1403



- L: CD43-470KC, Sumida
- C1: T494A106K010AS, Kemet
- C2: UMK212F105ZG, Taiyo Yuden
- C3: GMK316F225ZG, Taiyo Yuden
- C4: T494D226K035AS, Kemet
- Q1: MGSF1N03T1, ON Semiconductor/
NTHS5402T1, ON Semiconductor
- D1, D2: MMSD914T1, ON Semiconductor
- D3, D4: MBR0530T1, ON Semiconductor

Figure 36. Voltage Inverting DC-DC Converter with -28 V Output Voltage

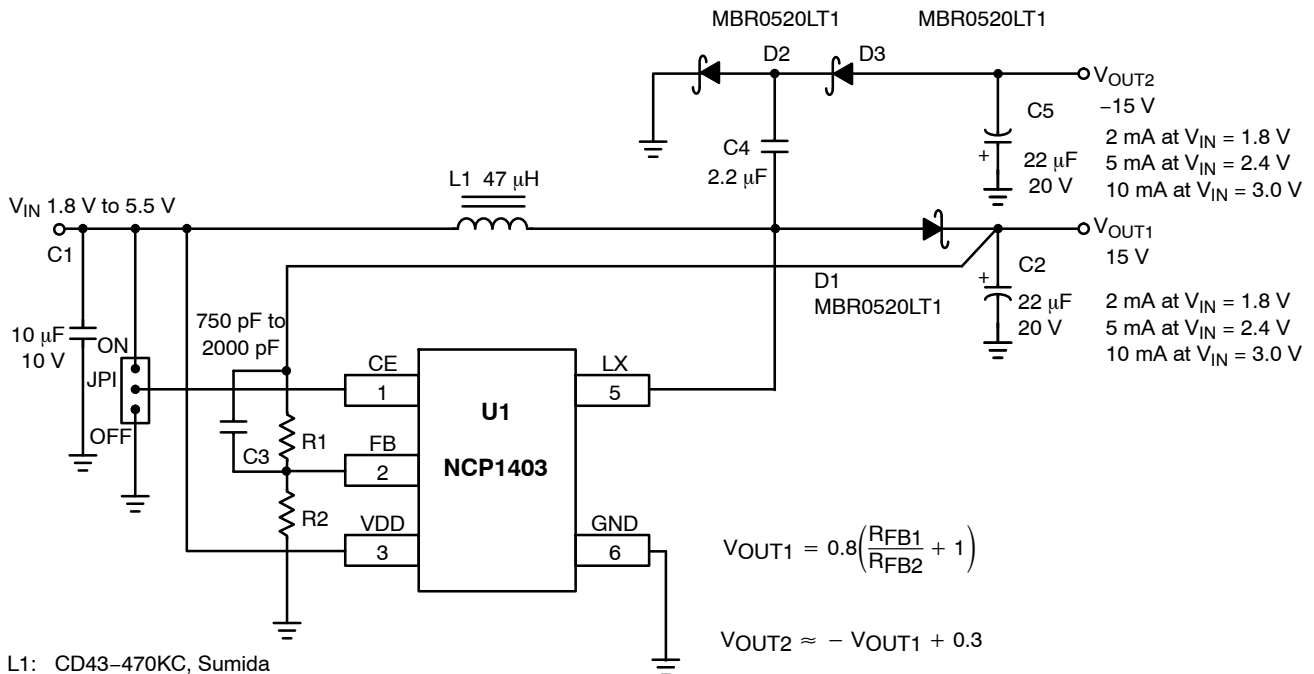

- L1: CD43-470KC, Sumida
- C1: T494A106K010AS, Kemet
- C2, C5: T494C226K020AS, Kemet
- C3: UMK107B102KZ, Taiyo Yuden
- C4: TMK316BJ225ML, Taiyo Yuden
- D1, D2, D3: MBR0520LT1, ON Semiconductor
- R1: 390 kΩ
- R2: 22 kΩ

Figure 37. +15 V, -15 V Outputs Converter for LCD Bias Supply

NCP1403

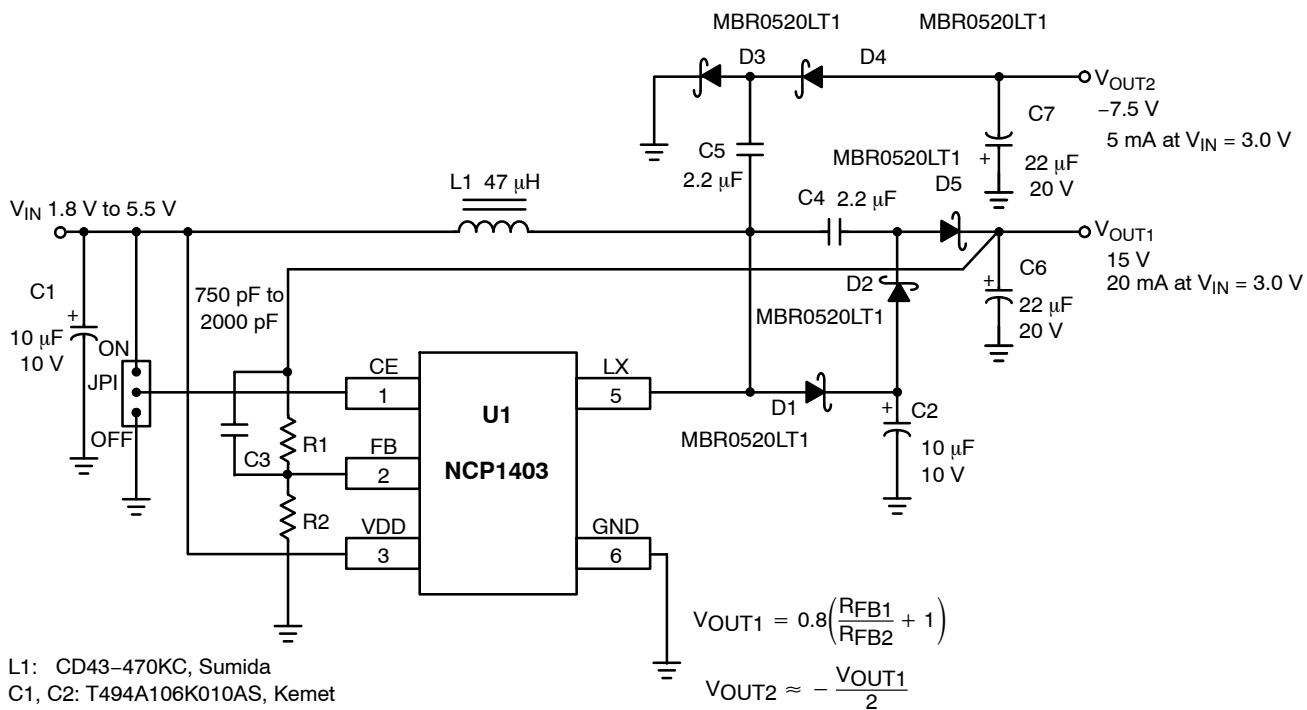

- L1: CD43-470KC, Sumida
- C1, C2: T494A106K010AS, Kemet
- C3: UMK107B102KZ, Taiyo Yuden
- C4, C5: TMK316BJ225ML, Taiyo Yuden
- C6, C7: T494C226K020AS, Kemet
- D1, D2, D3, D4, D5: MBR0520LT1, ON Semiconductor
- R1: 390 kΩ
- R2: 22 kΩ

Figure 38. +15 V, -7.5 V Outputs Converter for CCD Supply Circuit

MECHANICAL CASE OUTLINE PACKAGE DIMENSIONS

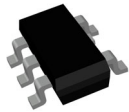

TSOP-5 3.00x1.50x0.95, 0.95P CASE 483 ISSUE P

DATE 01 APR 2024

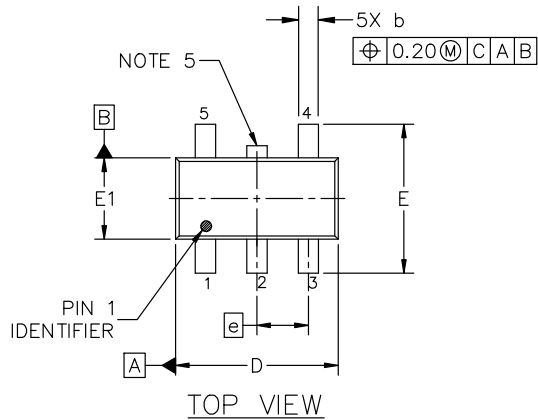

NOTES:

1. DIMENSIONING AND TOLERANCING CONFORM TO ASME Y14.5-2018.
2. ALL DIMENSION ARE IN MILLIMETERS (ANGLES IN DEGREES).
3. MAXIMUM LEAD THICKNESS INCLUDES LEAD FINISH THICKNESS. MINIMUM LEAD THICKNESS IS THE MINIMUM THICKNESS OF BASE MATERIAL.
4. DIMENSIONS D AND E1 DO NOT INCLUDE MOLD FLASH, PROTRUSIONS OF GATE BURRS. MOLD FLASH, PROTRUSIONS, OR GATE BURRS SHALL NOT EXCEED 0.15 PER SIDE. DIMENSION D.
5. OPTIONAL CONSTRUCTION: AN ADDITIONAL TRIMMED LEAD IS ALLOWED IN THIS LOCATION. TRIMMED LEAD NOT TO EXTEND MORE THAN 0.2 FROM BODY.

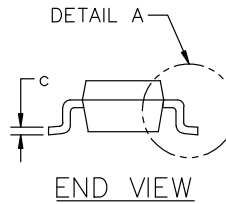
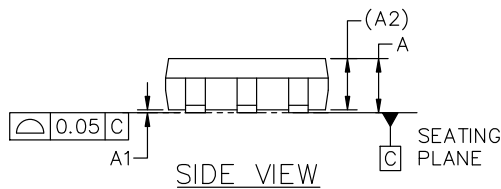

DIM	MILLIMETERS		
	MIN.	NOM.	MAX.
A	0.900	1.000	1.100
A1	0.010	0.055	0.100
A2	0.950 REF.		
b	0.250	0.375	0.500
c	0.100	0.180	0.260
D	2.850	3.000	3.150
E	2.500	2.750	3.000
E1	1.350	1.500	1.650
e	0.950 BSC		
L	0.200	0.400	0.600
θ	0°	5°	10°

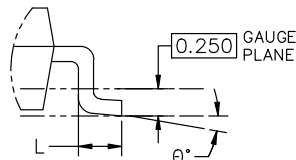

GENERIC MARKING DIAGRAM*

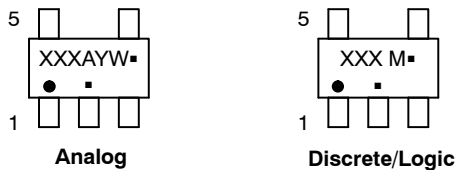

- XXX = Specific Device Code XXX = Specific Device Code
 A = Assembly Location M = Date Code
 Y = Year ▪ = Pb-Free Package
 W = Work Week
- = Pb-Free Package

(Note: Microdot may be in either location)

*This information is generic. Please refer to device data sheet for actual part marking. Pb-Free indicator, "G" or microdot "▪", may or may not be present. Some products may not follow the Generic Marking.

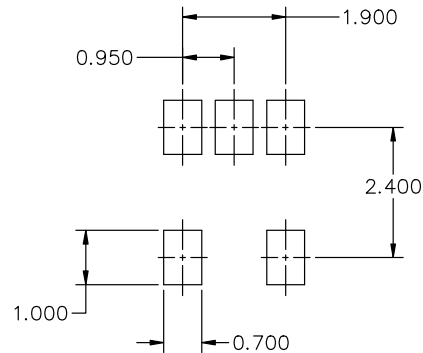

* FOR ADDITIONAL INFORMATION ON OUR Pb-FREE STRATEGY AND SOLDERING DETAILS, PLEASE DOWNLOAD THE ON SEMICONDUCTOR SOLDERING AND MOUNTING TECHNIQUES REFERENCE MANUAL, SOLDERM/D.

DOCUMENT NUMBER:	98ARB18753C	Electronic versions are uncontrolled except when accessed directly from the Document Repository. Printed versions are uncontrolled except when stamped "CONTROLLED COPY" in red.
DESCRIPTION:	TSOP-5 3.00x1.50x0.95, 0.95P	PAGE 1 OF 1

onsemi and ONSEMI are trademarks of Semiconductor Components Industries, LLC dba onsemi or its subsidiaries in the United States and/or other countries. onsemi reserves the right to make changes without further notice to any products herein. onsemi makes no warranty, representation or guarantee regarding the suitability of its products for any particular purpose, nor does onsemi assume any liability arising out of the application or use of any product or circuit, and specifically disclaims any and all liability, including without limitation special, consequential or incidental damages. onsemi does not convey any license under its patent rights nor the rights of others.

onsemi, **Onsemi**, and other names, marks, and brands are registered and/or common law trademarks of Semiconductor Components Industries, LLC dba "**onsemi**" or its affiliates and/or subsidiaries in the United States and/or other countries. **onsemi** owns the rights to a number of patents, trademarks, copyrights, trade secrets, and other intellectual property. A listing of **onsemi**'s product/patent coverage may be accessed at www.onsemi.com/site/pdf/Patent-Marking.pdf. **onsemi** reserves the right to make changes at any time to any products or information herein, without notice. The information herein is provided "as-is" and **onsemi** makes no warranty, representation or guarantee regarding the accuracy of the information, product features, availability, functionality, or suitability of its products for any particular purpose, nor does **onsemi** assume any liability arising out of the application or use of any product or circuit, and specifically disclaims any and all liability, including without limitation special, consequential or incidental damages. Buyer is responsible for its products and applications using **onsemi** products, including compliance with all laws, regulations and safety requirements or standards, regardless of any support or applications information provided by **onsemi**. "Typical" parameters which may be provided in **onsemi** data sheets and/or specifications can and do vary in different applications and actual performance may vary over time. All operating parameters, including "Typicals" must be validated for each customer application by customer's technical experts. **onsemi** does not convey any license under any of its intellectual property rights nor the rights of others. **onsemi** products are not designed, intended, or authorized for use as a critical component in life support systems or any FDA Class 3 medical devices or medical devices with a same or similar classification in a foreign jurisdiction or any devices intended for implantation in the human body. Should Buyer purchase or use **onsemi** products for any such unintended or unauthorized application, Buyer shall indemnify and hold **onsemi** and its officers, employees, subsidiaries, affiliates, and distributors harmless against all claims, costs, damages, and expenses, and reasonable attorney fees arising out of, directly or indirectly, any claim of personal injury or death associated with such unintended or unauthorized use, even if such claim alleges that **onsemi** was negligent regarding the design or manufacture of the part. **onsemi** is an Equal Opportunity/Affirmative Action Employer. This literature is subject to all applicable copyright laws and is not for resale in any manner.

ADDITIONAL INFORMATION

TECHNICAL PUBLICATIONS:

Technical Library: www.onsemi.com/design/resources/technical-documentation
onsemi Website: www.onsemi.com

ONLINE SUPPORT: www.onsemi.com/support

For additional information, please contact your local Sales Representative at www.onsemi.com/support/sales