



Design Note – DN06056/D

Power Supply For Audio Class D Amplifier

Device	Application	Input Voltage	Output Voltage	Output Current	Topology
CS51221	Audio	7.6-45 V	18V	8.3A	Boost

Table 1: CS51221 Audio Power Supply

Characteristic	Min	Typ	Max	Unit
Output Voltage	18.0453	18.0532	18.06	V
Output Current	1		8.3	A
Oscillator Frequency		140		kHz
Output Voltage Ripple		150		mVpk-pk
Load Regulation (Iout = 0.1-8.3A) Vin= 12V		-.693		mV/A
Line Regulation to 5V				
Iout = .1A)	0.28	0.31	0.34	%
Iout = 8.3A)	0.25	0.28	0.32	
Size	Length 80	Width 59	Height 31	mm

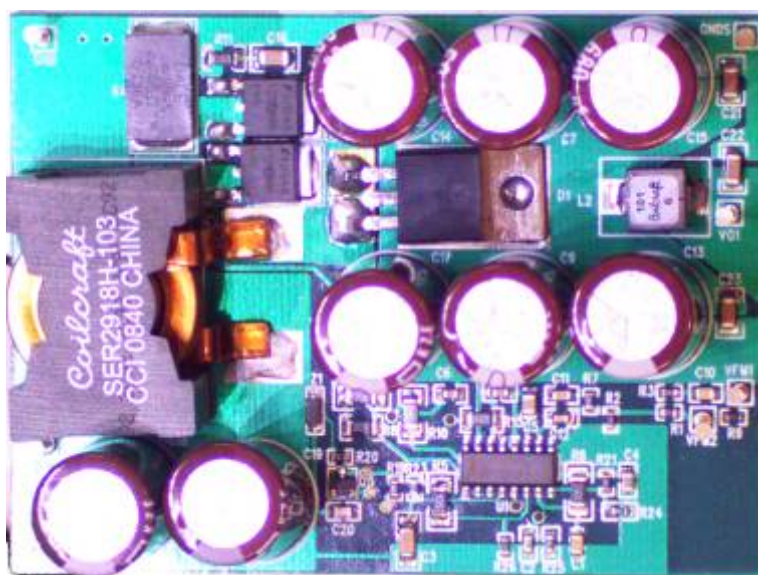

Figure 1: Demonstration Board Picture

Circuit Description

A boost power supply was developed for to feed 4 class D amplifiers and one auxiliary system. The design must minimize the use of through hole components, designed as small as possible on a 4 layer PCB, and only populated on the top side. The system level drawing is shown in Figure 2. The power supply is required to maintain an 18V output with input voltage variation from 7.6V to 18.4V. Above 18.4V the power supply will shutoff-minimizing losses and allow input voltage to flow to output voltage. The required voltage profile is shown in Figure 3.

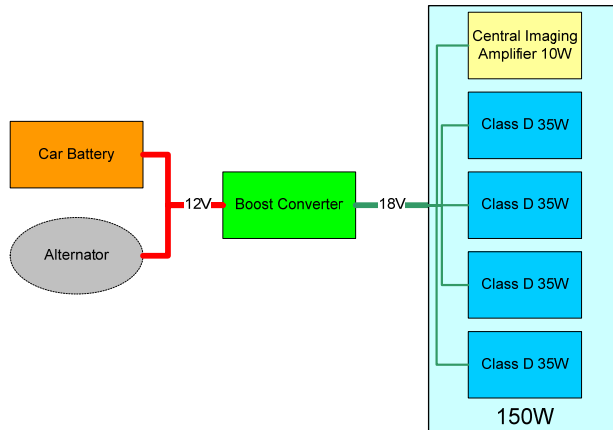

Figure 2: System Level Diagram of the Sony MCA 'Audiofile' radio

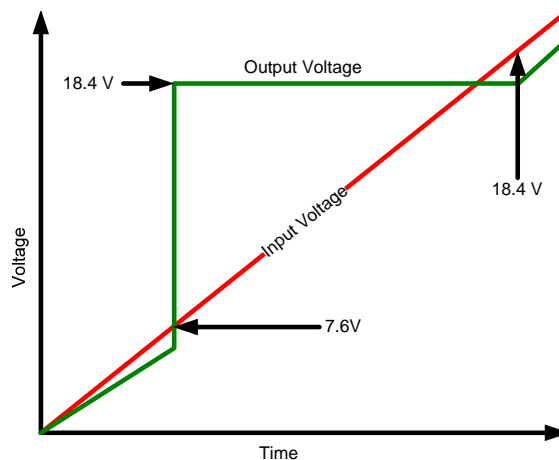

Figure 3: CS51221 Design Boost Curve

The design has the following features:

- Adjustable cycle by cycle current limiting
- Overvoltage Shutoff
- Undervoltage shutoff
- Can be synchronized to a higher frequency
- Wide operating range 7.6-18.4V operating and 18-45V nonoperating
- Programmable soft start
- Voltage feed forward

Performance Information

The following figures show typical performance of the evaluation board.

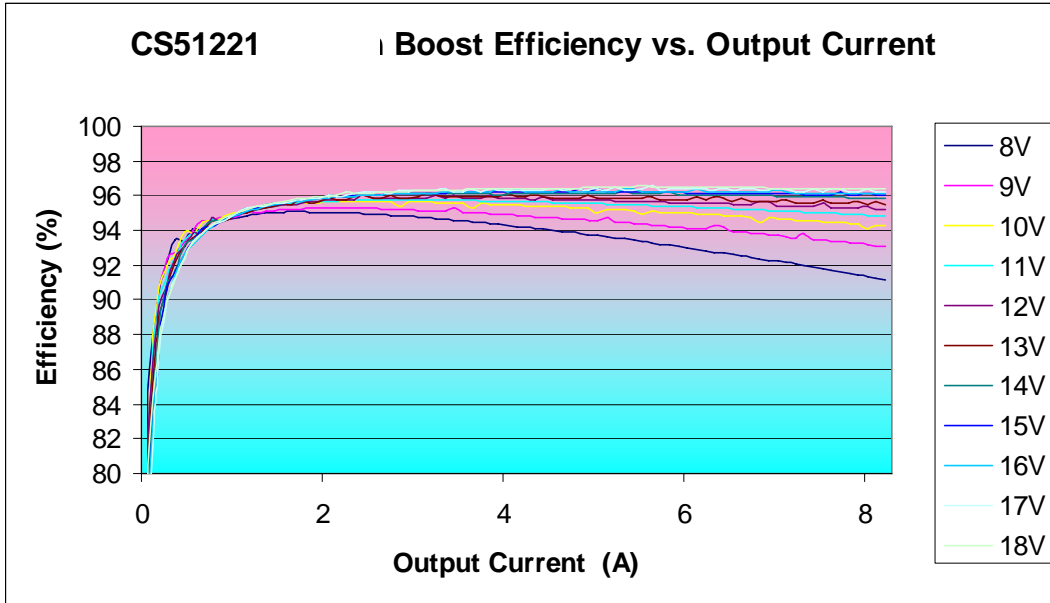

Figure 4: CS51221 Efficiency 8V – 18V input voltage with a 18V Output Voltage

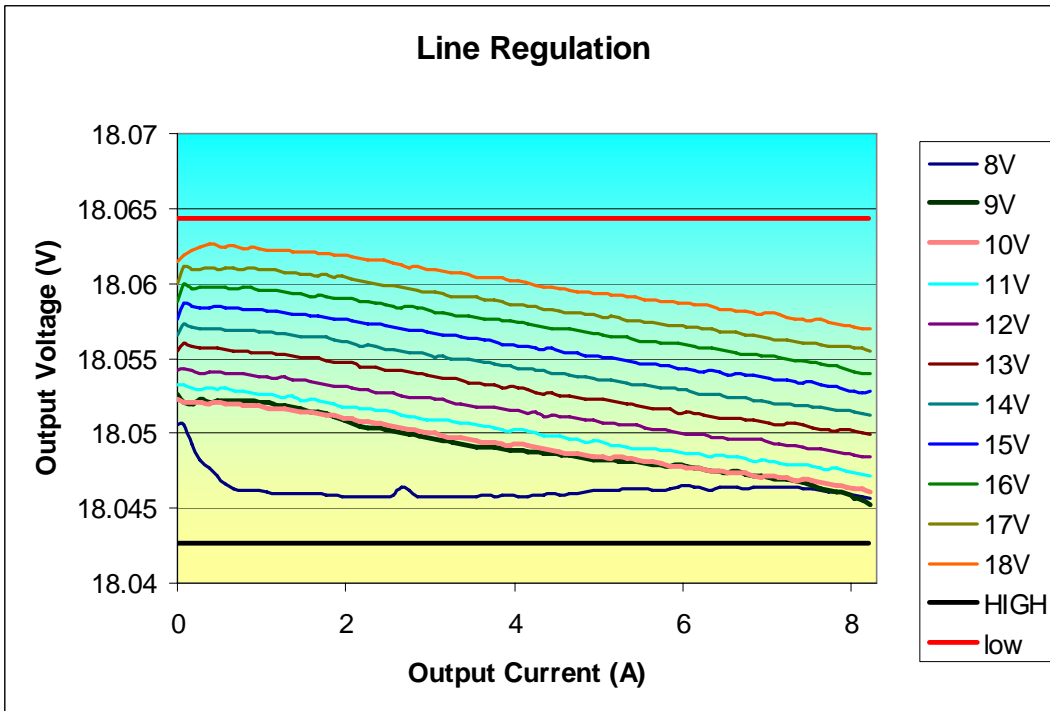

Figure 5: CS51221 Line Regulation

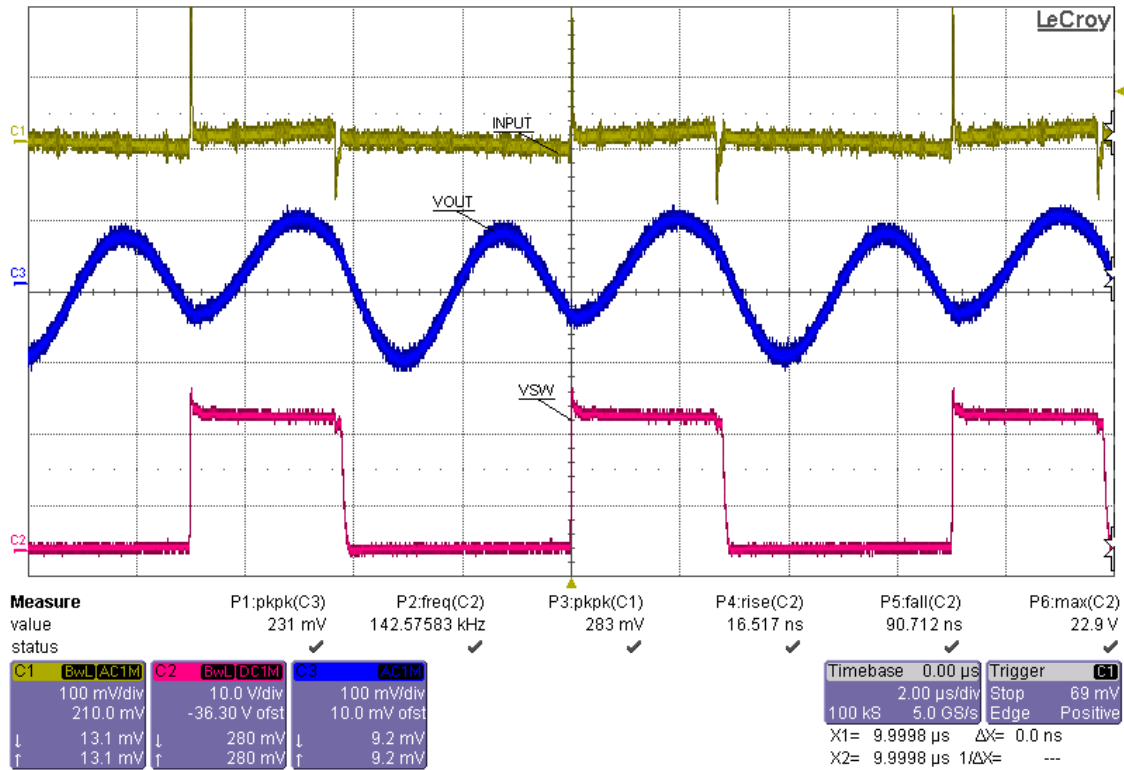

Figure 6: Input and Output Ripple Voltage $V_{in} = 8V$ $V_{out} = 18V$ $I_{out} = 8.3A$ 231 mVpp

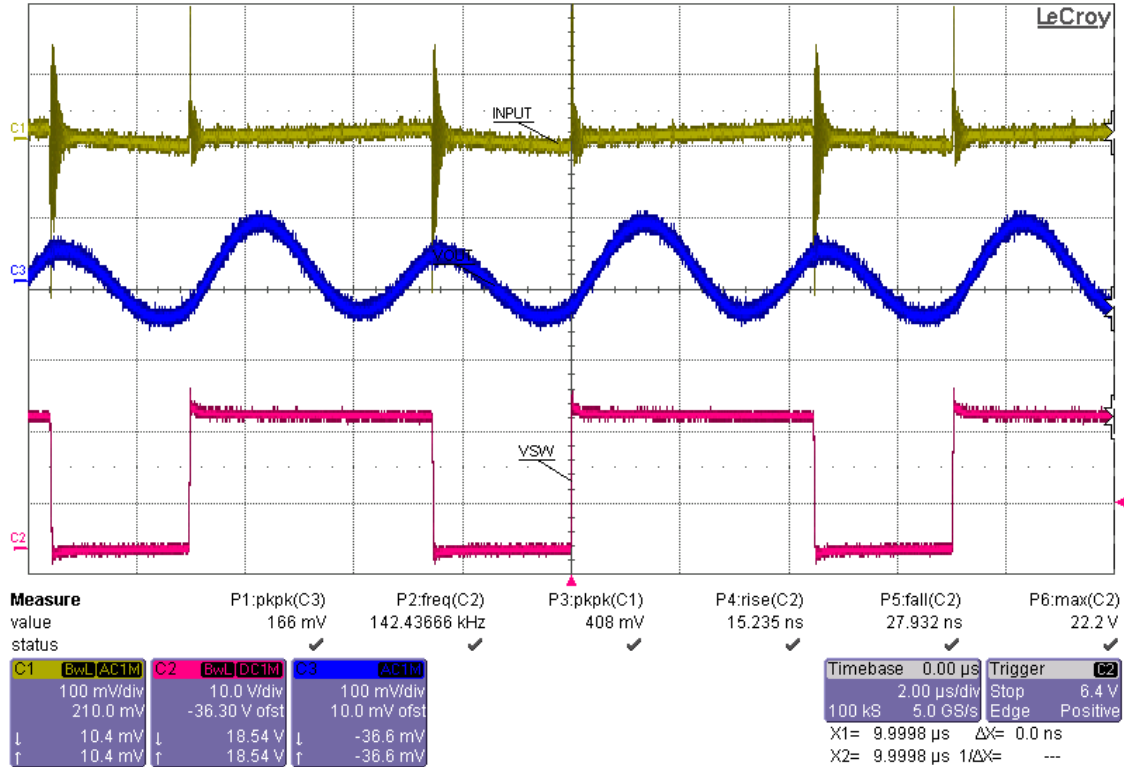

Figure 7: $V_{in} = 12V$ $V_{out} = 18V$ $I_{out} = 8.3A$ 166mVpp

ON Semiconductor Confidential – NDA Required

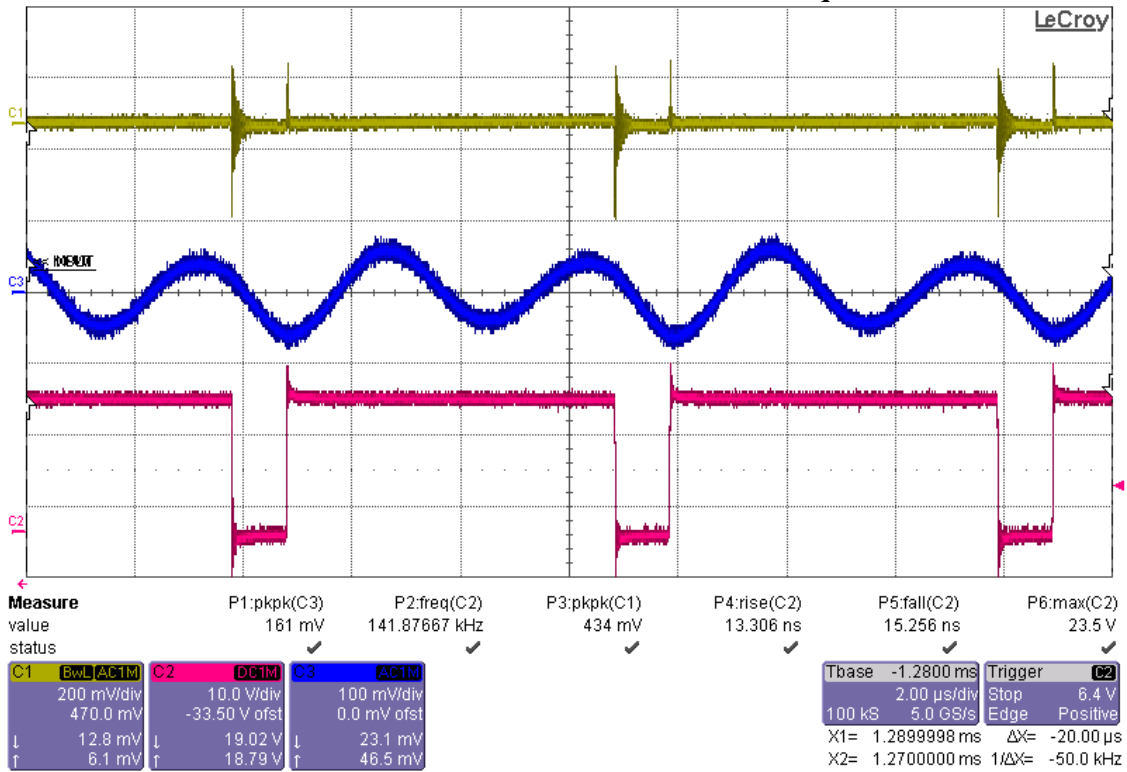

Figure 8: $V_{in} = 16V$ $V_{out} = 18V$ $I_{out} = 8.3A$ 161mVpp

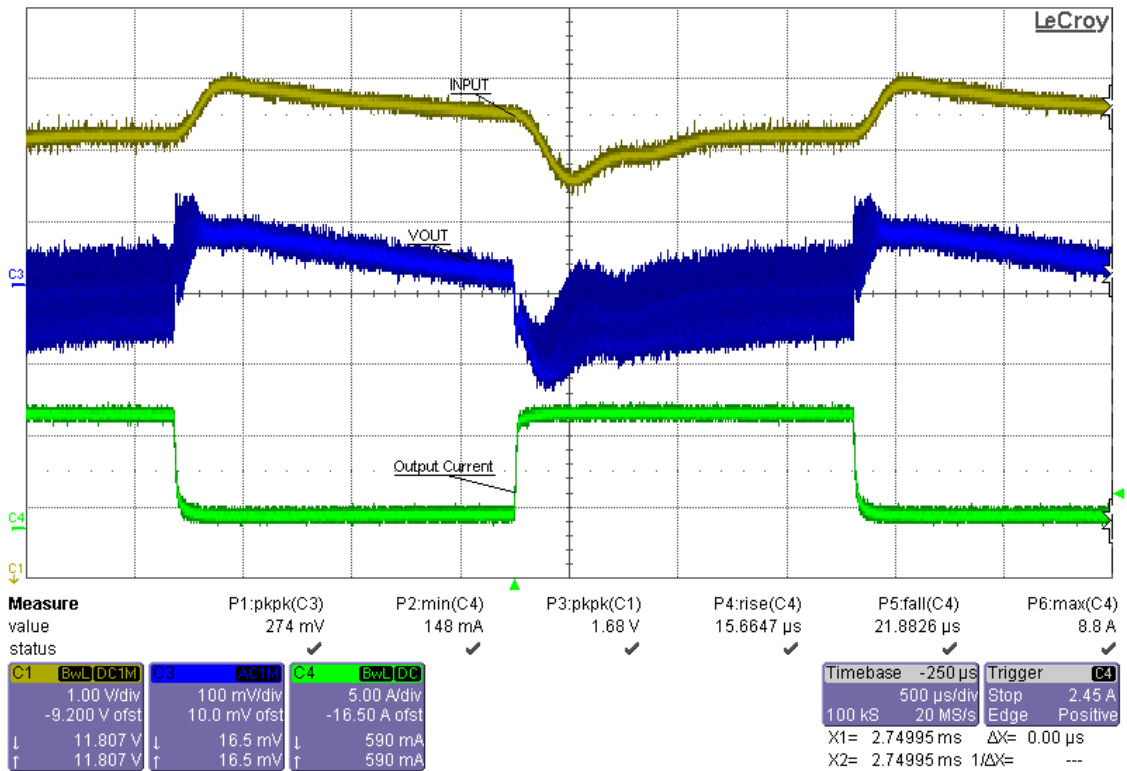

Figure 9: Transient Response Input Voltage = 12V output current step 1.0A to 8.0 A with 274 mV peek to peek

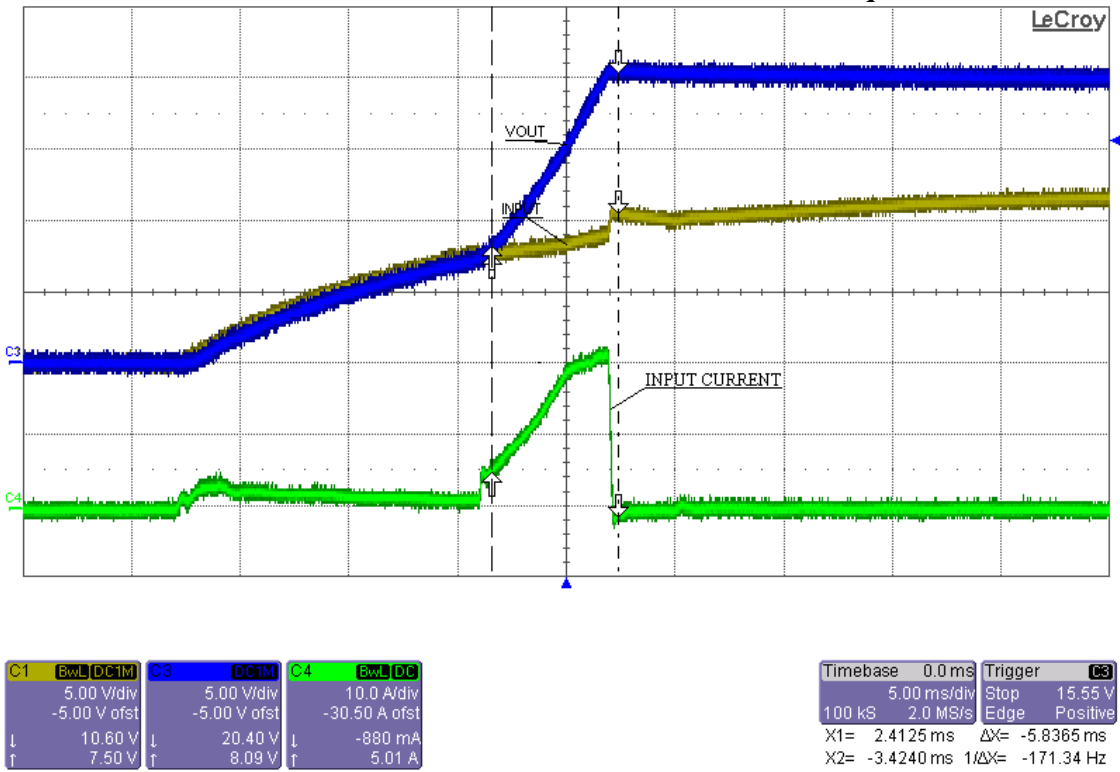

Figure 10: Soft Start Time is 5.8 ms from an Input voltage of 0V

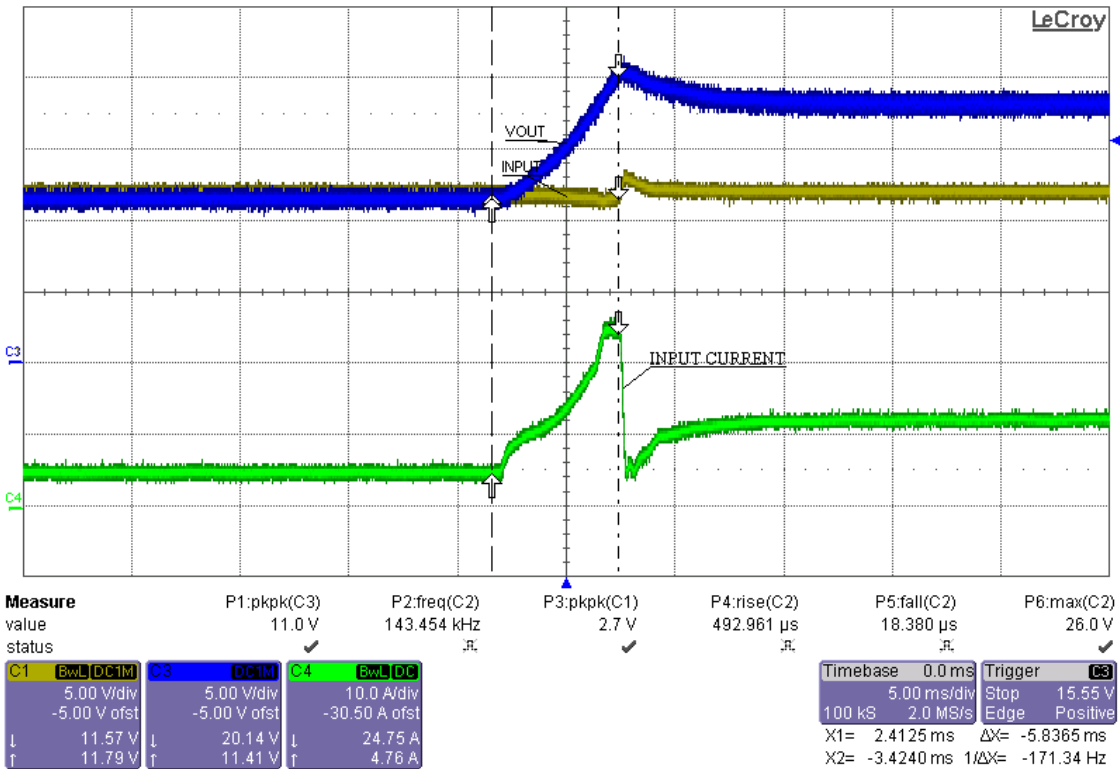

Figure 11: Soft Start Time is 5.8 ms from an Input voltage of 12V

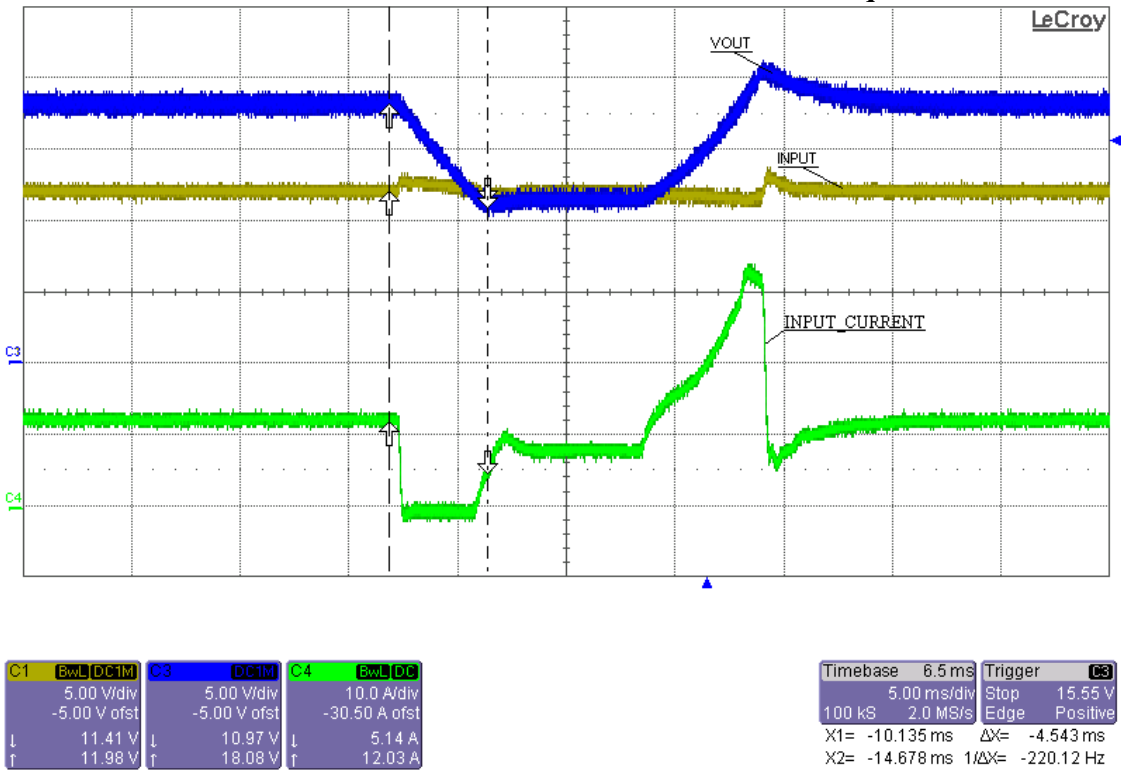

Figure 12: Soft Start and Soft Stop From 12V Volts

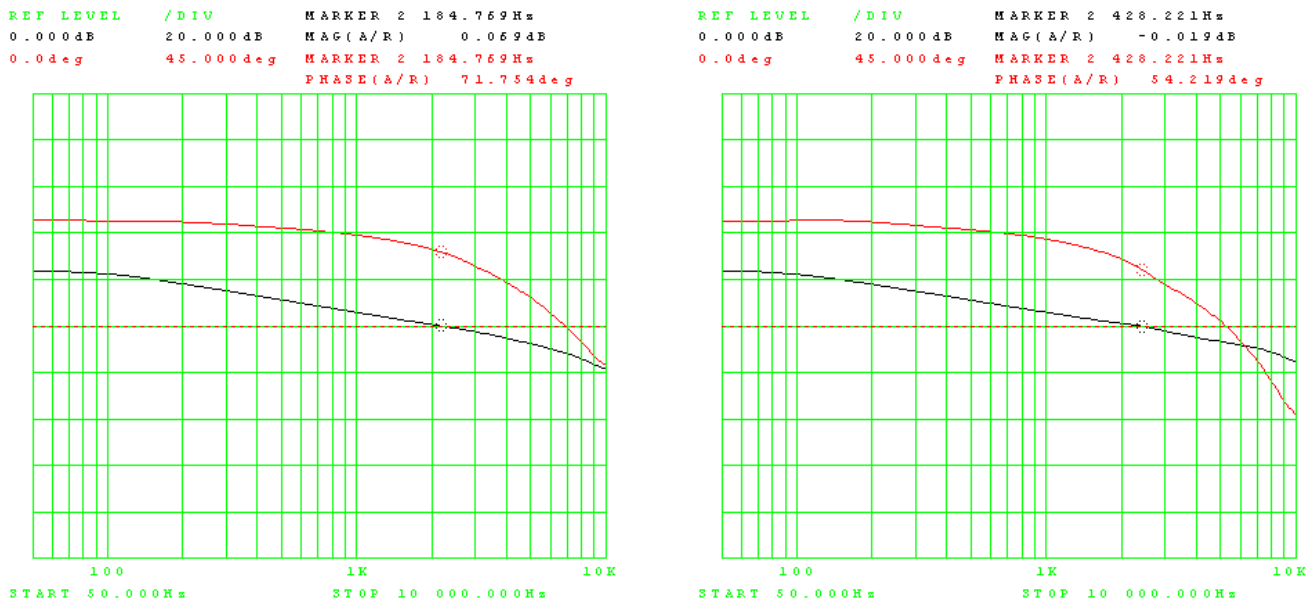

Figure 13: 8V Frequency Response 2.1 kHz and 2.4k Cross over at 71 and 54 Degrees of Phase Margin 2A Load at Full Load Right

ON Semiconductor Confidential – NDA Required

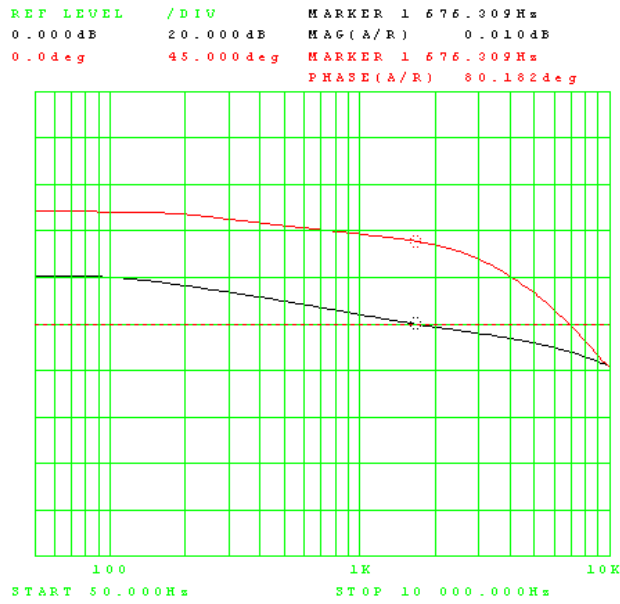

Figure 14: 12V Frequency Response 1.6kHz Cross over at 80 Full Load

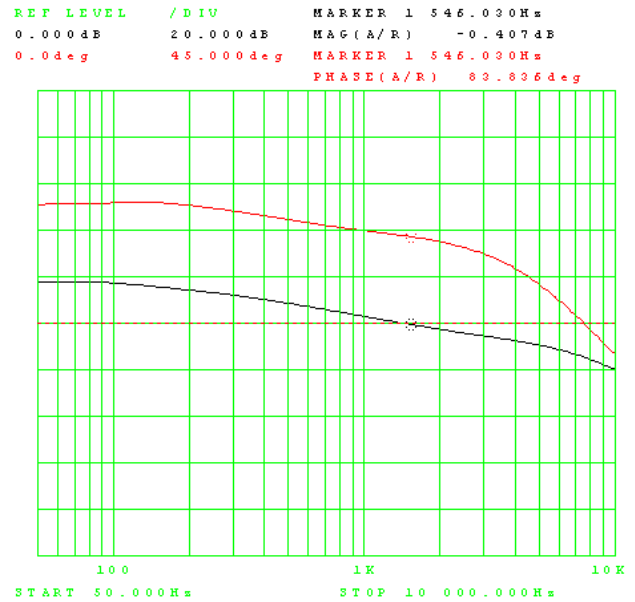
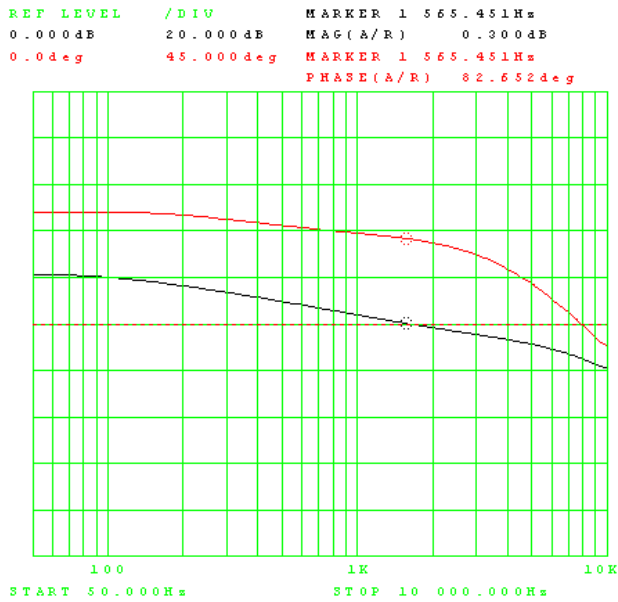

Figure 15: 16V Frequency Response 1.5 kHz and 1.5k Cross over at 82 and 83 Degrees of Phase Margin 2A Load at Full Load Right

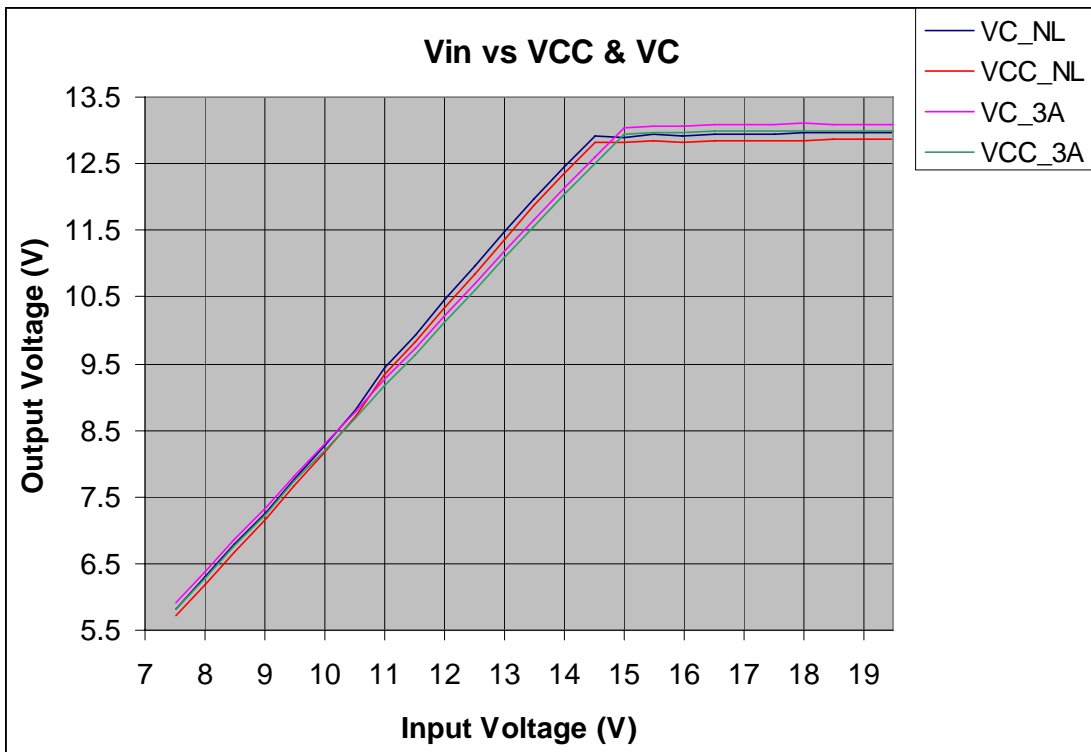

Figure 16: VCC and VC vs Input Voltage

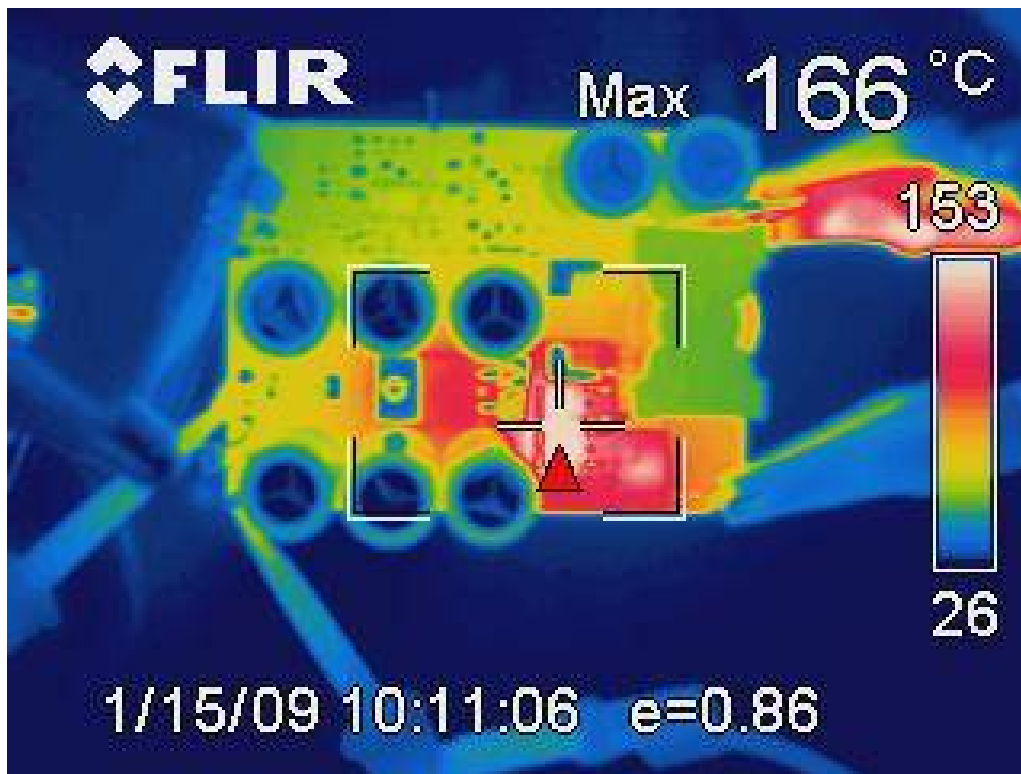

Figure 17: Thermal Image of PCB at 8V 8.3A Load with a 25C ambient



Figure 18: Thermal Image of PCB at 12V 8.3A Load with a 25C ambient

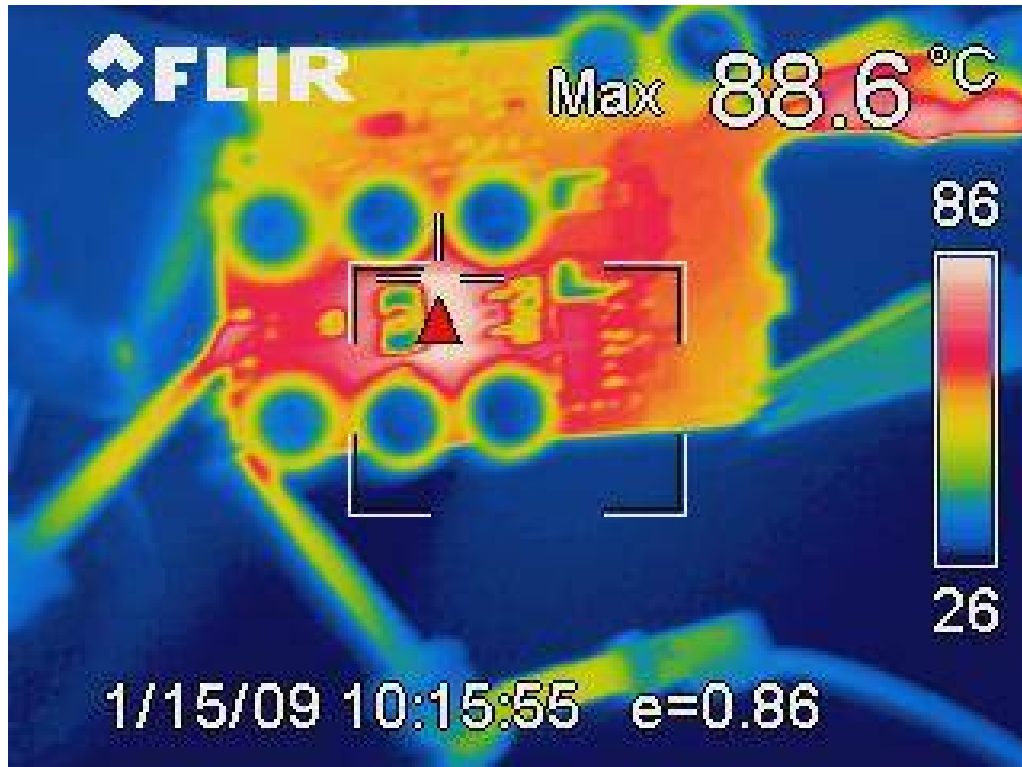

Figure 19: Thermal Image of PCB at 16V 8.3A Load with a 25C ambient

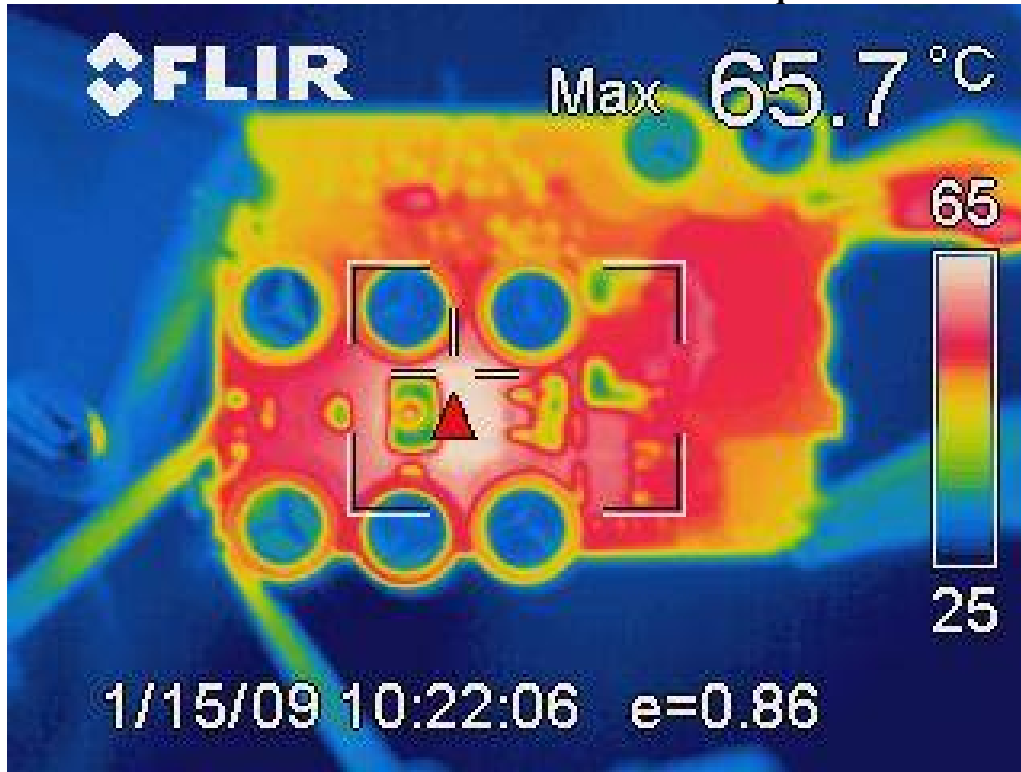

Figure 20: Thermal Image of PCB at 12V 4.15A Load with a 25C ambient

Schematic

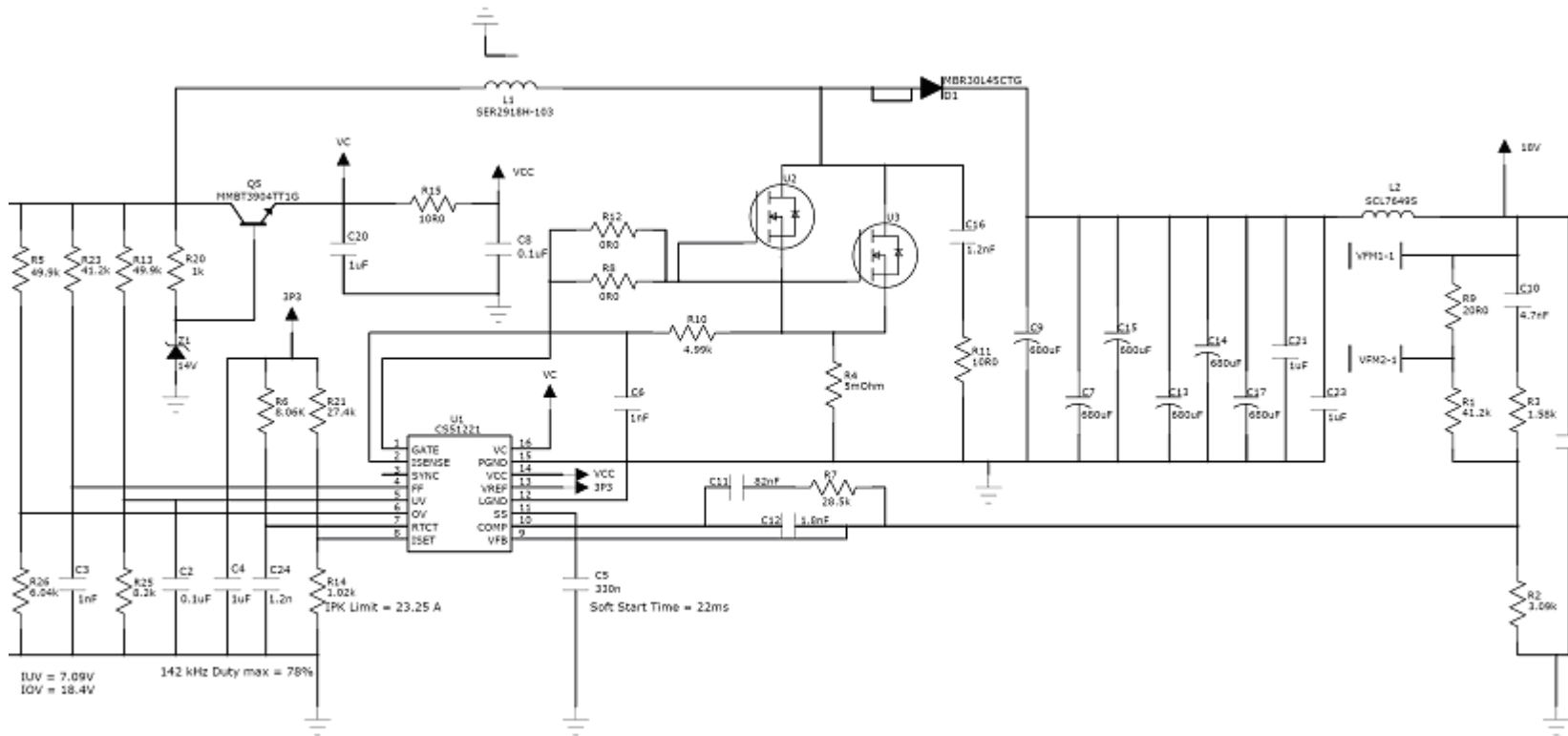

Figure 24: CS51221 Schematic

ON Semiconductor Confidential – NDA Required

Table 2 : CS51221 Bill of Materials

Designator	Quantity	Description	Value	Tolerance	FootPrint	Manufacturer	Manufacturer Part Number
C5	1	Ceramic Chip Capacitor 10V	330n	20%	805	AVX Corporation	0805ZC334JAT2A
C2 C8	2	Ceramic Chip Capacitor 25V	0.1uF	20%	603	AVX Corporation	06033C104MAT2A
C12	1	Ceramic Chip Capacitor 10V	1.8nF	10%	603	AVX Corporation	0603ZC272KAT2A
C6	1	Ceramic Chip Capacitor 50V	1nF	10%	603	AVX Corporation	0603ZC102KA72A
C4	1	Ceramic Chip Capacitor 6.3V	1uF	10%	603	AVX Corporation	06036D105KAT2A
C20	1	Ceramic Chip Capacitor 25V	1uF	20%	603	AVX Corporation	06033D105MAT2A
C10	1	Ceramic Chip Capacitor 100V	4.7nF	±10%	603	AVX Corporation	06031C472KAT2A
C11	1	Ceramic Chip Capacitor 10V	82nF	10%	603	AVX Corporation	0603ZC184KAT2A
C24	1	Ceramic Chip Capacitor 6.3V	1.2n	5%	805	AVX Corporation	08056A122JAT2A
C16	1	Ceramic Chip Capacitor 100V	1.2nF	10%	1206	AVX Corporation	12061A122KAT2A
C3	1	Ceramic Chip Capacitor 100V	1nF	10%	1206	AVX Corporation	12061C102KAT2A
C21 C23	2	Ceramic Chip Capacitor 50V	1uF	10%	1206	AVX Corporation	12065C105KAT2A
C22	1	Ceramic Chip Capacitor 50V	4.7uF	±10%	1210	AVX Corporation	12105C475KAT2A
U1	1	Enhanced Voltage Mode PWM Controller	3V Ref	NA	SOIC 16	ON Semiconductor	CS51221
C7 C13-15 C9 C17-19	8	Electrolytic Capacitor	680uF	20%	12.5X25	United Chemicon	EKZE500ELL681MK30S
D1	1	Schottky Power Rectifier	30A 45V	NA	TO-220	ON Semiconductor	MBR30L45CTG
Q5	1	General Purpose NPN Transistor	40V 200mA	NA	SOT-23	ON Semiconductor	MMBT3904TT1G
Z1	1	Zener Diode	14V	±5%	SOD-123	ON Semiconductor	MMSZ5244BT1G
U2-3	2	N MOSFET 8.1mOhm	60V 50A	NA	DPAK	Infineon	IPB081N06L3G
R5	1	SMT Resistor	49.9k	1%	1206	Vishay	CRCW120649K9FKEA
R14	1	SMD Resistor	1.02k	±1.0%	603	Vishay / Dale	CRCW06031K02FKEA
R3	1	SMD Resistor	1.58k	±1.0%	603	Vishay / Dale	CRCW06031K58FKEA
R20	1	SMD Resistor	1k	±1.0%	603	Vishay / Dale	CRCW060310K0FKEA
R9	1	SMD Resistor	20R0	±1.0%	603	Vishay / Dale	CRCW060320R0FKEA
R21	1	SMD Resistor	27.4k	±1.0%	603	Vishay / Dale	CRCW060327K4FKEA
R7	1	SMD Resistor	28.5k	±1.0%	603	Vishay / Dale	CRCW06033K01FKEA
R2	1	SMD Resistor	3.09k	±1.0%	603	Vishay / Dale	CRCW06033K09FKEA
R1 R23	2	SMD Resistor	41.2k	±1.0%	603	Vishay / Dale	CRCW060341K2FKEA

ON Semiconductor Confidential – NDA Required

Table 2 : CS51221 Bill of Materials

Designator	Quantity	Description	Value	Tolerance	FootPrint	Manufacturer	Manufacturer Part Number
R13	1	SMD Resistor	49.9k	±1.0%	603	Vishay / Dale	CRCW060349K9FKEA
R26	1	SMD Resistor	6.04k	±1.0%	603	Vishay / Dale	CRCW06036K04FKEA
R25	1	SMD Resistor	8.2k	±1.0%	603	Vishay / Dale	CRCW06038K20FKEA
R8 R12	2	SMD Resistor	0R0	±5.0%	1206	Vishay / Dale	CRCW12060000Z0EA
R11 R15	2	SMD Resistor	10R0	±5.0%	1206	Vishay / Dale	CRCW120610R0FKEA
R10	1	SMD Resistor	4.99k	±1.0%	1206	Vishay / Dale	CRCW12064K99FKEA
R6	1	SMD Resistor	8.06K	±1.0%	1206	Vishay / Dale	CRCW12068K06FKEA
R4	1	SMD Resistor	5mOhm	±1.0%	4527	Vishay / Dale	WSR55L00F
L2	1	SMT Inductor 0.17mOhm	.1 uH	10%	7.5mmX 7.6mm	Coilcraft	SLC7649S-101KL_
L1	1	SMT Inductor	33 uH	10%	27.94mmX 27.9mm	Coilcraft	SER2918H-103

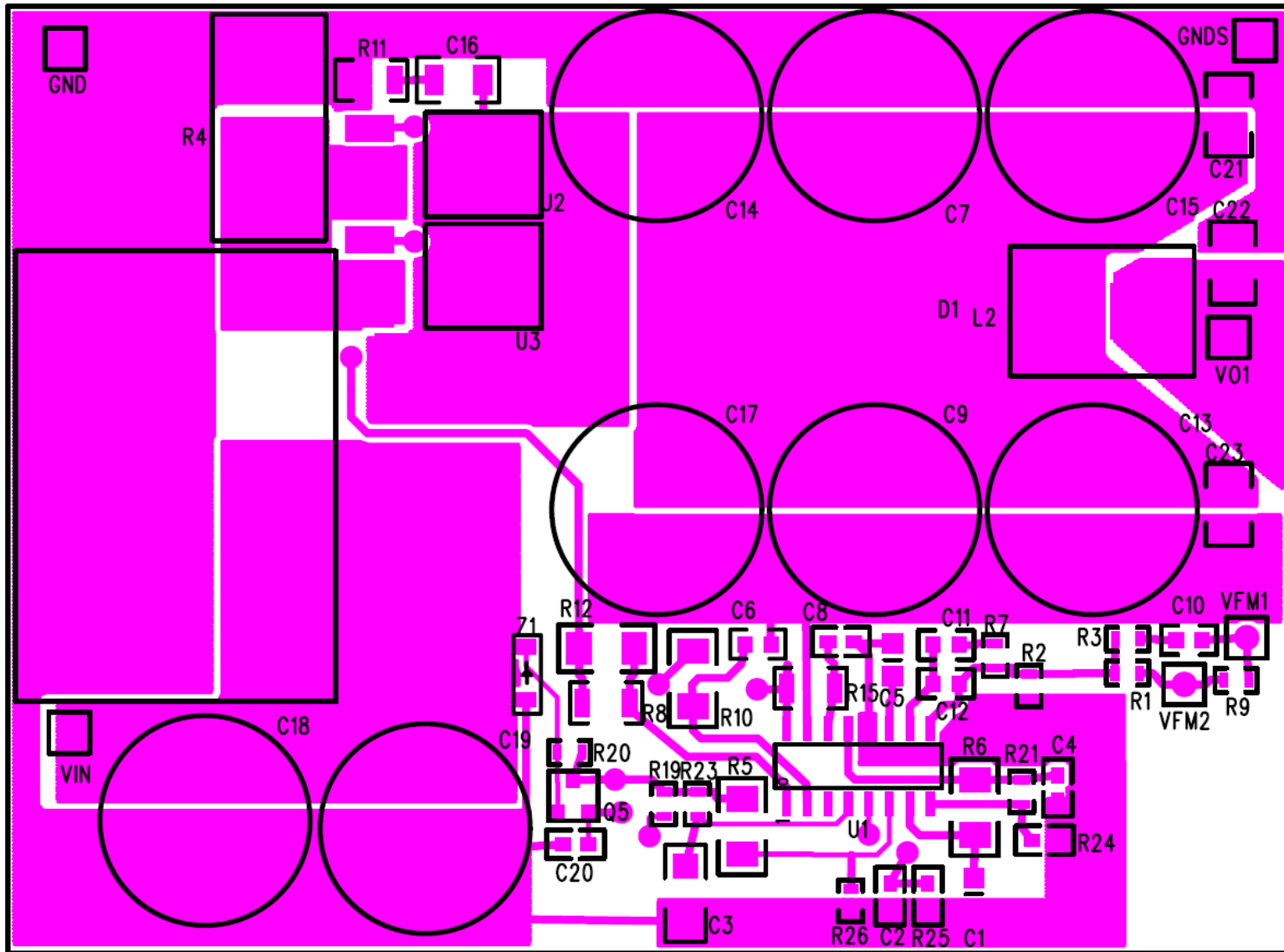

Figure 25: Layout Top

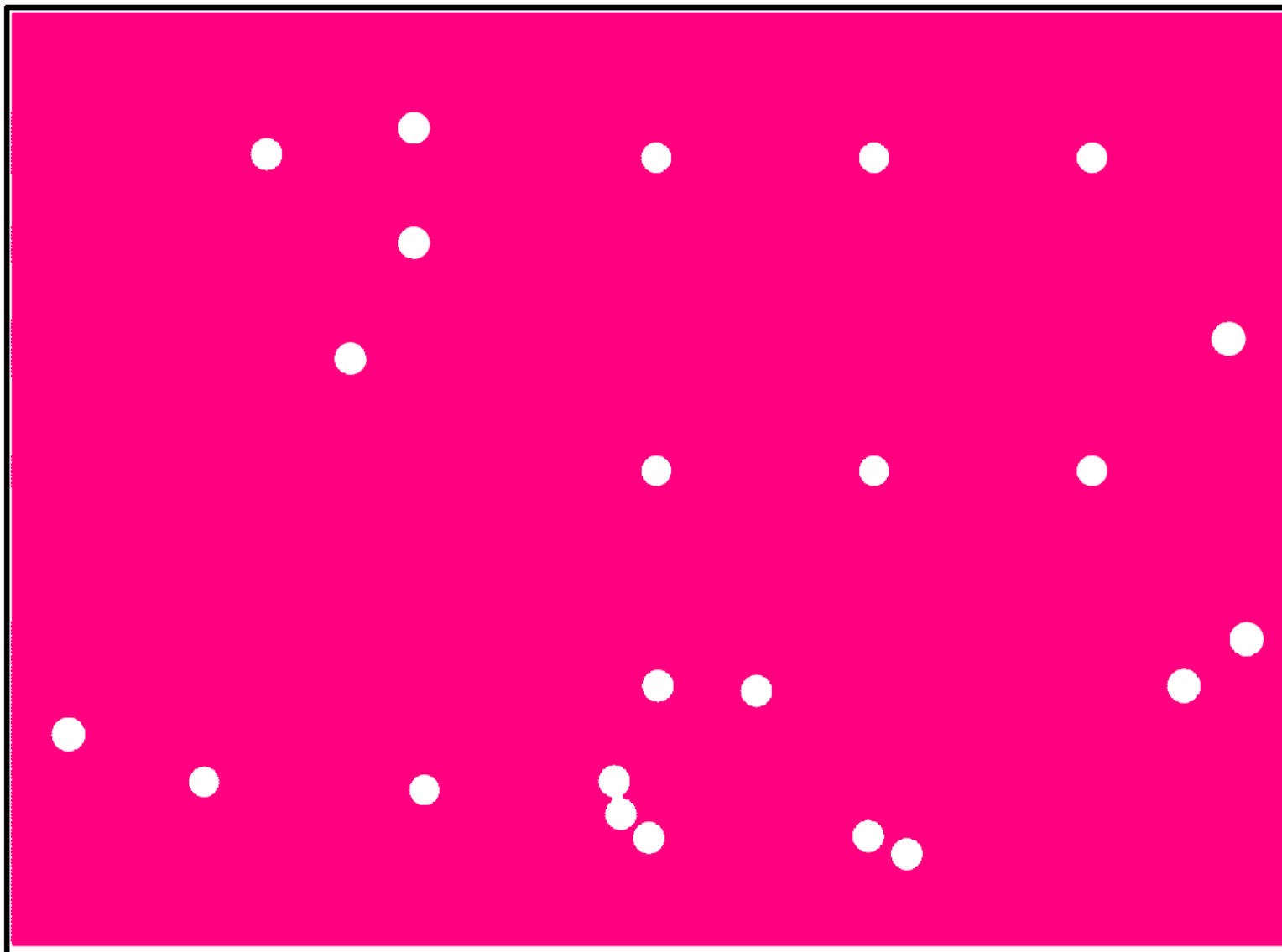

Figure 26: Layout Inner Top

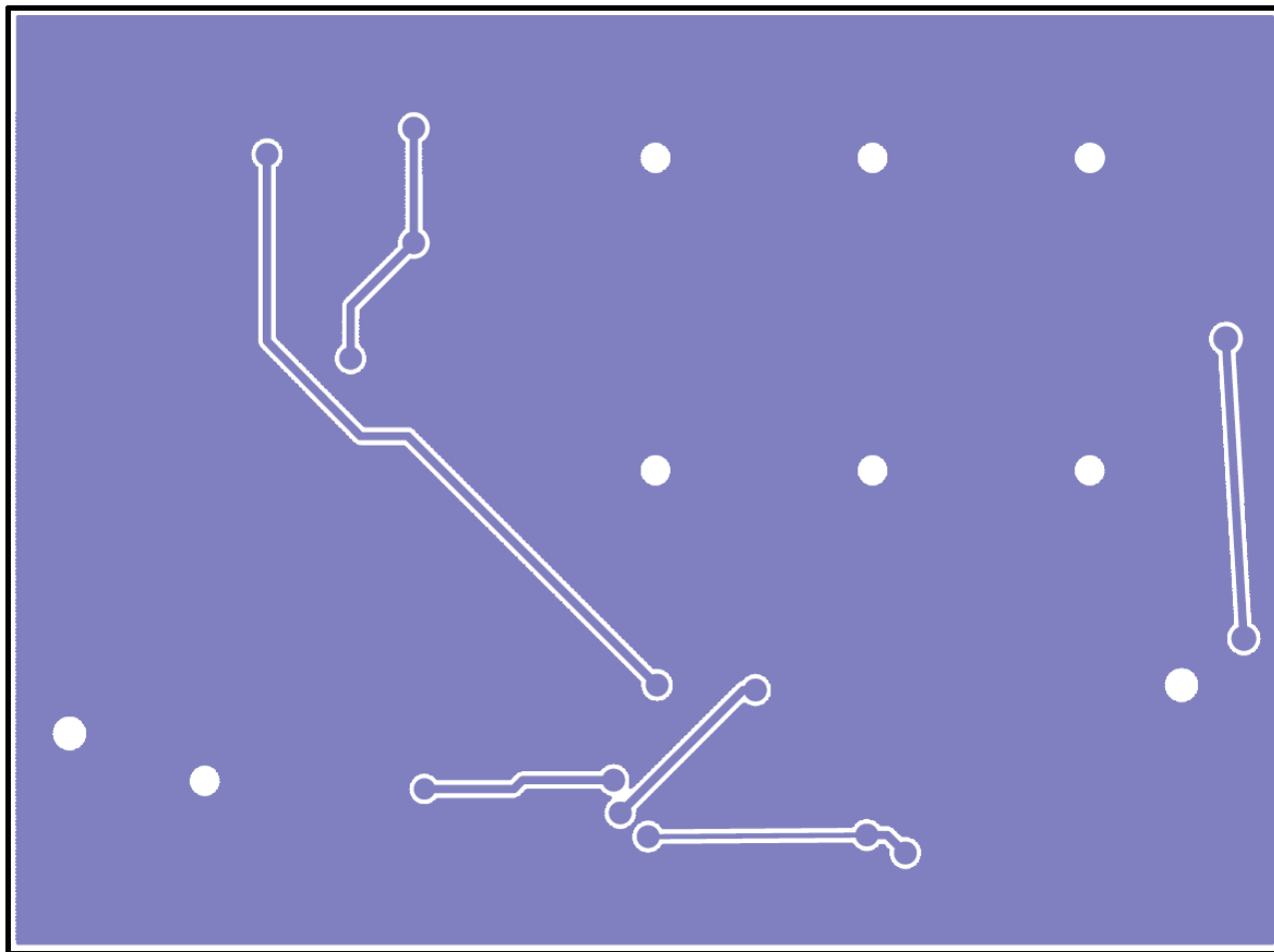

Figure 27: Layout Inner Bottom

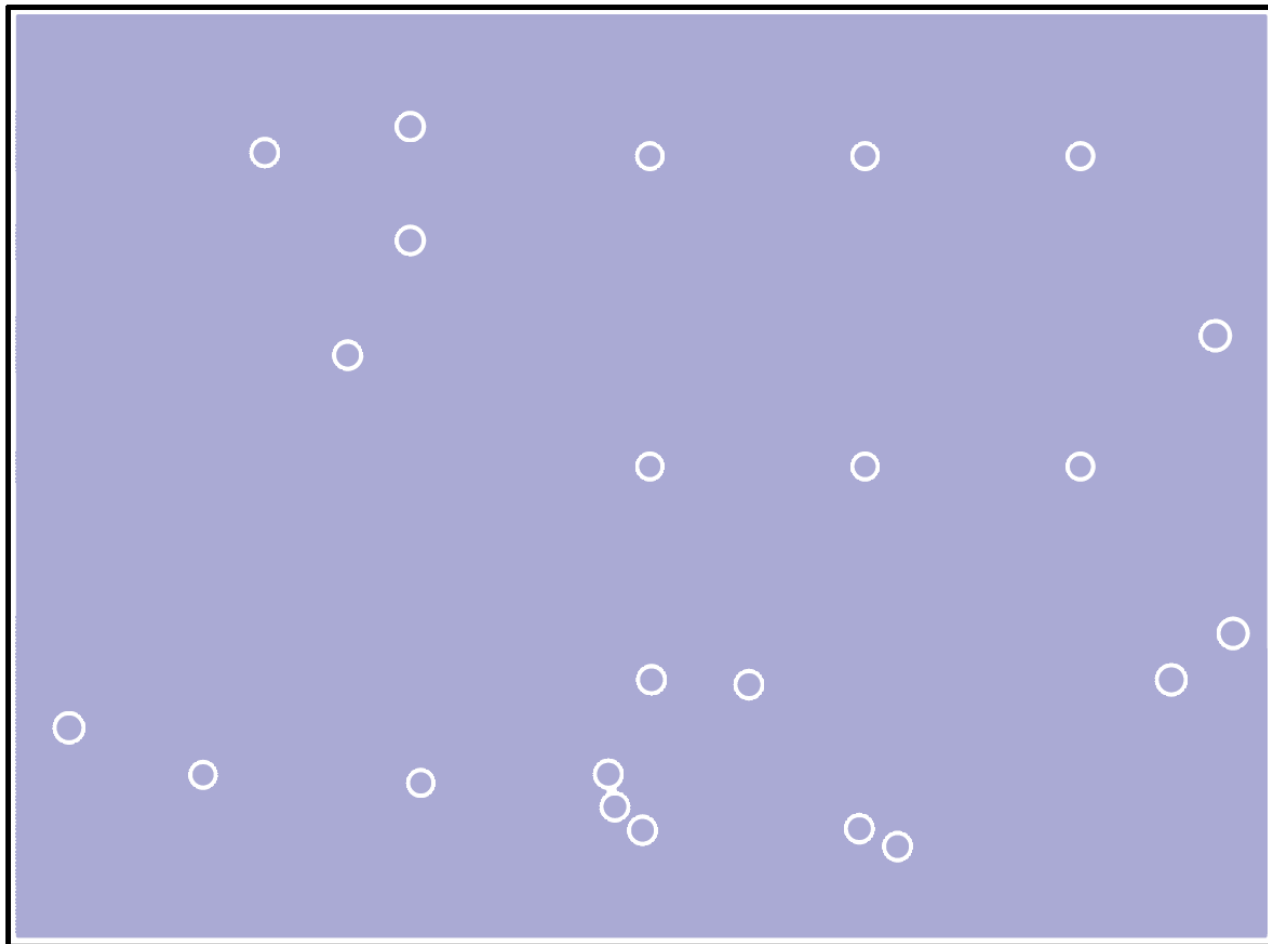

Figure 28: Layout Bottom

High Current Reverse Polarity Protection

The boost converter input current at low line is over 21 A creating large losses when standard reverse polarity protection is used. The power loss when using a schottky diode capable of 30A are as follows:

$$P_{DIODE} = IV \xrightarrow{\text{Solve}} 21A * 0.7V = 14.7W \quad P_{MOSFET} = I^2 R \xrightarrow{\text{Solve}} \frac{P_{MOSFET}}{I^2} = R = \frac{2W}{21A^2} = 4.5m\Omega$$

Since the MOSFET will be mostly on the user need only consider the RDSon as the switching losses can be negated. The final consideration is to determine how the MOSFET might be turned on when appropriate and turned off when the voltage is reversed. Figure 29 shows one solution for the low side reverse polarity protection

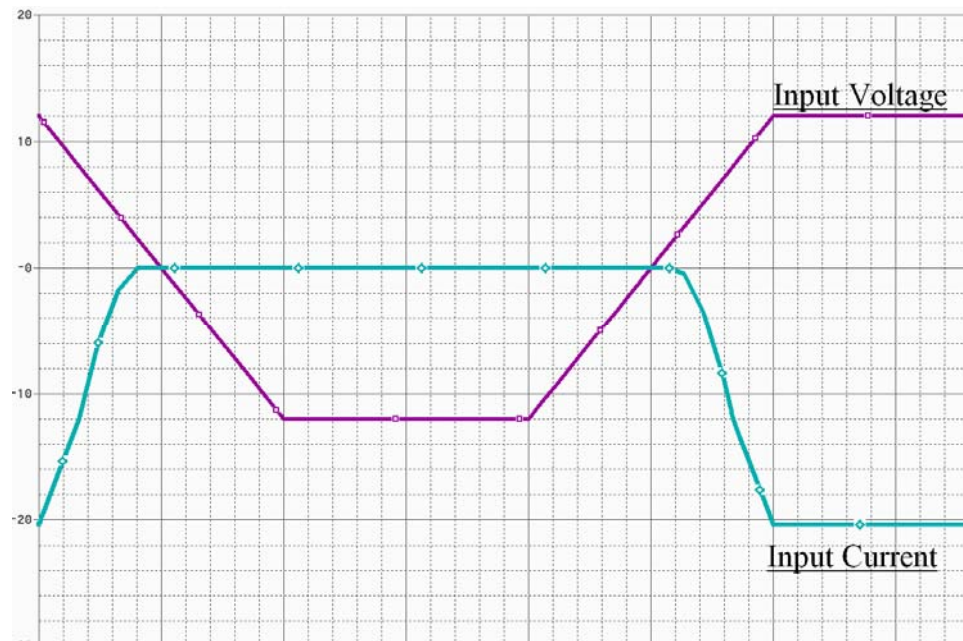
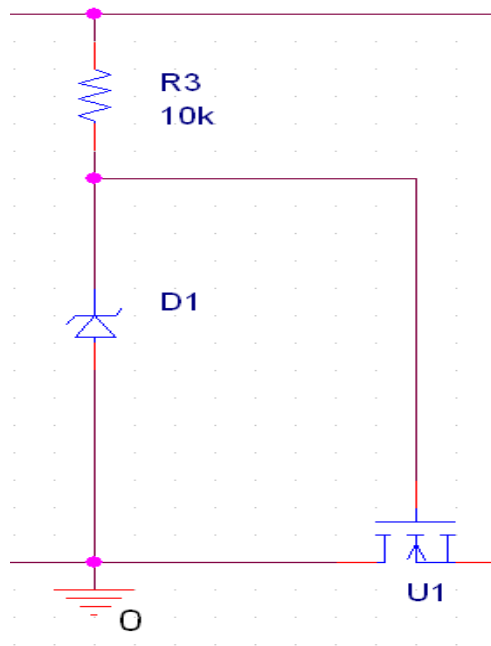

Figure 29: Low Side Reverse Polarity Protection and Simulated Results

Current Sharing of Parallel MOSFETS

ON Semiconductor Confidential – NDA Required

Efficiency Calculator

An efficiency calculator was constructed for boost converter applications to predict the effect of component changes on system efficiency and to aid the designer in making critical design tradeoffs. The user should enter all of the information they know about the design then change parameters like R_{DSon} and frequency to gauge the system sensitivity to the parameter. Figure 30 Shows the predicted efficiency of the design at 140kHz. The efficiency can also be predicted for the 375 kHz, 417kHz, and 500kHz .

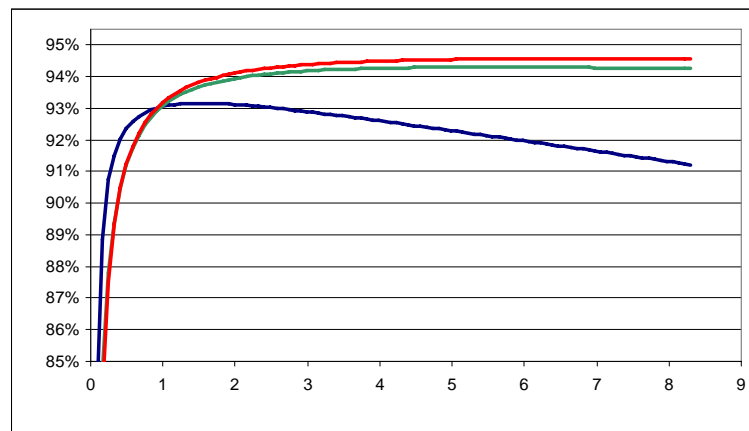
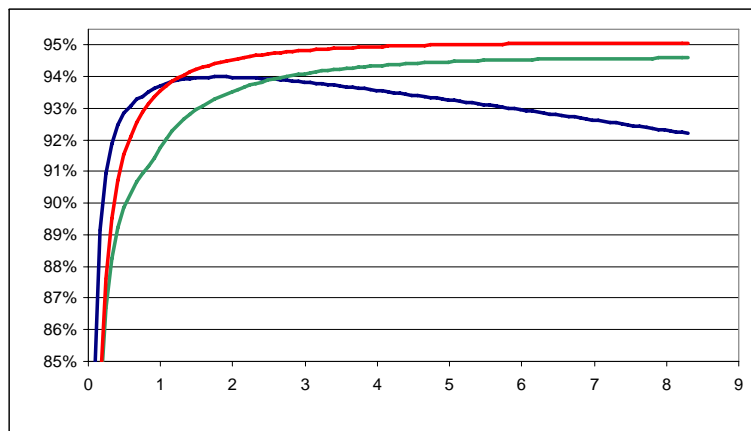

Figure 30: Predicted Efficiency of Design at 140 kHz Left 375 kHz Blue = 8V, Green = 12V, Red = 18V

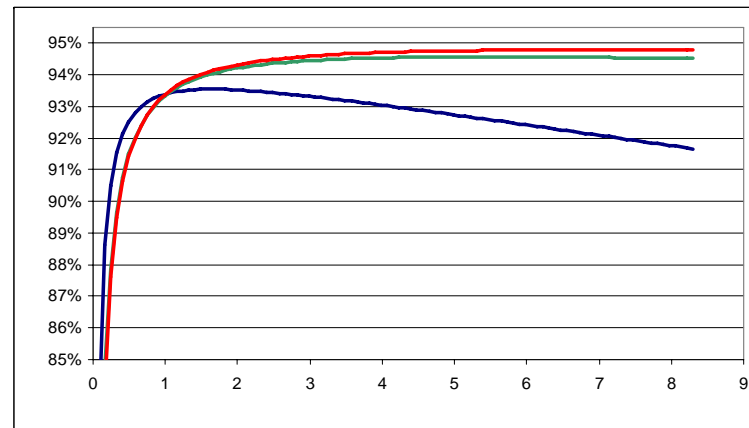
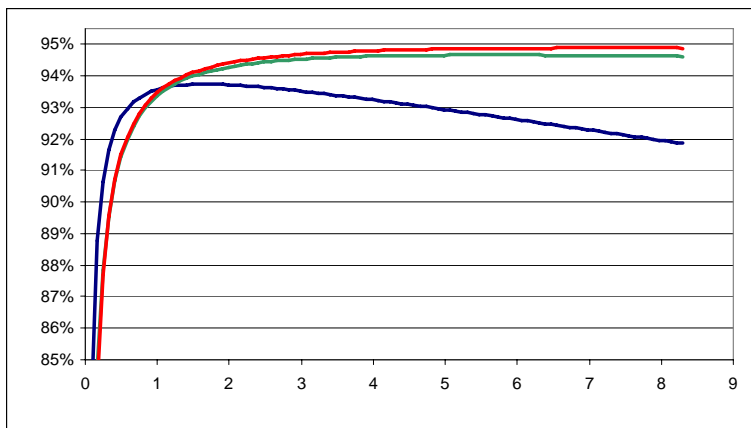

Figure 30: Predicted Efficiency of Design at 417 kHz Left 500 kHz Blue = 8V, Green = 12V, Red = 18V

ON Semiconductor Confidential – NDA Required

The on resistance of the MOSFET makes a large impact at low line on the system level efficiency. The charts below compare the Fairchild FDD13AN06A0CT with the On Semiconductor NTB45N06LT4G which has similar gate charge characteristics, and the NTB75N06G which has similar RDSon. The Infineon IPB081N06L3G can also be used for higher efficiency.

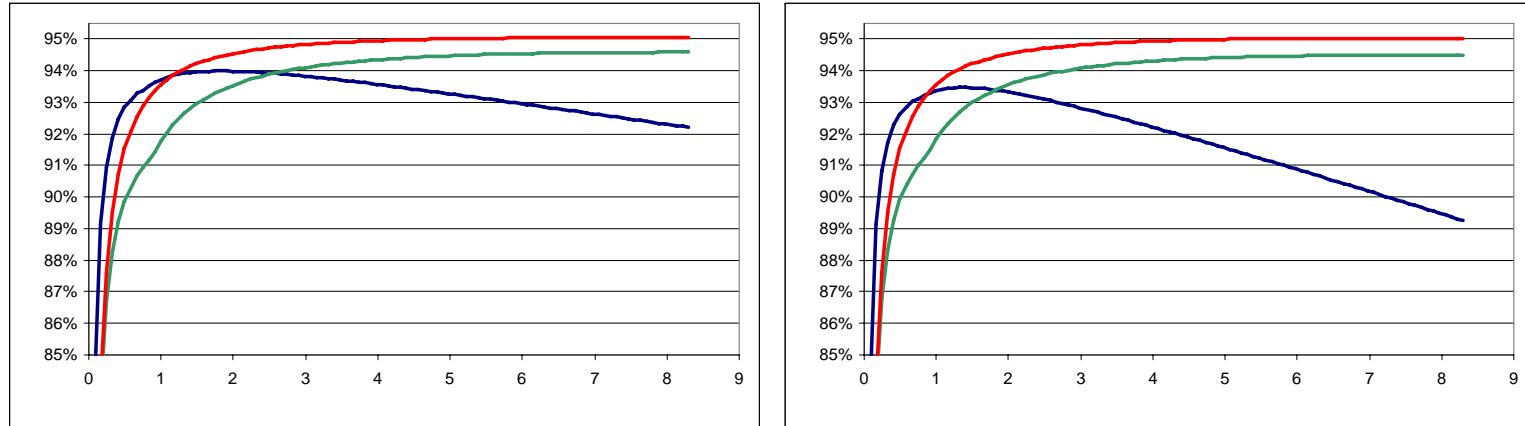

Figure 30: Predicted Efficiency of Design at 140 kHz FDD13AN06A0CT Left and NTB45N06LT4G right Blue = 8V, Green = 12V, Red = 18V

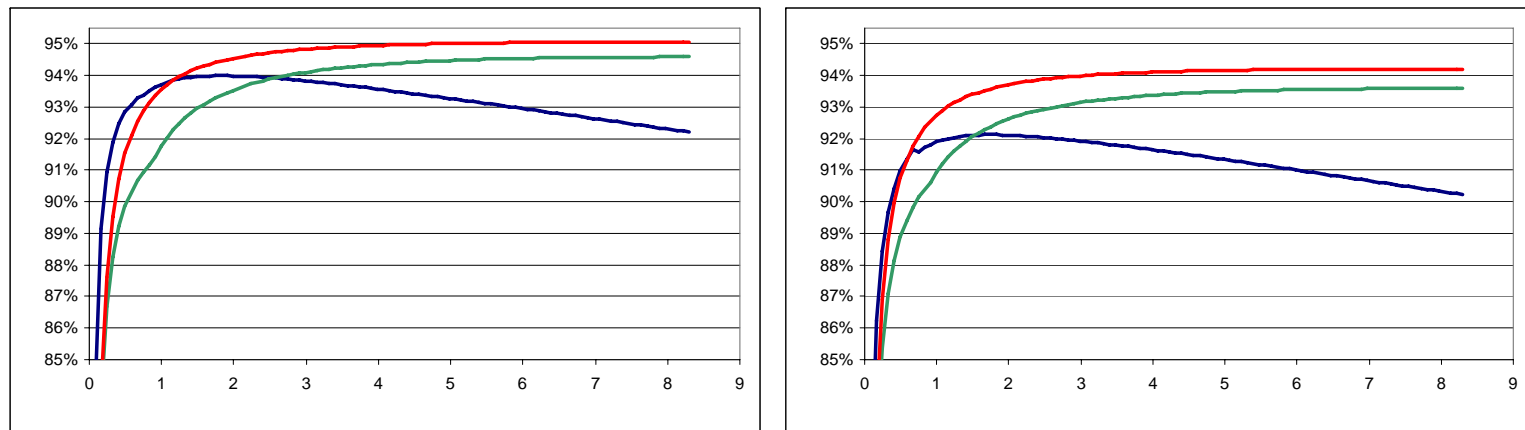

Figure 31: Predicted Efficiency of Design at 140 kHz FDD13AN06A0CT Left and NTB75N06G right Blue = 8V, Green = 12V, Red = 18V

ON Semiconductor Confidential – NDA Required

When calculating the component values for the worst case it is important to find to local ambient temperature. One way to predict the local temperature of components is to use linear super position as discussed in [1]. Using linear super position one can take a series of measurements of a PCB temperature shown in Figure 32 when major power component are made to dissipate a know power. The temperatures are then recorded and coefficients are calculated to determine the influence of all components running simultaneously at a given area of interest shown in Figure 33 . Once the data is collected the only remaining information needed is the power dissipation of each component.

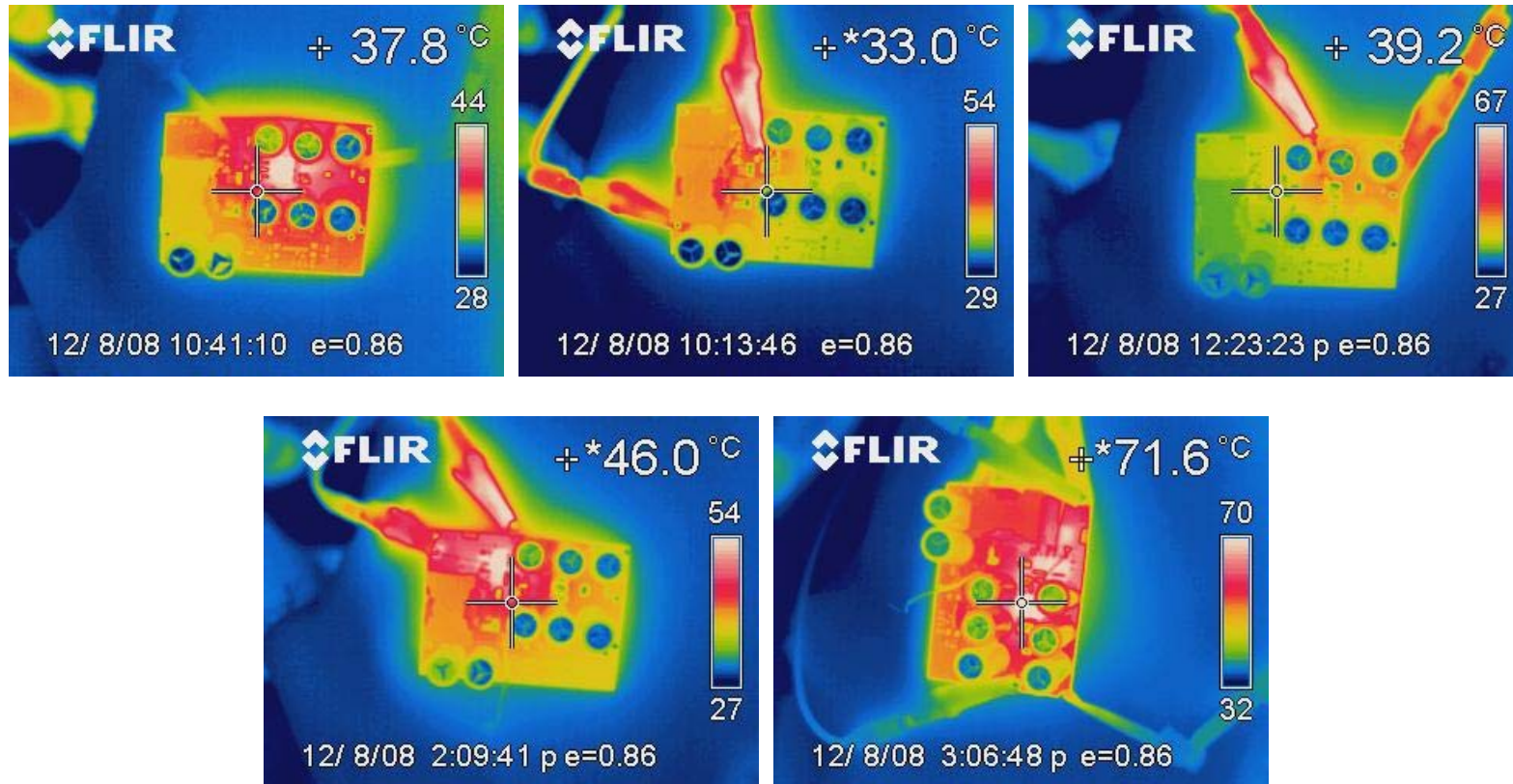

Figure 32: Steady State Thermal Image Captures on Individual Component Heating

ON Semiconductor Confidential – NDA Required

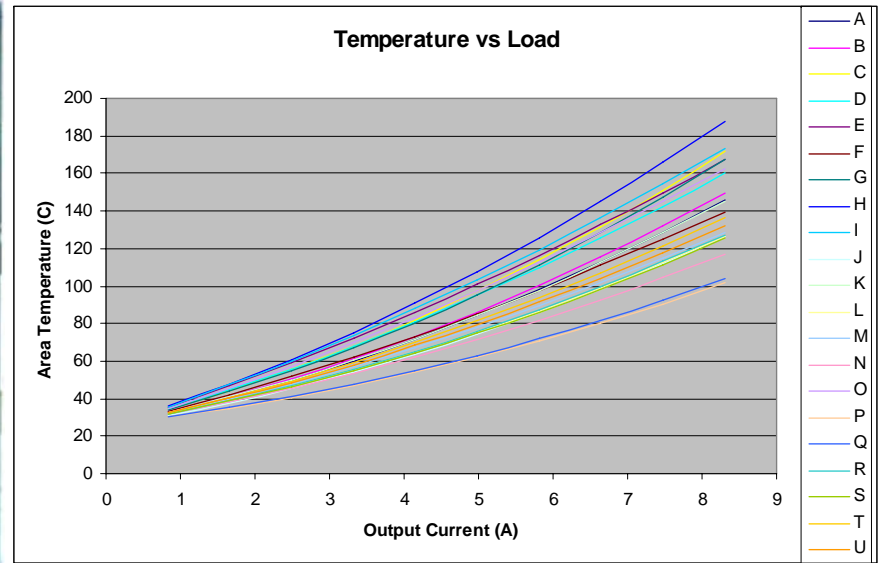
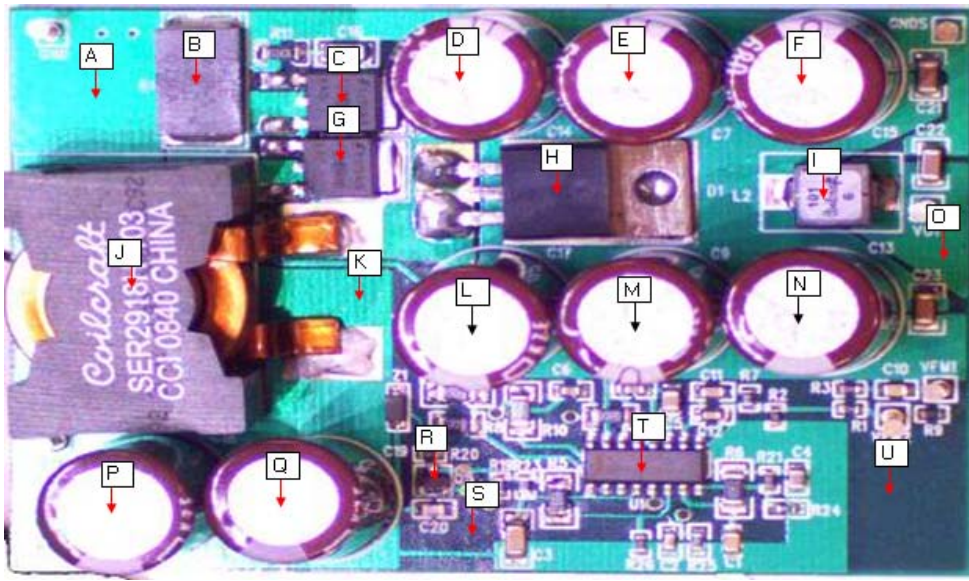

Figure 33: Area of Interest Selected for Temperature Evaluation and Calculated Thermal Data

© 2009 ON Semiconductor.

Disclaimer: ON Semiconductor is providing this design note "AS IS" and does not assume any liability arising from its use; nor does ON Semiconductor convey any license to its or any third party's intellectual property rights. This document is provided only to assist customers in evaluation of the referenced circuit implementation and the recipient assumes all liability and risk associated with its use, including, but not limited to, compliance with all regulatory standards. ON Semiconductor may change any of its products at any time, without notice.

Design note created by Tim Kaske and Bryan McCoy, e-mail: Tim.Kaske@onsemi.com ; Bryan.McCoy@onsemi.com