

ON Semiconductor Device Nomenclature

Prepared by: Steve West
ON Semiconductor



ON Semiconductor®

<http://onsemi.com>

REFERENCE MANUAL

Whenever possible, ON Semiconductor uses the following numbering systems in the naming of their products.

The ESD/TVS, small signal diode and transistor, and thyristor portfolios have no single standard naming

Historical Nomenclature Notes

During its history, ON Semiconductor has been part of another company, and has acquired other companies and product lines. In order to maintain consistency for customers, part numbers have not changed, wherever possible. The following prefixes may indicate the original manufacturer:

- ADP** – Analog Devices, Inc.
- ADT** – Analog Devices, Inc.
- AMIS** – AMI Semiconductor
- ASM** – PulseCore
- CAT** – Catalyst Semiconductor
- CS** – Cherry Semiconductor
- MC** – Motorola

convention. They consist of many industry standard nomenclatures, along with several market targeted naming conventions. For any questions, please contact your local ON Semiconductor sales representative.

Current Nomenclature Notes

Analog	2
CMOS Logic	3
Analog Switch	3
Clock and Data Management	4
Integrated Solutions	6
MOS Power	7
Power MOSFETs – SO–8 (MiniMOS™), Micro8™, SOT–223, and TSOP–6	8
Bipolar Power	9
Rectifiers	11
FMO Bump	12
Ambient Light Sensors	12
Contact Image Sensors & Modules	13
Photo Diode Arrays	14
LED/Lighting Products	14
Former Catalyst Products	
I ² C Serial EEPROMs	15
SPI Serial EEPROMs	15
Microwire Serial EEPROMs	16
Low Drop Out (LDO) Products	16
Supervisor Products	17
Charge Pumps, LED Drivers and I/O Bus Products ..	17
Digitally Programmable Potentiometer and Supervisor with Memory Products	18

TND310

Naming Convention for Analog Devices

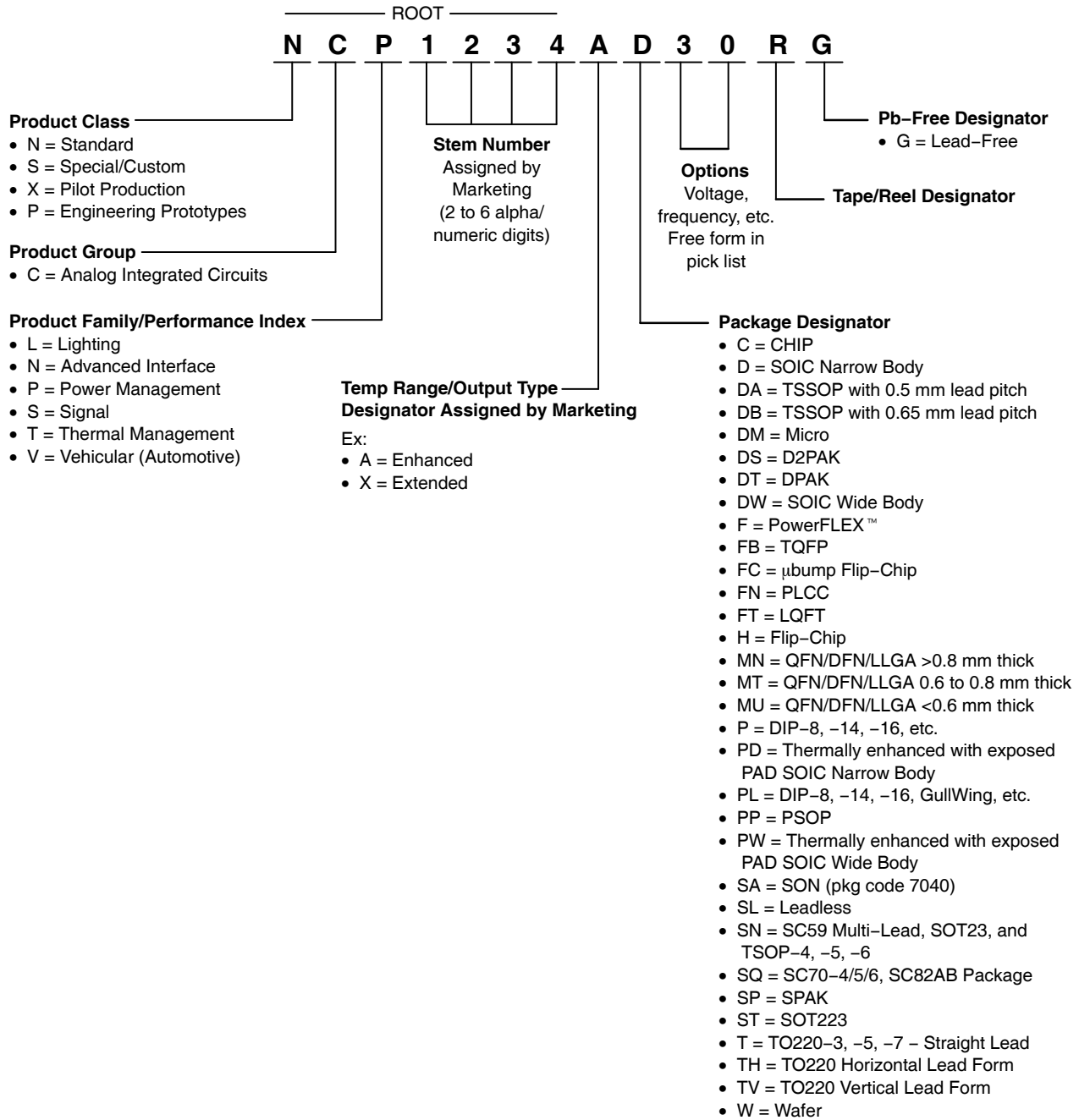

TND310

Naming Convention for CMOS Logic Family Devices

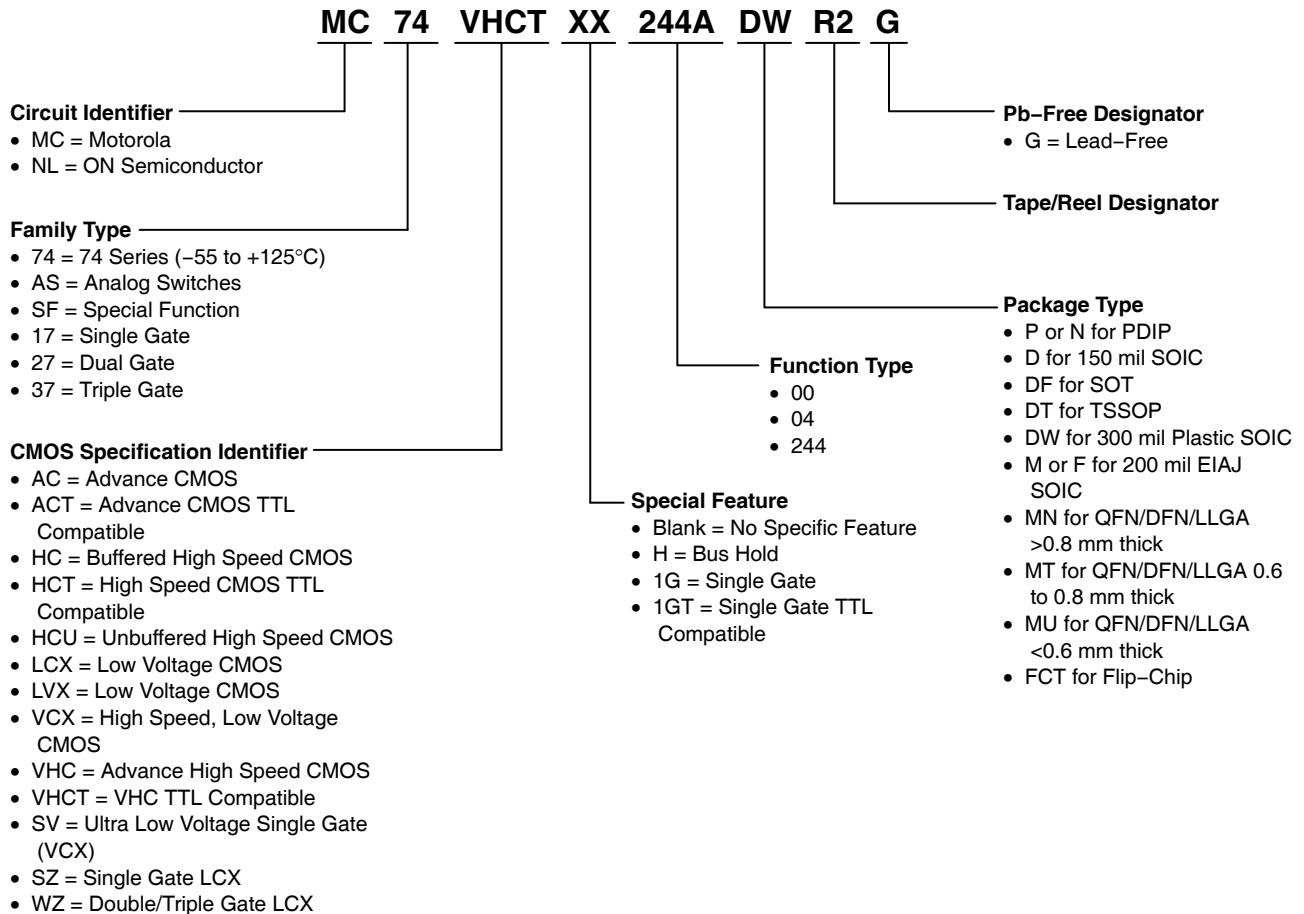

Naming Convention for Analog Switch Devices

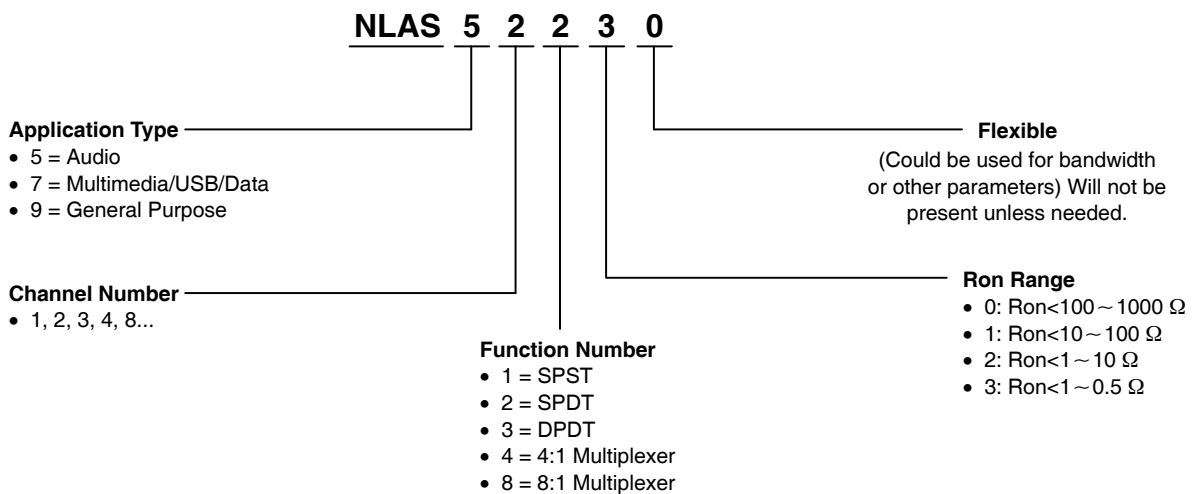

TND310

Naming Convention for Clock and Data Management Devices

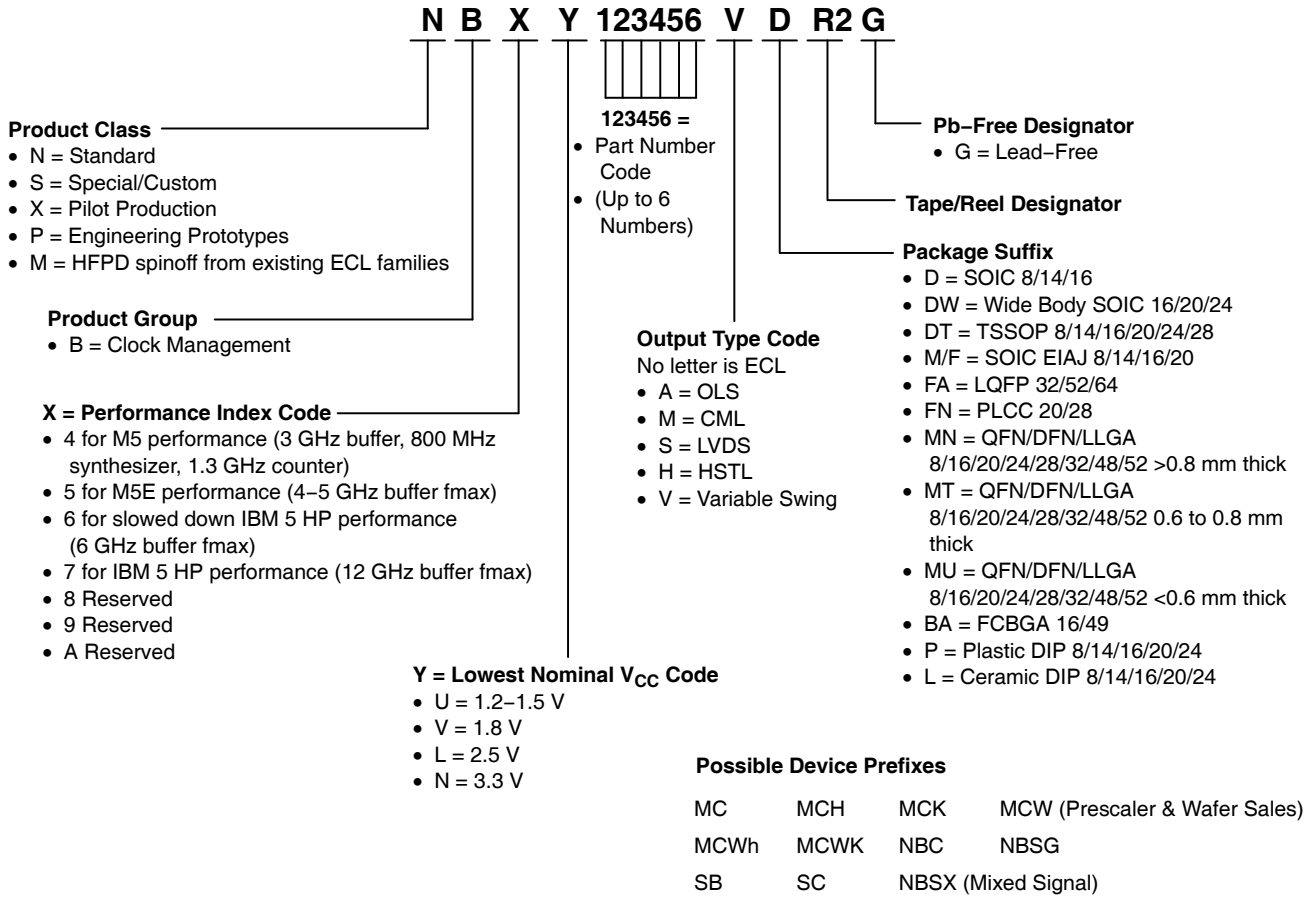

TND310

Naming Convention for Crystal Oscillator Devices

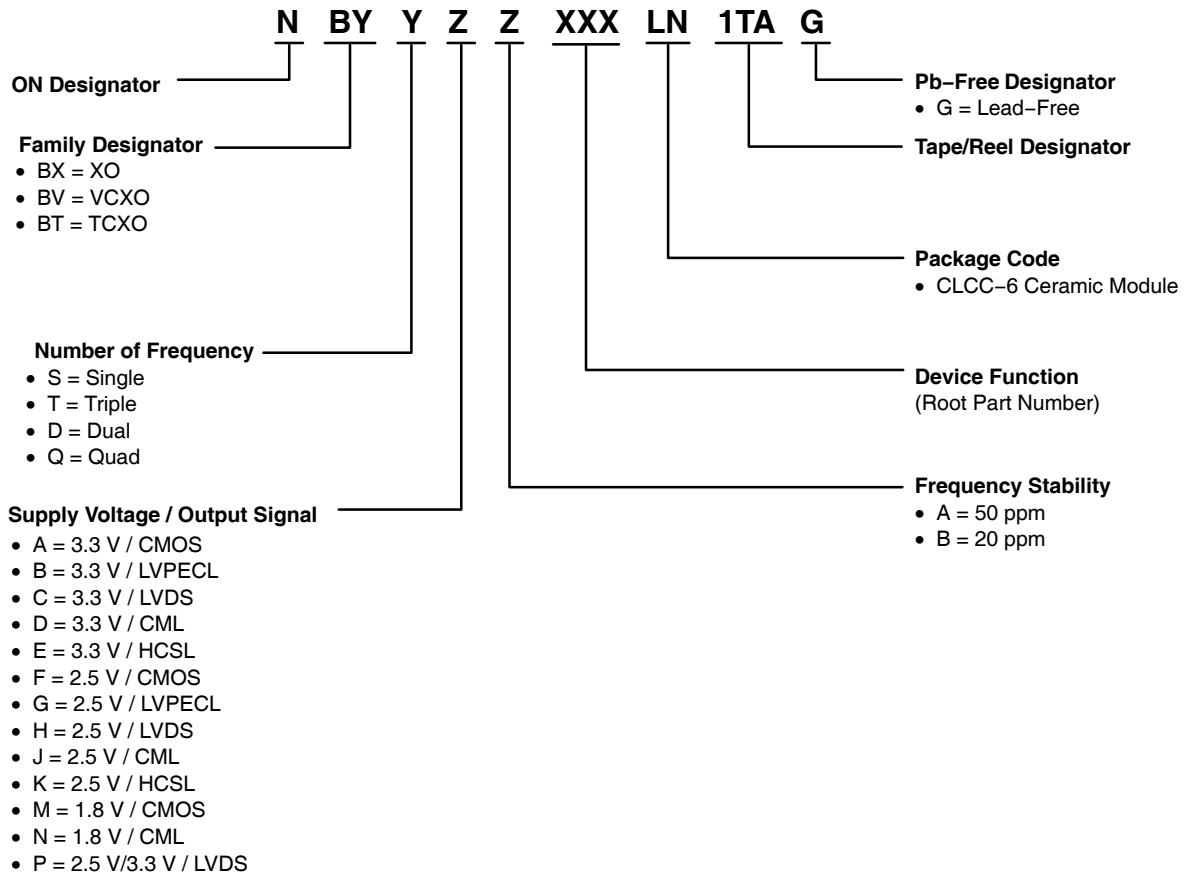

TND310

Naming Convention for Integrated Solutions Devices

N U D 3 1 3 4 X 6 T 1 G

Product Class

- N = Standard
- S = Special/Custom
- X = Pilot Production
- P = Engineering Prototypes

Product Group

- U = MicroIntegration™
- I = Smart

Product Family

- D = Driver
- F = Filter
- P = Protection
- S = Special Function

Descriptor 1

Product Family Description	Symbol
Drivers Legacy	3
LED	4
Filters # of Filters	1-9
Protection # of Protected Lines	1-9
SpecFunct/Customer Special Part No	0-9

Descriptor 2

Product Family Description	Symbol
Driver Function Type	1
Filter Part Number	0-9
Protection Line Type	1
Protection Line Type	2
SpecFunct/Customer Special Part No	0-9

Symbol Symbol Definition

1	Relay
0-9	4 = Audio Filters
1	Data Line Only
2	Data and Power Line
0-9	

Pb-Free Designator

- G = Lead-Free

Tape/Reel Designator

Package Designator

- V = 24 Pin MLF
- H = ChipFET™
- B = D2PAK
- C = DPAK
- - Die T & R
- FC = Flip-Chip
- K = Micro8™
- U = MicroLeadless™
- QP = PLLP
- SN = POWERMITE®
- MN = QFN/DFN: >0.8 mm thick
- MT = QFN/DFN: 0.6 to 0.8 mm thick
- MU = QFN/DFN: <0.6 mm thick
- P5 = SOT953
- P6 = SOT963
- WT = SC70
- T = SC75/SC89
- W1 = SC88
- W5 = SC88A
- A = SMA
- S = SMC
- D = SOIC
- Z = SOT223
- L = SOT23
- XV5 = SOT553
- XV6 = SOT563
- E = SPAK
- M5 = TSOP5
- M = TSOP6/SC74

'D' before pkg designator indicates dual.
 '1' after pkg designator = latch off SMAR only.
 '2' after pkg designator = auto-retry for S products only.

Descriptor 3, 4

Product Family Description	Symbol
Driver Part Number	0-9
Filter Part Number	0-9
Protection Part Number	0-9
SpecFunct/Customer Special	0-9

TND310

Naming Convention for MOS Power Devices

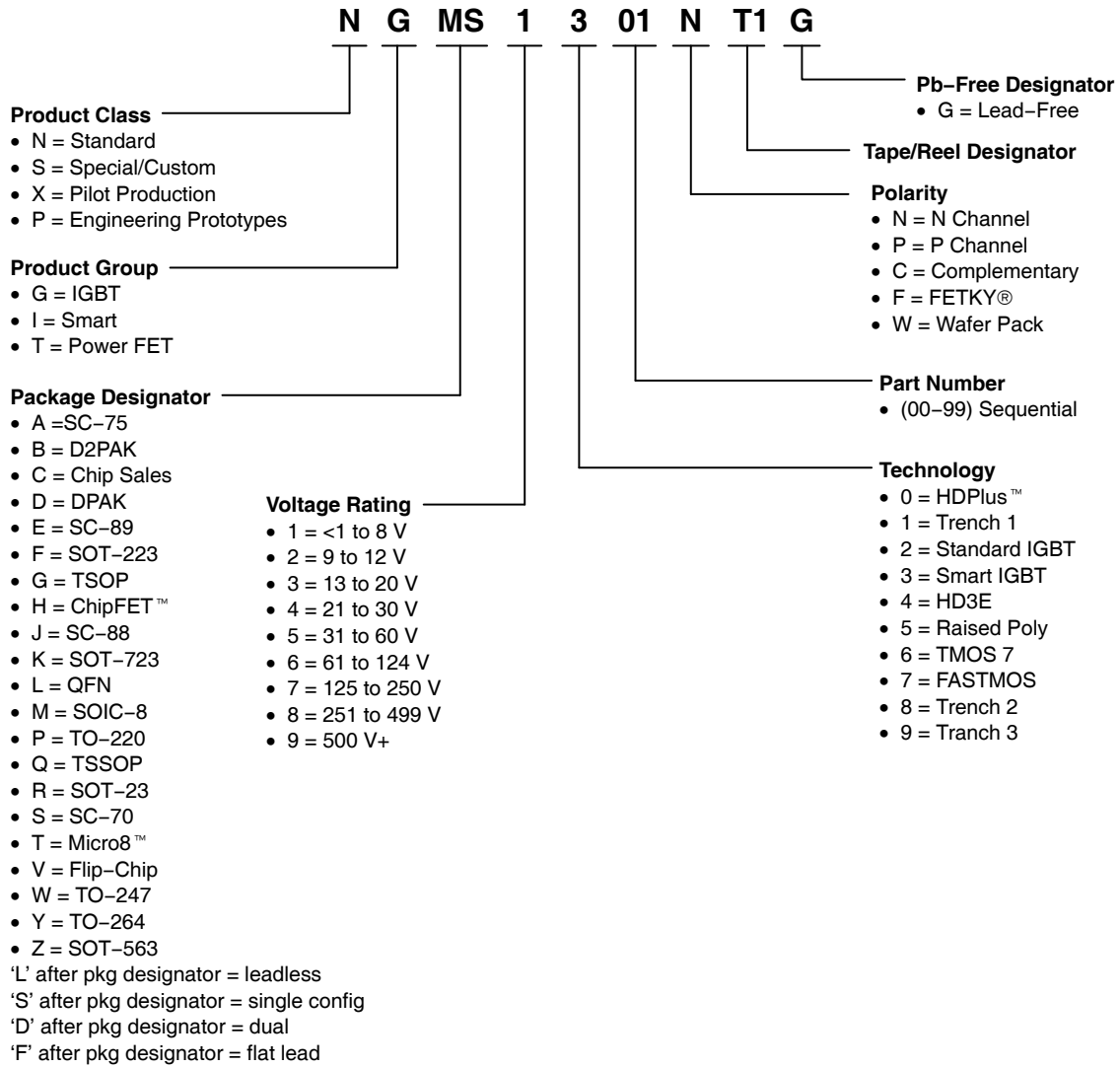

TND310

Naming Convention for SO-8 (MiniMOS™), Micro8™, SOT-223, and TSOP-6 Power MOSFETs

PREVIOUS FORMAT 1

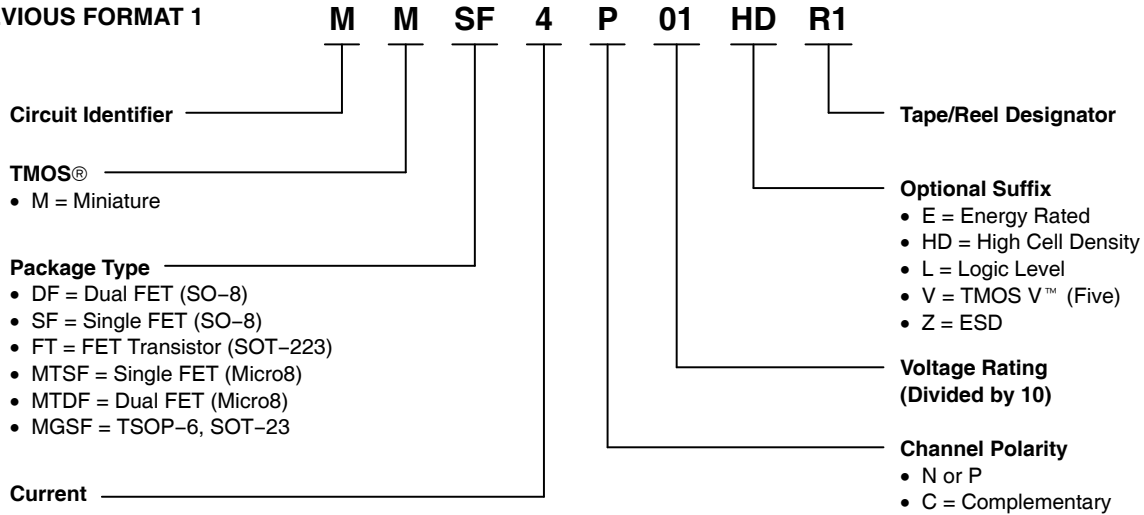

PREVIOUS FORMAT 2

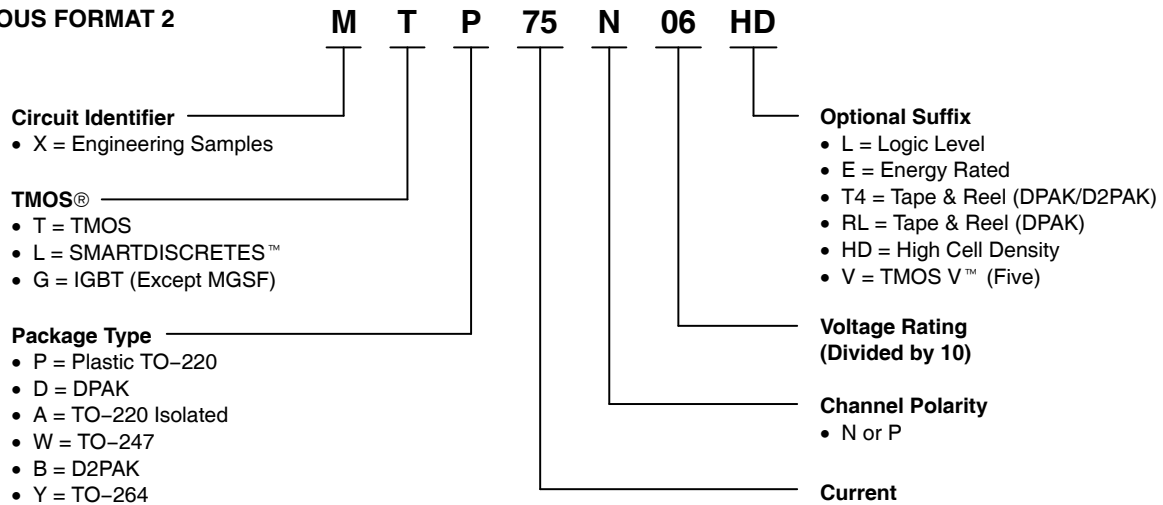

PREVIOUS FORMAT 3

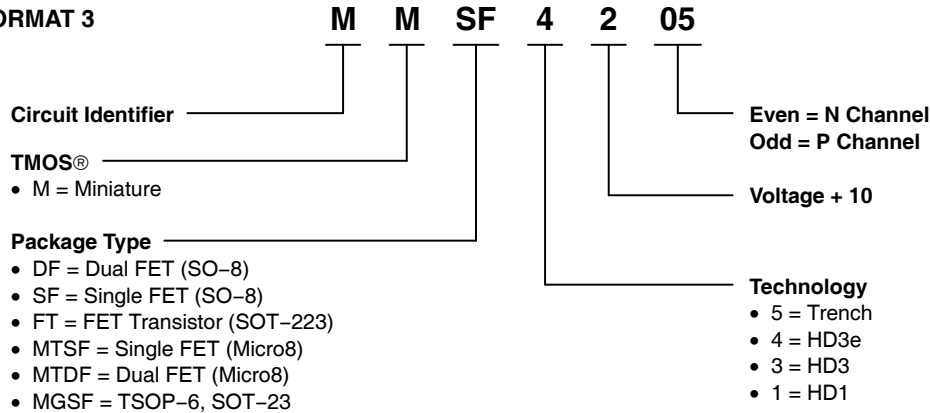

TND310

Naming Convention for Bipolar Power Devices

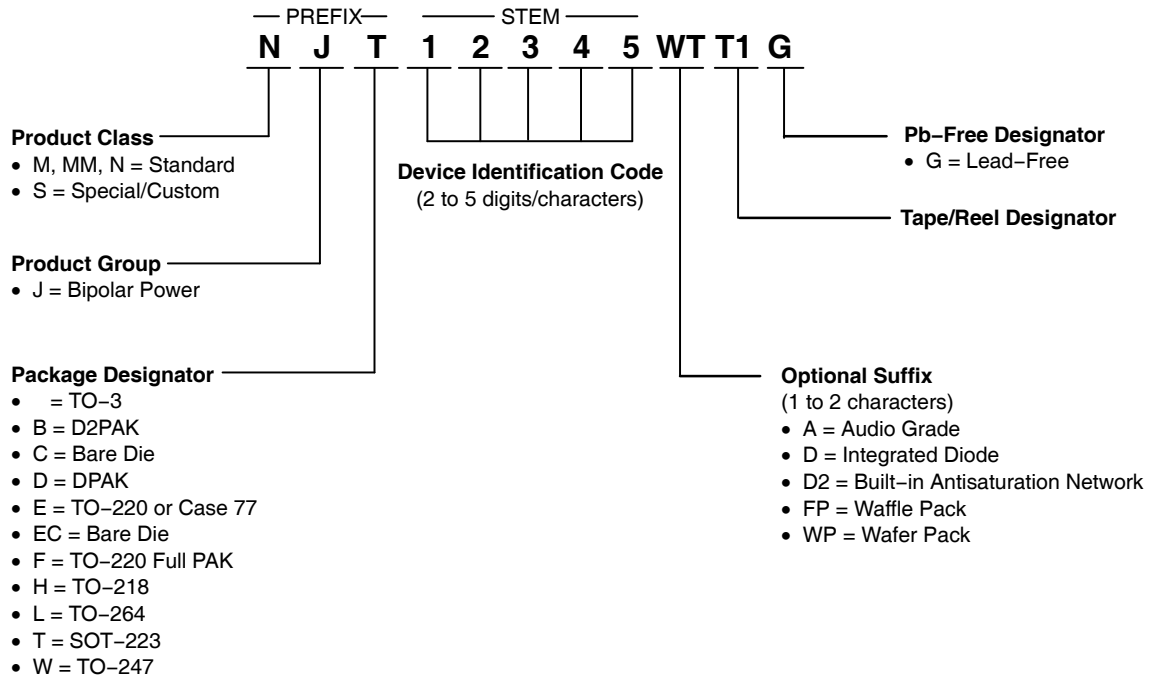

TND310

Naming Convention for Bipolar Power

PREVIOUS FORMAT 1

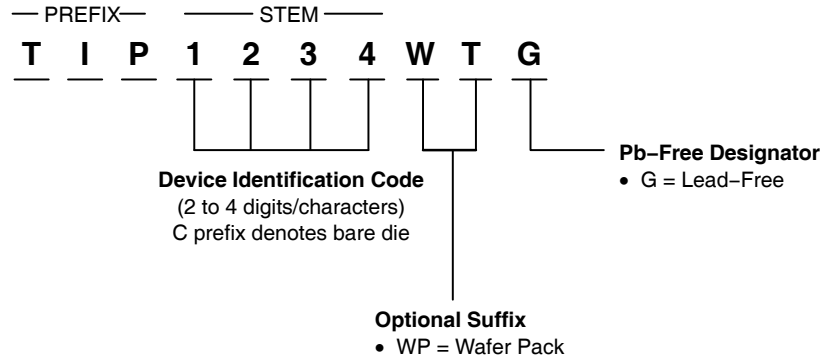

PREVIOUS FORMAT 2

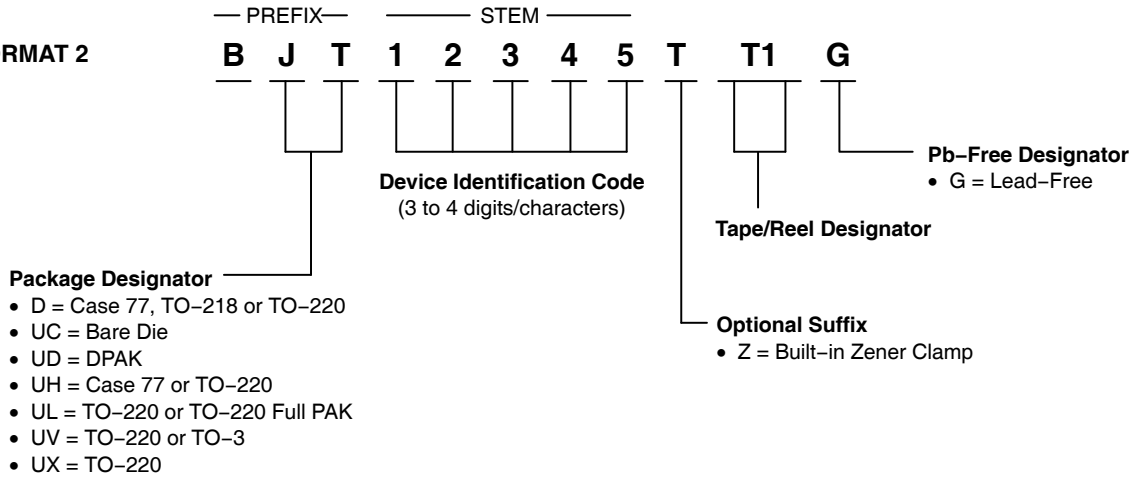

PREVIOUS FORMAT 3

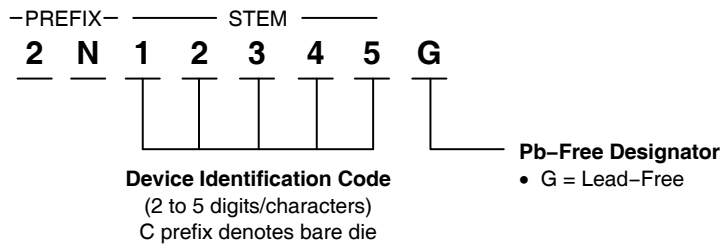

Naming Convention for Rectifier Devices

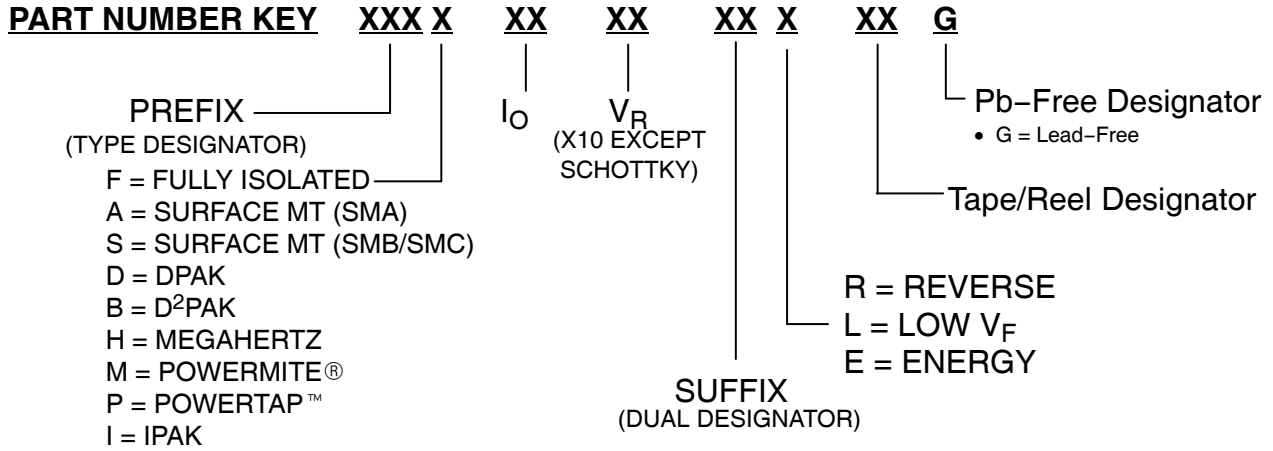

PREFIX KEY

MUR = ULTRA FAST RECTIFIER
 MBR = (SCHOTTKY) BARRIER RECTIFIER
 MR = STANDARD & FAST RECOVERY
 MSR = ULTRASOFT

SUFFIX KEY

CT = CENTER TAP (DUAL) TO-220, POWERTAP, DPAK, D²PAK
 PT = CENTER TAP (DUAL) TO-218 PACKAGE
 WT = CENTER TAP (DUAL) TO-247
 SF = SOD-123 FLAT LEAD
 PF = POWER FACTOR CORRECTION SPECIFIC

EXAMPLE:

MUR	30	20	WT
ULTRAFAST	30 AMP	200 V	CENTER TAP (DUAL) TO-247

EXAMPLE:

MBR	30	45	WT
SCHOTTKY	30 AMP	45 V	CENTER TAP (DUAL) TO-247

TND310

Naming Convention for FMO Bump

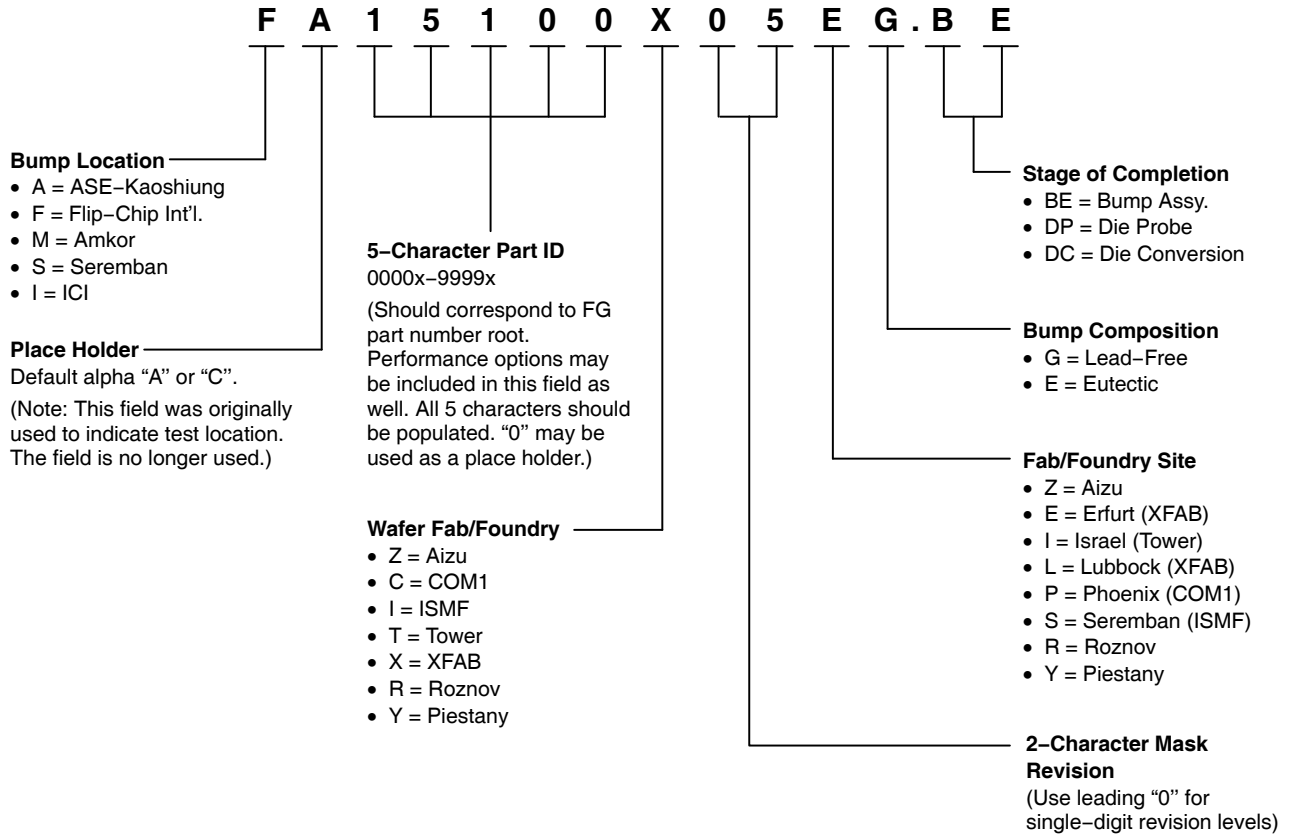

Naming Convention for Ambient Light Sensor Devices

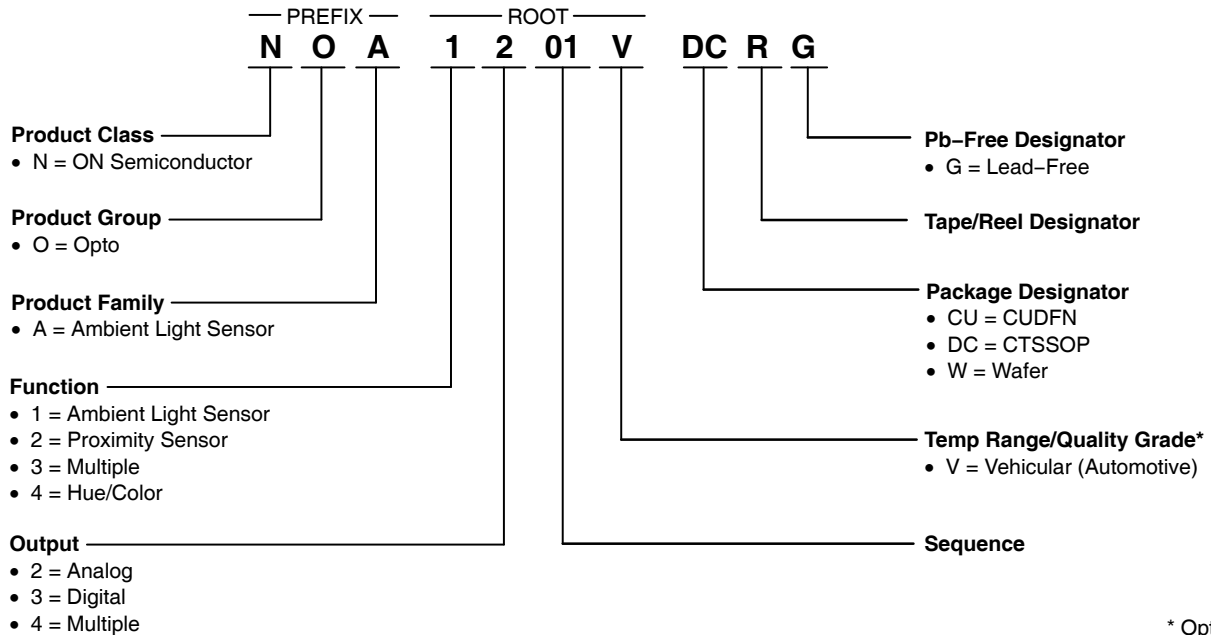

* Optional

TND310

Naming Convention for Contact Image Sensor Devices

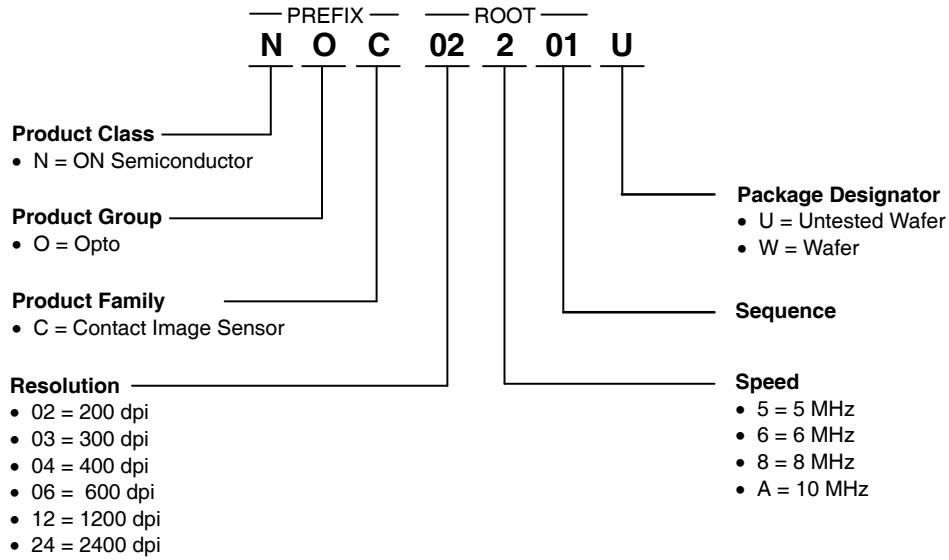

Naming Convention for Contact Image Sensor Modules

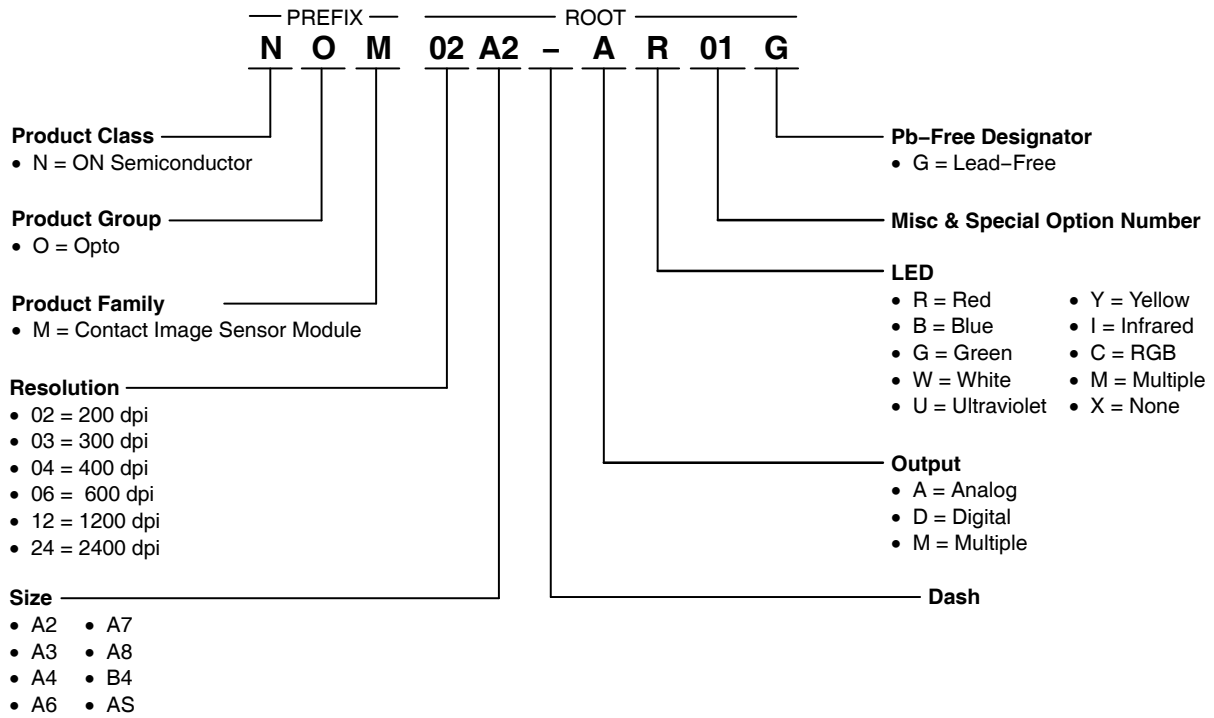

Naming Convention for Photo Diode Array Devices

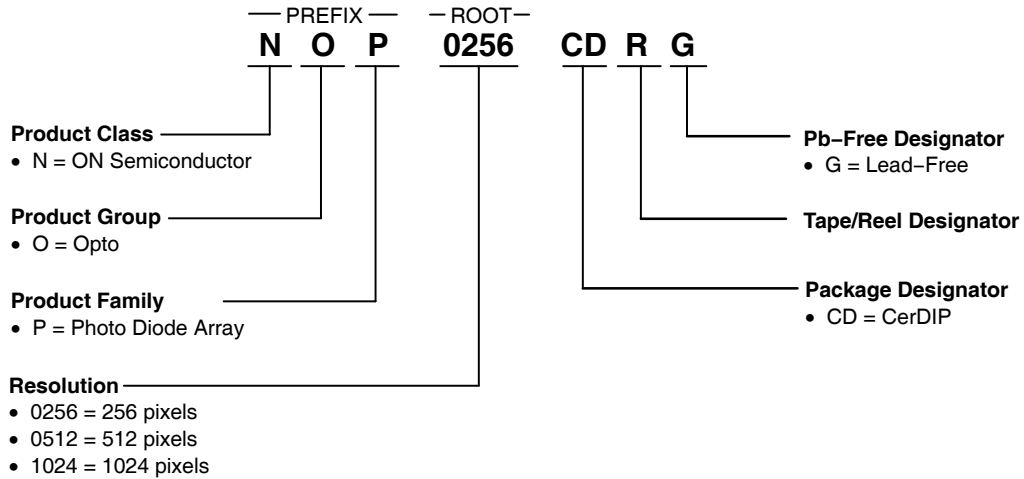

Naming Convention for LED/Lighting Products

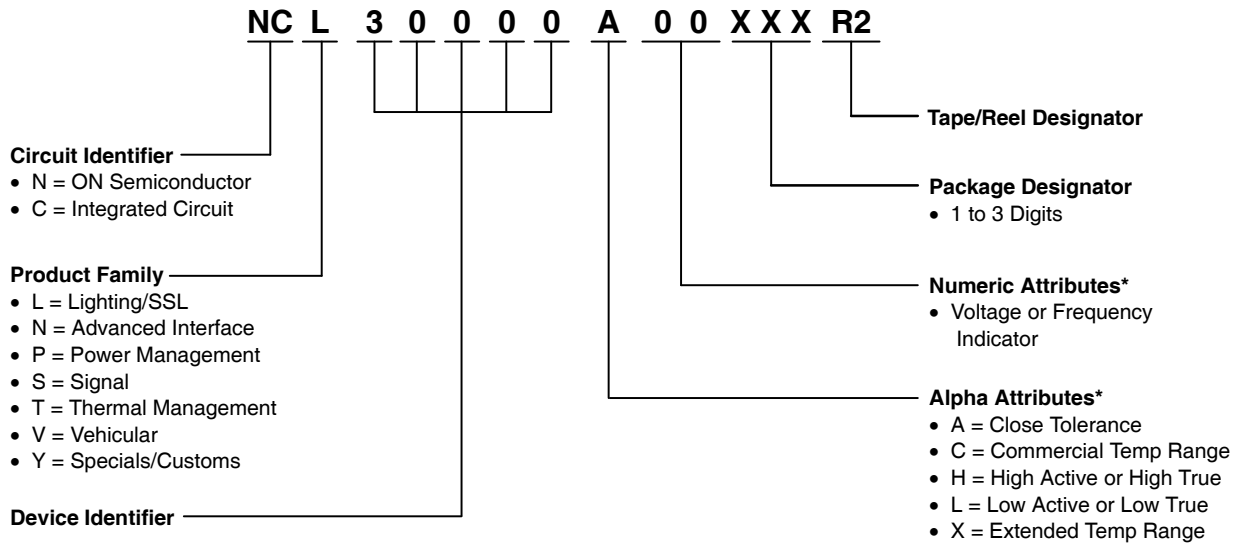

* Optional

TND310

Naming Convention for I²C Serial EEPROMs

(Formerly Catalyst Semiconductor)

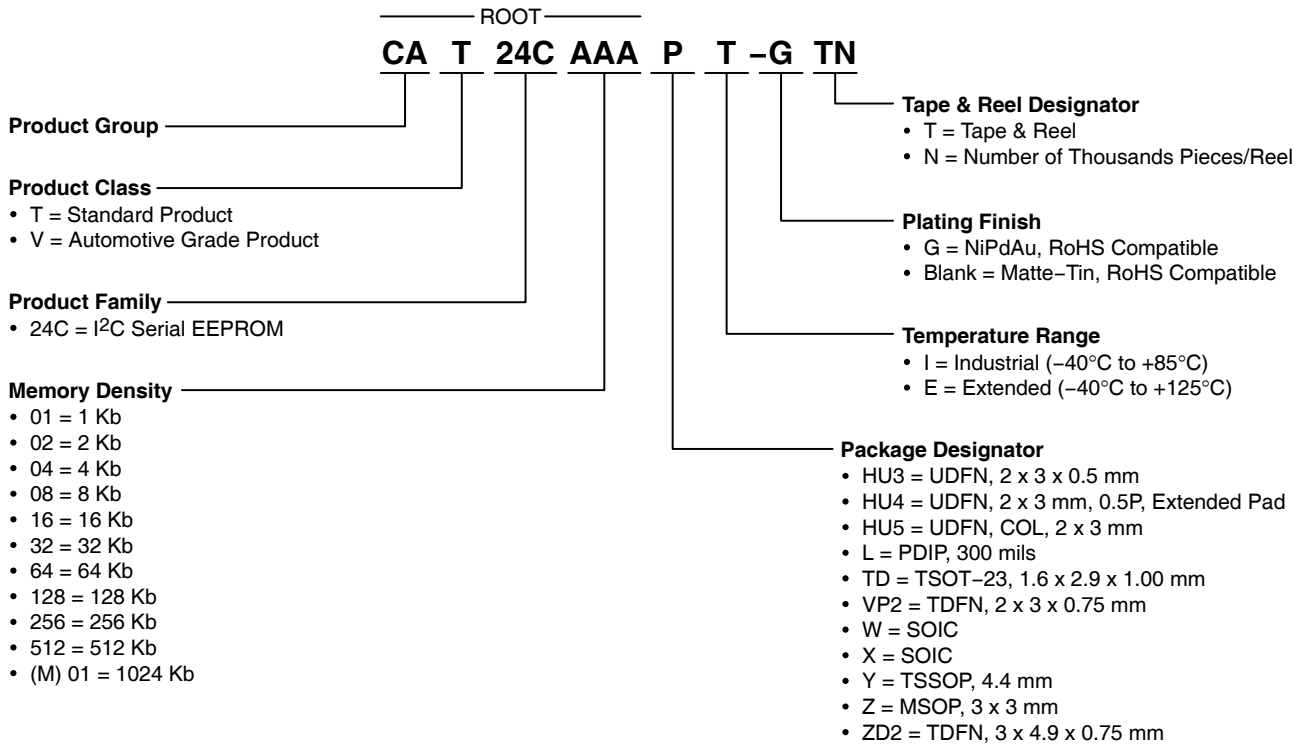

Naming Convention for SPI Serial EEPROMs

(Formerly Catalyst Semiconductor)

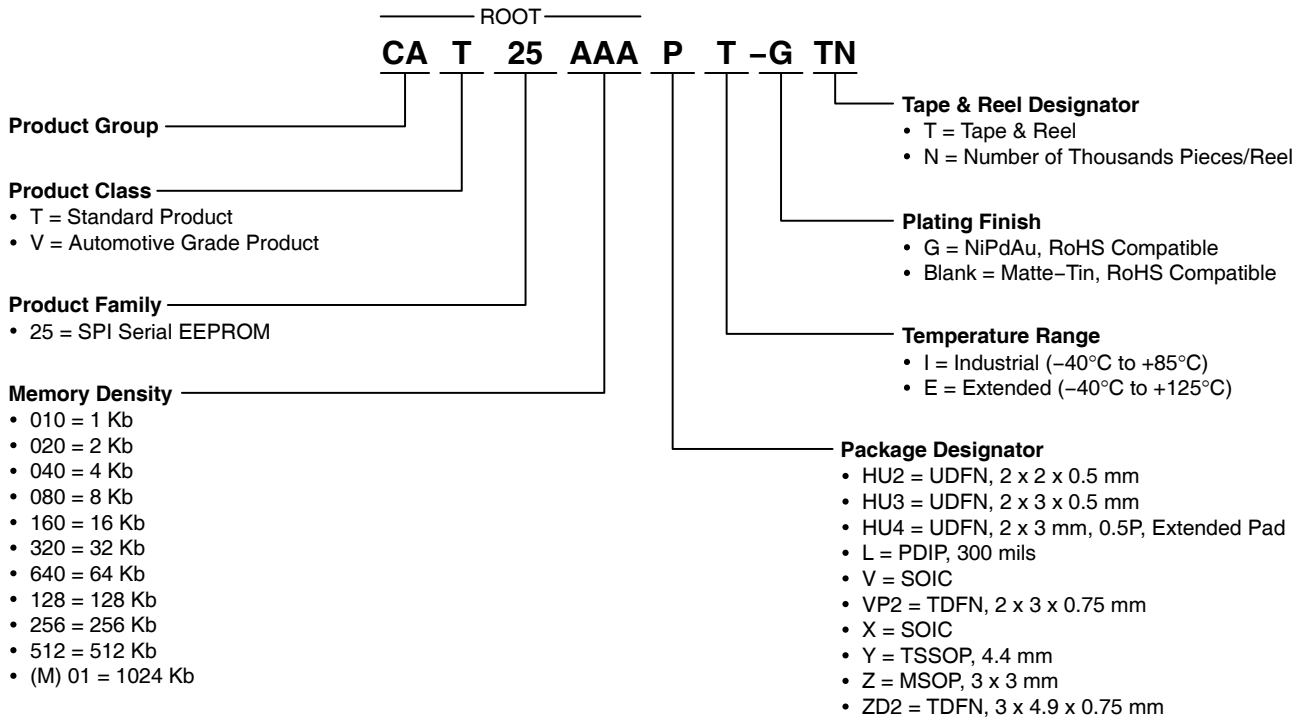

TND310

Naming Convention for Microwire Serial EEPROMs

(Formerly Catalyst Semiconductor)

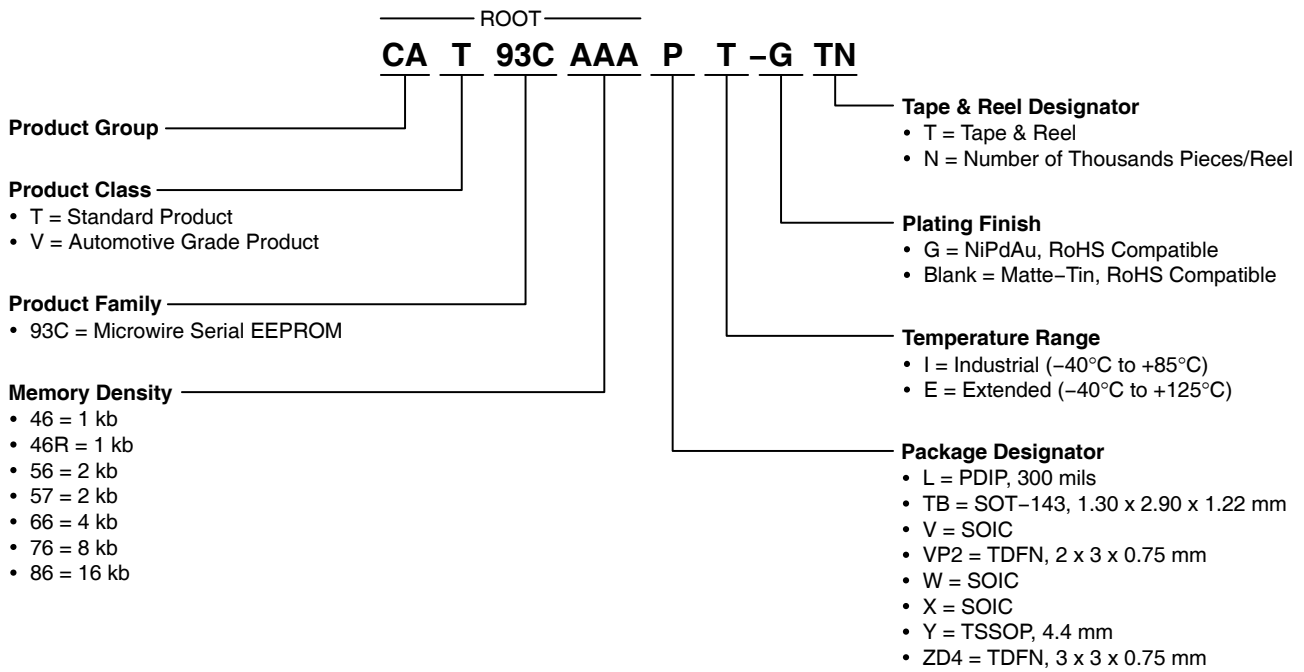

Naming Convention for Low Drop Out (LDO) Products

(Formerly Catalyst Semiconductor)

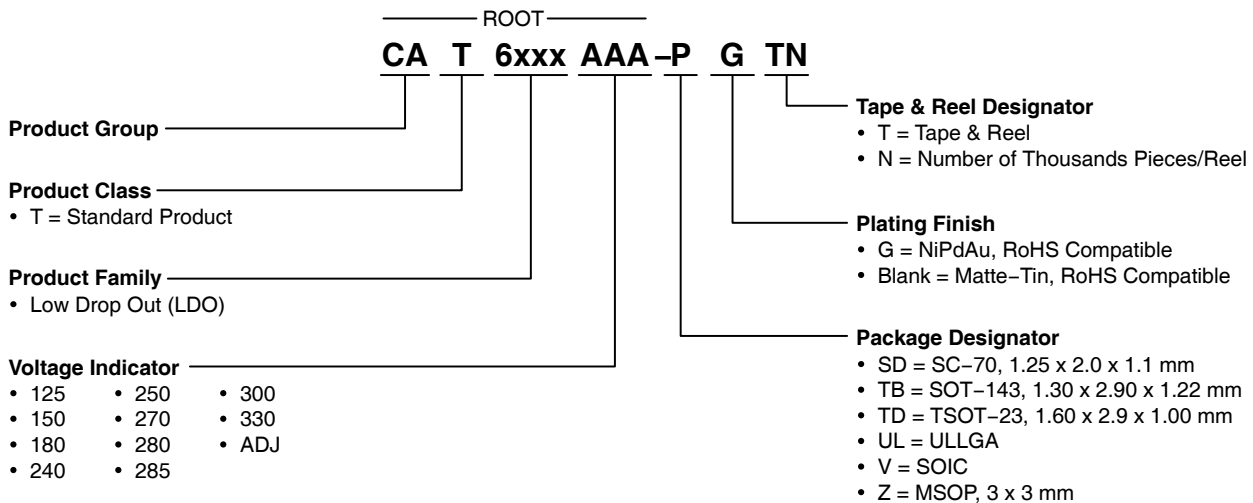

TND310

Naming Convention for Supervisor Products

(Formerly Catalyst Semiconductor)

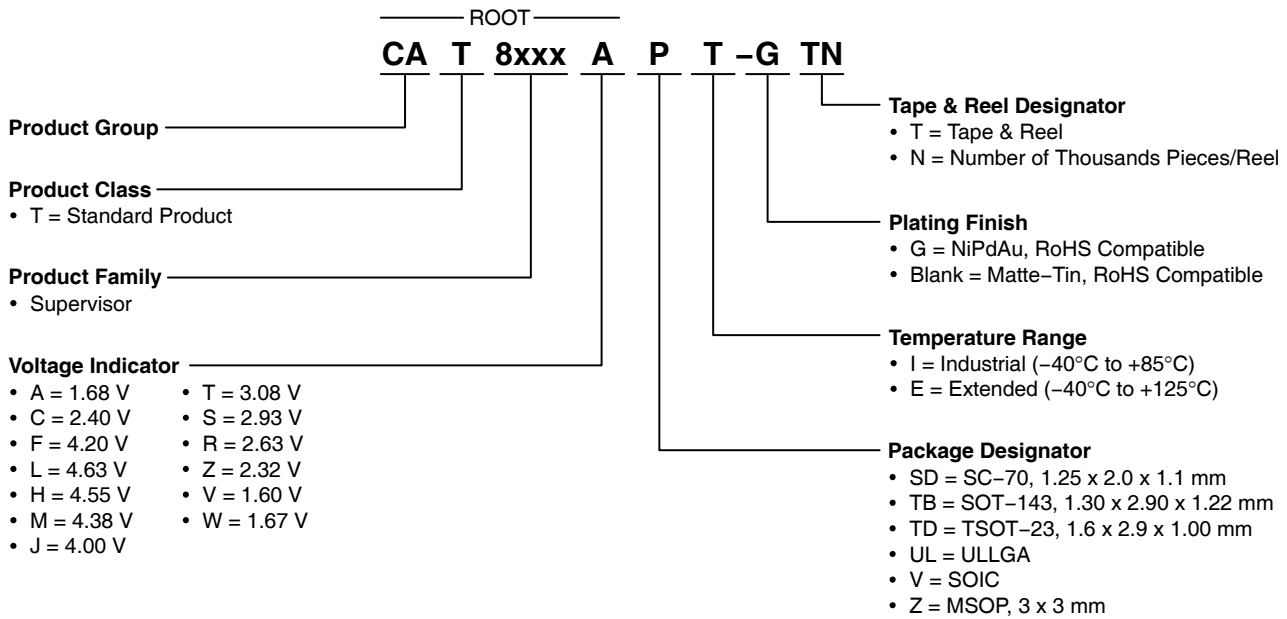

Naming Convention for Charge Pumps, LED Drivers and I/O Bus Products

(Formerly Catalyst Semiconductor)

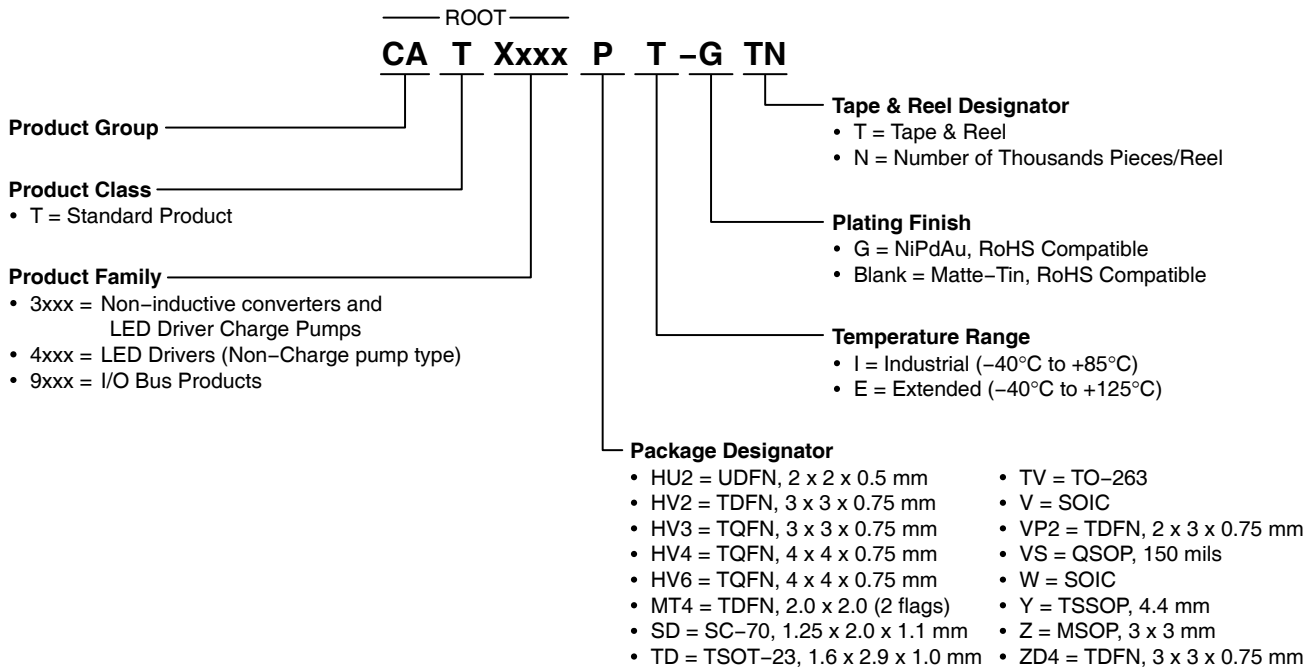

TND310

Naming Convention for Digital Programmable Potentiometers and Supervisor with Memory Products (Formerly Catalyst Semiconductor)

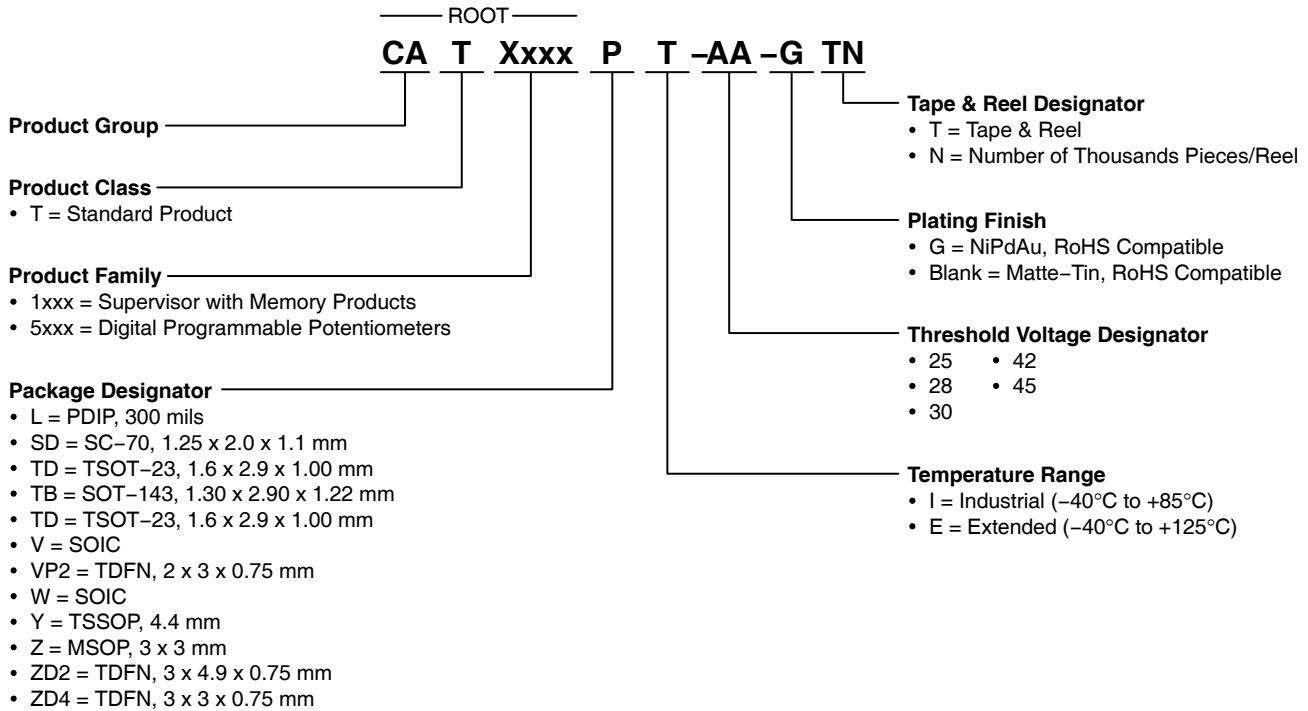

HDPlus, MicroIntegration, MicroLeadless, MiniMOS, POWERMAP, and SMARTDISCRETES are trademarks of Semiconductor Components Industries, LLC (SCILLC).

ChipFET is a trademark of Vishay Siliconix.

FETKY is a registered trademark of International Rectifier Corporation.

Micro8 is a trademark of International Rectifier.

PowerFLEX is a trademark of Texas Instruments Incorporated.

POWERMITE is a registered trademark of and used under a license from Microsemi Corporation.

TMOS V is a trademark of Motorola, Inc.

ON Semiconductor and  are registered trademarks of Semiconductor Components Industries, LLC (SCILLC). SCILLC reserves the right to make changes without further notice to any products herein. SCILLC makes no warranty, representation or guarantee regarding the suitability of its products for any particular purpose, nor does SCILLC assume any liability arising out of the application or use of any product or circuit, and specifically disclaims any and all liability, including without limitation special, consequential or incidental damages. "Typical" parameters which may be provided in SCILLC data sheets and/or specifications can and do vary in different applications and actual performance may vary over time. All operating parameters, including "Typicals" must be validated for each customer application by customer's technical experts. SCILLC does not convey any license under its patent rights nor the rights of others. SCILLC products are not designed, intended, or authorized for use as components in systems intended for surgical implant into the body, or other applications intended to support or sustain life, or for any other application in which the failure of the SCILLC product could create a situation where personal injury or death may occur. Should Buyer purchase or use SCILLC products for any such unintended or unauthorized application, Buyer shall indemnify and hold SCILLC and its officers, employees, subsidiaries, affiliates, and distributors harmless against all claims, costs, damages, and expenses, and reasonable attorney fees arising out of, directly or indirectly, any claim of personal injury or death associated with such unintended or unauthorized use, even if such claim alleges that SCILLC was negligent regarding the design or manufacture of the part. SCILLC is an Equal Opportunity/Affirmative Action Employer. This literature is subject to all applicable copyright laws and is not for resale in any manner.

PUBLICATION ORDERING INFORMATION

LITERATURE FULFILLMENT:

Literature Distribution Center for ON Semiconductor
 P.O. Box 61312, Phoenix, Arizona 85082-1312 USA
Phone: 480-829-7710 or 800-344-3860 Toll Free USA/Canada
Fax: 480-829-7709 or 800-344-3867 Toll Free USA/Canada
Email: orderlit@onsemi.com

N. American Technical Support: 800-282-9855 Toll Free
 USA/Canada

Japan: ON Semiconductor, Japan Customer Focus Center
 2-9-1 Kamimeguro, Meguro-ku, Tokyo, Japan 153-0051
Phone: 81-3-5773-3850

ON Semiconductor Website: <http://onsemi.com>

Order Literature: <http://www.onsemi.com/litorder>

For additional information, please contact your local Sales Representative.