

The NIV3071 eFuse Advantages in Automotive Applications

AND90247/D

Introduction

The electrification in automobiles has driven the replacement of mechanical relays and melting fuses with electronic fuses “eFuses” to enable more compact and efficient solutions. The NIV3071 eFuse protects downstream circuitry from overcurrent, overtemperature and short to ground events, and can provide a fault indicator with the open drain FAULT pin. This device has four integrated high side channels, which can be controlled independently with the EN pins or paralleled together for larger loads. The device has both a configurable current limit and turn-on time, allowing for a wide variety of loads.

NIV3071 in Automotive Applications

There are several advantages to using the NIV3071 in automotive applications. The device is in a 6x5 mm package, greatly reducing the board area needed when compared traditional solutions such as mechanical relays and melting fuses. In comparison to these traditional solutions the eFuse

does not need to be replaced in the event of a fault as its protection features will protect both the device and the load, enabling a distributed zonal architecture throughout the vehicle. There are two versions of this device, latching and auto-retry. In the event of a fault, a latching device will latch off until a command is sent by toggling the EN pin or power cycling. An auto-retry device will wait either 3 ms or if entering the thermal shutdown protection enough time to cool the die down before attempting to turn back on.

Another advantage over traditional fuses is the NIV3071 has a very fast short circuit response time of 6 μs in the event of a fault. This severely reduces the peak current and power dissipation when compared to traditional fuses as seen in Figure 1, which benefits the peak current and power rating of any associated wire harness. Additionally, the quick response time prevents the input power supply from sagging, which will protect any safety critical and other loads that are using the same power supply as illustrated in Figure 2.

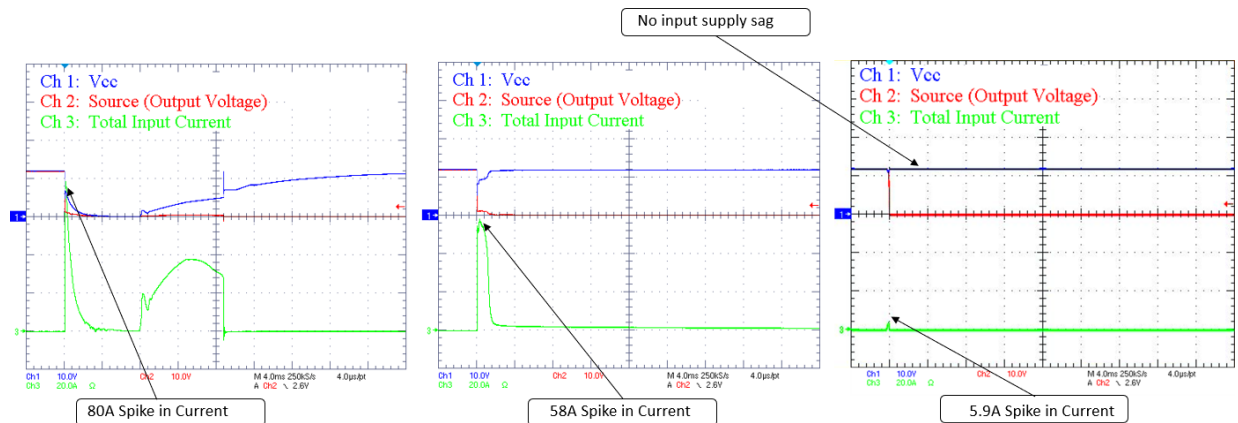

Figure 1. Left Blade Fuse, Center PTC, Right NIV3071 eFuse

AND90247/D

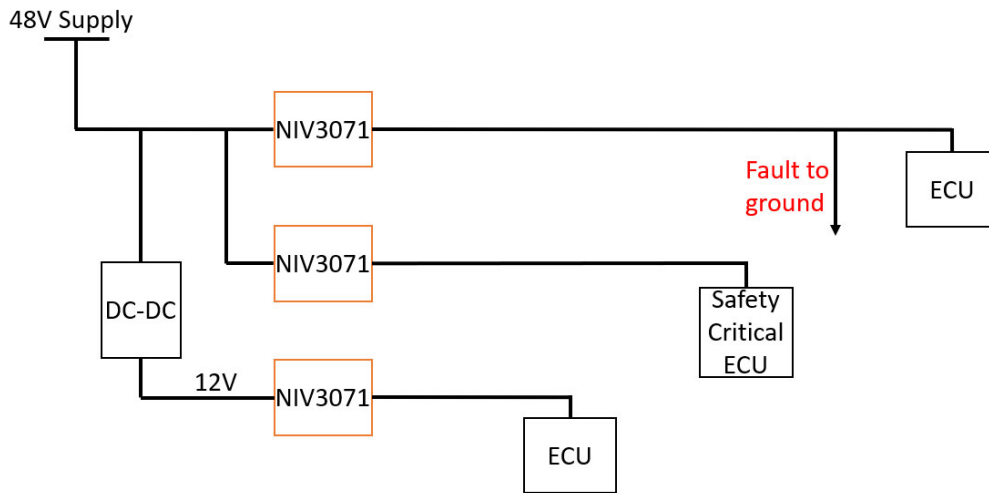

Figure 2. Multiple eFuses on the same Power Supply

The NIV3071 is made up of four integrated channels which can be driven either independently or paralleled together to supply more load current, described in Figure 3. The inputs can be powered by different supplies or a common supply. With this flexibility, the NIV3071 can

easily support both 48 V and 12 V loads through the same device. This is extremely beneficial in automotive applications, where the presence of 48 V and 12 V loads in an ECU (electronic control unit) could be protected through one device.

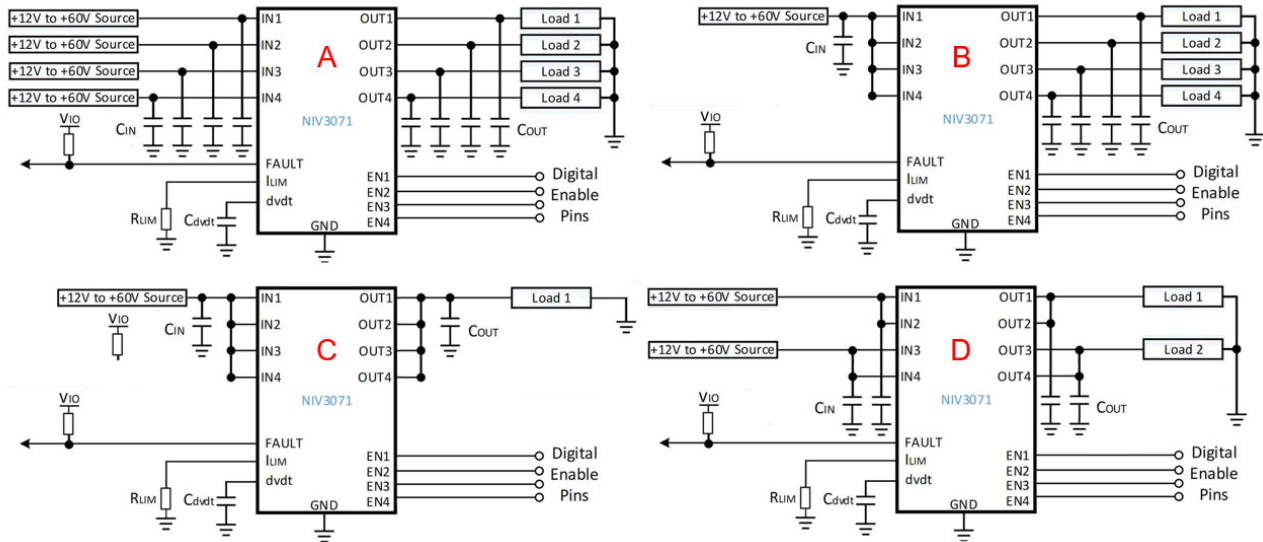

Figure 3. Configurations of the NIV3071

This device is intended to be used with regulated power supplies. Other automotive applications where cold crank

and load dump are required are not recommended due to the UVLO and lack of reverse current protection on this device.

Dynamic Features and Considerations

Turn-on Timing

The NIV3071 has a controlled turn on which can be described by the On Delay Time ($t_{DLY(On)}$) and Turn-on Time ($t_{RAMP(On)}$), seen in Figure 4:

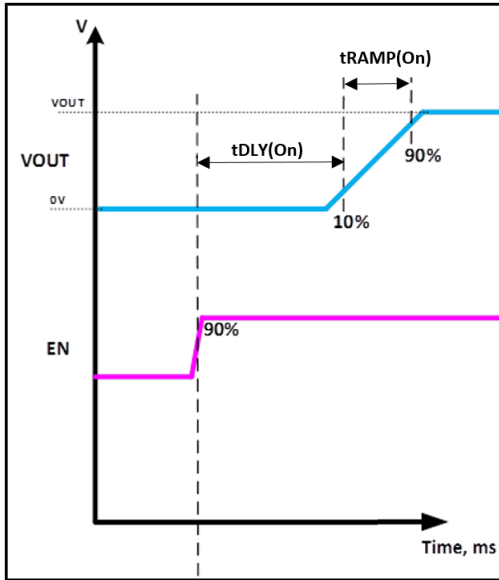

Figure 4. Turn-on Timing of the NIV3071

The On Delay Time is defined as the time between the EN pin reaching 90% of its maximum value to 10% of the nominal voltage on the output. The Turn-on Time is defined as the time between 10% to 90% of the nominal voltage on the output. The On Delay Time is used as a deglitch filter in

the event of any momentary voltage spike on the EN pin or if the microcontroller has a small delay when powering up in sending the correct logic signal, ensuring a safe start into the load at the time it is designed to be engaged.

The Turn-on Time feature can be configured by an external capacitor. To properly use the Turn-on Time feature the type of load must be considered. While there is a benefit to increasing the Turn-on Time for capacitive loads by reducing the inrush current spike, a resistive load will draw a continuous increasing current as the output is rising. From this dc current and the prolonged output Turn-on Time in which creates a voltage gradient across the device, the device will dissipate a large amount of power and potentially enter thermal shutdown to protect the die before the device can fully turn on. This will be dependent on the input voltage, output voltage Turn-on Time, load current profile and ambient temperature.

Inrush Current Control

The NIV3071 and other eFuse’s at **onsemi** have an inrush current control feature to limit the peak current seen when turning on capacitive loads. This feature is governed by an external pin which can be left open or with a low value ceramic capacitor between the dvdt pin and ground. By adding capacitance to this pin, the output Turn-on Time is elongated which allows for lower peak currents, which can be expressed by:

$$I_{peak} = C_{load} \frac{dv_{out}}{dt}$$

The following relation can be used to control the peak current with a given C_{load} :

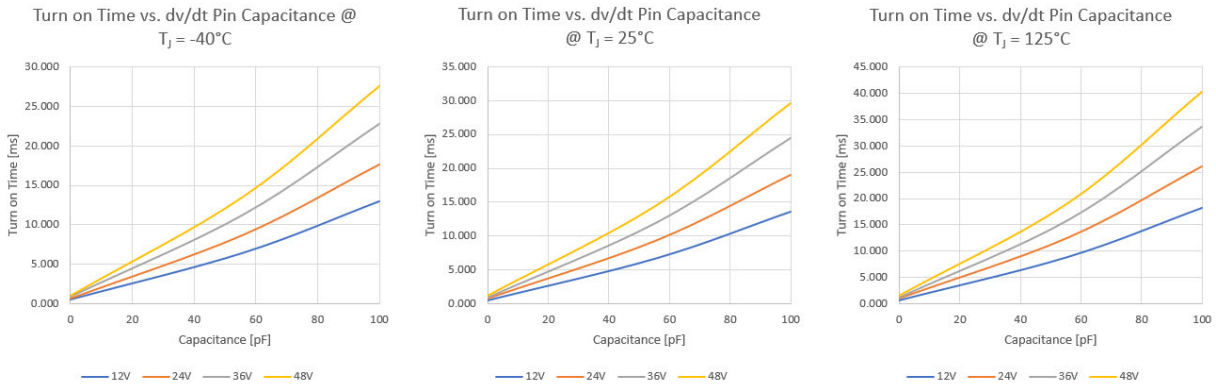
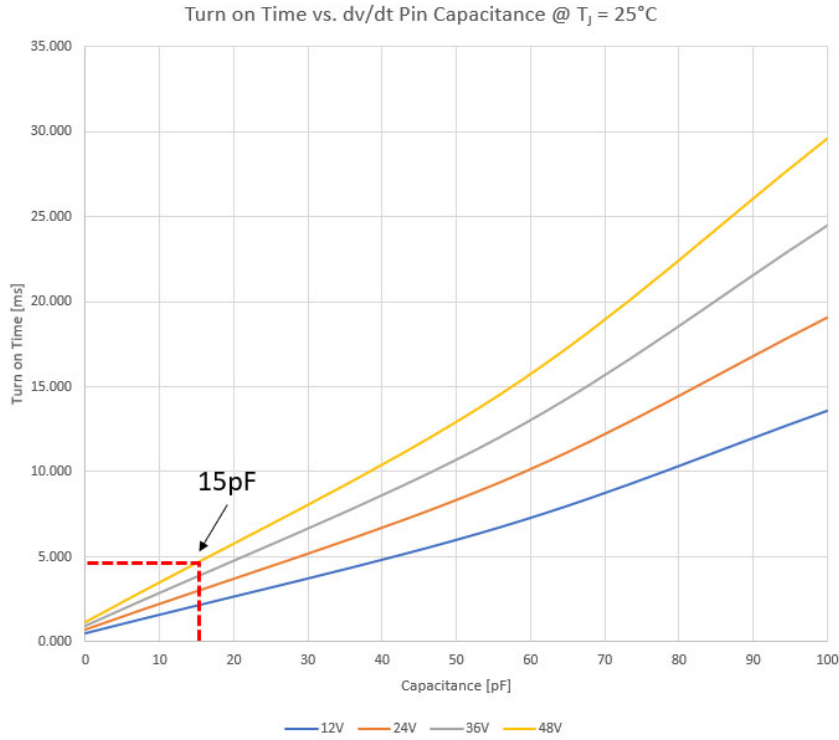

Figure 5. Turn-on Time vs dv/dt Pin Capacitance

Using above equation and Figure 5., the user can set a max inrush current when turning on into a capacitive load. A test case is provided below in Figures 6 and 7:

AND90247/D



Conditions:

- T_{ambient} = 25°C
- V_{in} = 48V
- C_{load} = 100μF
- R_{load} = 2kΩ
- C_{dv/dt} = 15pF
- R_{lim} = 30kΩ
- I_{peak} = 1A

$$I_{peak} = C_{load} \frac{dv_{out}}{dt}$$

$$dt = \frac{C_{load} dv_{out}}{I_{peak}} = 4.8ms$$

Figure 6. Test Case for Inrush Current Control

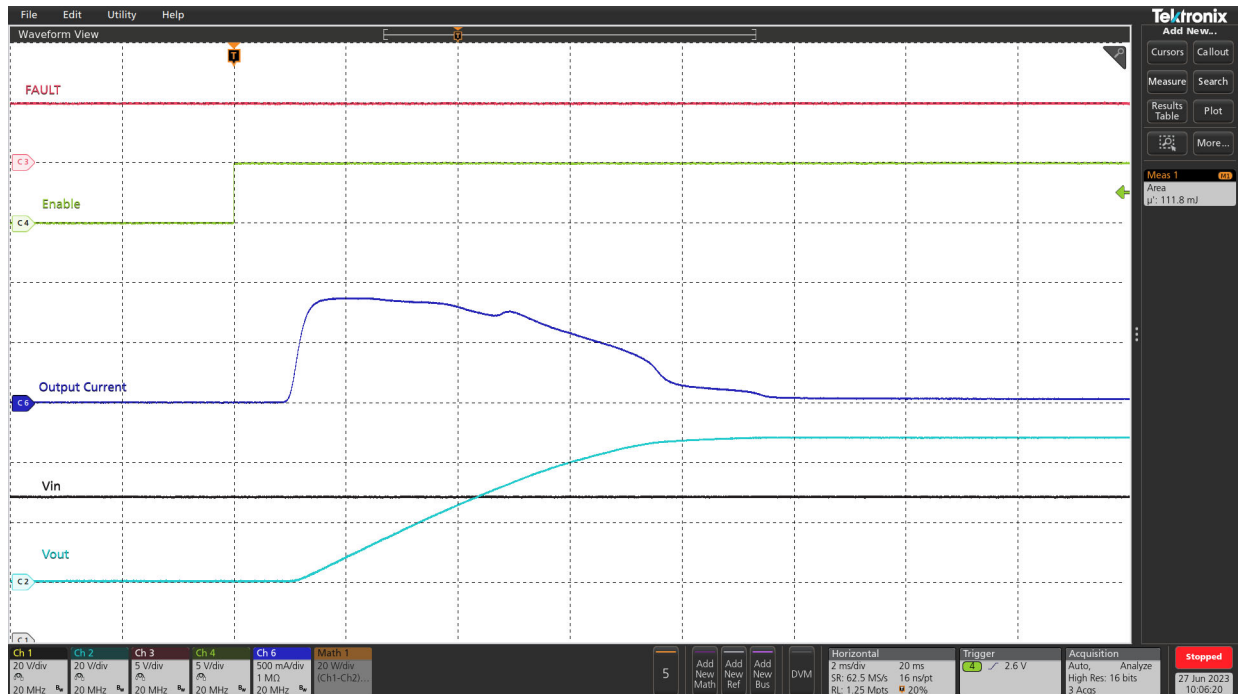

Figure 7. Measured Result from Test Case

AND90247/D

Large Capacitive Loads and Schottky

With larger capacitive loads (and low current DC loads), a Schottky diode can be placed from output to input as seen in Figure 8. to protect the body diode of eFuse against excessive reverse current when powering down the device. Once the input voltage falls below UVLO the device will

turn off, creating a reverse voltage across the device as the output capacitor maintains the voltage on the output before fully discharging. The negative voltage at the same time biases the Schottky, providing a path to discharge around the device as seen in the measurement in Figure 9.

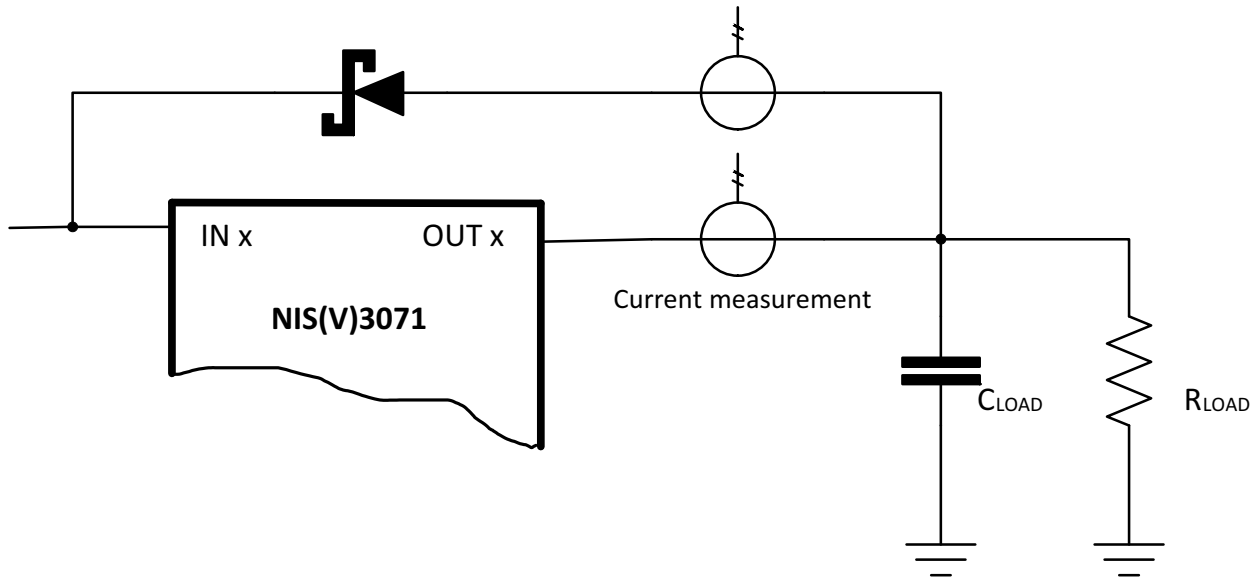

Figure 8. Using a Schottky to Protect Against Reverse Current Conditions

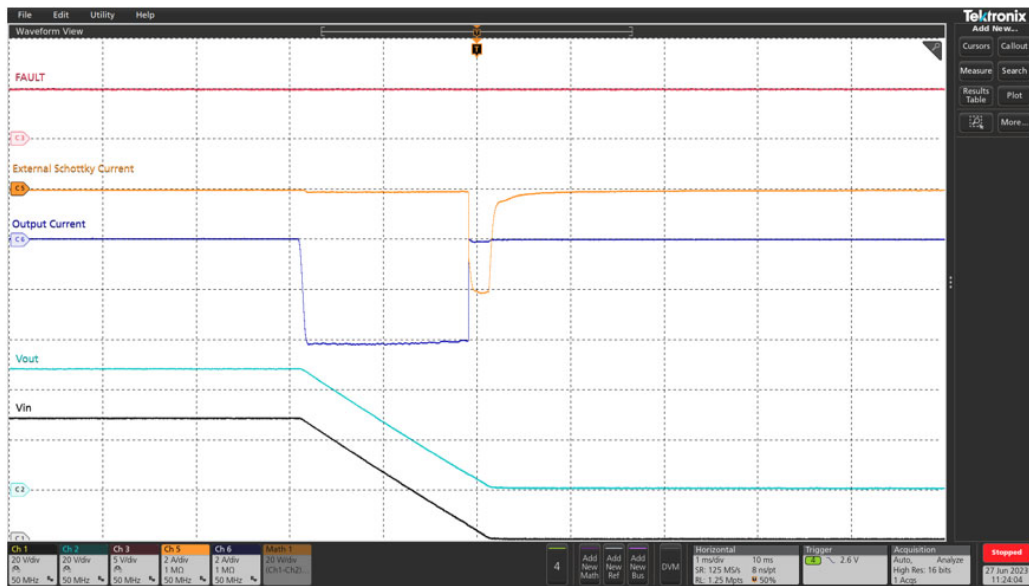

Figure 9. Measurement of Current through the Device and through the External Schottky Diode

AND90247/D

Switching Off with Inductive Loading

During a short to ground or overcurrent fault event on the output, the NIV3071 is designed to quickly turn off to protect both device and downstream circuitry. If there are significant inductances in the power path, such as cabling, the quick turn off will result in voltage spikes that can exceed the devices voltage ratings. To mitigate these voltage spikes several options can be used. A TVS diode could be placed between the input and ground, while a Schottky diode can be placed in parallel with the load as a freewheeling diode.

Additionally, a RC snubber circuit can be used in parallel with load. If the application has an expected inductance over 5 uH, an external Schottky or snubber is highly recommended.

Summary

The NIV3071 has many advantages in automotive applications as the trend of electrification trends and the prevalence of 48 V systems continues to increase in the automotive markets.

onsemi, **Onsemi**, and other names, marks, and brands are registered and/or common law trademarks of Semiconductor Components Industries, LLC dba "**onsemi**" or its affiliates and/or subsidiaries in the United States and/or other countries. **onsemi** owns the rights to a number of patents, trademarks, copyrights, trade secrets, and other intellectual property. A listing of **onsemi**'s product/patent coverage may be accessed at www.onsemi.com/site/pdf/Patent-Marking.pdf. **onsemi** reserves the right to make changes at any time to any products or information herein, without notice. The information herein is provided "as-is" and **onsemi** makes no warranty, representation or guarantee regarding the accuracy of the information, product features, availability, functionality, or suitability of its products for any particular purpose, nor does **onsemi** assume any liability arising out of the application or use of any product or circuit, and specifically disclaims any and all liability, including without limitation special, consequential or incidental damages. Buyer is responsible for its products and applications using **onsemi** products, including compliance with all laws, regulations and safety requirements or standards, regardless of any support or applications information provided by **onsemi**. "Typical" parameters which may be provided in **onsemi** data sheets and/or specifications can and do vary in different applications and actual performance may vary over time. All operating parameters, including "Typicals" must be validated for each customer application by customer's technical experts. **onsemi** does not convey any license under any of its intellectual property rights nor the rights of others. **onsemi** products are not designed, intended, or authorized for use as a critical component in life support systems or any FDA Class 3 medical devices or medical devices with a same or similar classification in a foreign jurisdiction or any devices intended for implantation in the human body. Should Buyer purchase or use **onsemi** products for any such unintended or unauthorized application, Buyer shall indemnify and hold **onsemi** and its officers, employees, subsidiaries, affiliates, and distributors harmless against all claims, costs, damages, and expenses, and reasonable attorney fees arising out of, directly or indirectly, any claim of personal injury or death associated with such unintended or unauthorized use, even if such claim alleges that **onsemi** was negligent regarding the design or manufacture of the part. **onsemi** is an Equal Opportunity/Affirmative Action Employer. This literature is subject to all applicable copyright laws and is not for resale in any manner.

ADDITIONAL INFORMATION

TECHNICAL PUBLICATIONS:

Technical Library: www.onsemi.com/design/resources/technical-documentation
onsemi Website: www.onsemi.com

ONLINE SUPPORT: www.onsemi.com/support

For additional information, please contact your local Sales Representative at www.onsemi.com/support/sales