



ON Semiconductor®

FGH75T65SHD

650 V, 75 A 场截止沟槽 IGBT

特性

- 最大结温: $T_J = 175^\circ\text{C}$
- 正温度系数, 易于并联运行
- 高电流能力
- 低饱和电压: $V_{CE(sat)} = 1.6\text{ V}$ (典型值) @ $I_C = 75\text{ A}$
- 器件 100% 经过 $I_{LM}(1)$ 测试
- 高输入阻抗
- 快速开关
- 紧密的参数分布
- 符合 RoHS 标准

概述

ON Semiconductor 场截止第三代 IGBT 新系列采用创新型场截止 IGBT 技术, 为光伏逆变器、UPS、焊机、通讯、ESS 和 PFC 等低导通和开关损耗至关重要的应用提供最佳性能。

应用

- 太阳能逆变器、UPS、电焊机、电信、ESS、PFC

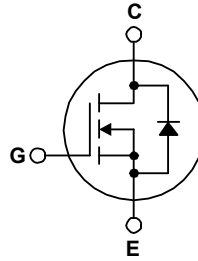
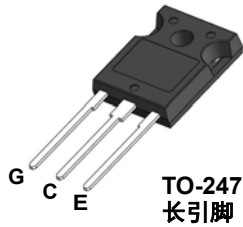

绝对最大额定值 $T_C = 25^\circ\text{C}$ 除非另有说明

符号	描述	FGH75T65SHD-F155	单位
V_{CES}	集电极-发射极之间电压	650	V
V_{GES}	栅极-发射极间电压	± 20	V
	瞬态栅极-发射极间电压	± 30	V
I_C	集电极电流 @ $T_C = 25^\circ\text{C}$	150	A
	集电极电流 @ $T_C = 100^\circ\text{C}$	75	A
$I_{LM}(1)$	集电极脉冲电流 @ $T_C = 25^\circ\text{C}$	225	A
$I_{CM}(2)$	集电极脉冲电流	225	A
I_F	二极管正向电流 @ $T_C = 25^\circ\text{C}$	75	A
	二极管正向电流 @ $T_C = 100^\circ\text{C}$	50	A
$I_{FM}(2)$	二极管最大正向脉冲电流	225	A
P_D	最大功耗 @ $T_C = 25^\circ\text{C}$	455	W
	最大功耗 @ $T_C = 100^\circ\text{C}$	227	W
T_J	工作结温	-55 至 +175	$^\circ\text{C}$
T_{stg}	存储温度范围	-55 至 +175	$^\circ\text{C}$
T_L	用于焊接的最大引脚温度, 距离外壳 1/8", 持续 5 秒	300	$^\circ\text{C}$

注:

1. $V_{CC} = 400\text{ V}$, $V_{GE} = 15\text{ V}$, $I_C = 225\text{ A}$, $R_G = 20\ \Omega$, 电感负载
2. 重复额定值: 脉宽受最大结温限制

热性能

符号	参数	FGH75T65SHD-F155	单位
$R_{\theta JC}$ (IGBT)	结至外壳热阻最大值	0.33	$^{\circ}\text{C}/\text{W}$
$R_{\theta JC}$ (Diode)	结至外壳热阻最大值	0.65	$^{\circ}\text{C}/\text{W}$
$R_{\theta JA}$	结至环境热阻最大值	40	$^{\circ}\text{C}/\text{W}$

封装标识与订购信息

器件编号	顶标	封装	包装方法	卷尺寸	带宽	每管数量
FGH75T65SHD-F155	FGH75T65SHD	TO-247 G03	塑料管	-	-	30

IGBT 电气特性 $T_C = 25^{\circ}\text{C}$ 除非另有说明

符号	参数	测试条件	最小值	典型值	最大值	单位
关断特性						
BV_{CES}	集电极-发射极击穿电压	$V_{GE} = 0\text{ V}, I_C = 1\text{ mA}$	650	-	-	V
$\Delta BV_{CES} / \Delta T_J$	击穿电压温度系数电压	$I_C = 1\text{ mA}$, 参考 25°C 数值	-	0.33	-	$\text{V}/^{\circ}\text{C}$
I_{CES}	集电极切断电流	$V_{CE} = V_{CES}, V_{GE} = 0\text{ V}$	-	-	250	μA
I_{GES}	G-E 漏电流	$V_{GE} = V_{GES}, V_{CE} = 0\text{ V}$	-	-	± 400	nA
导通特性						
$V_{GE(th)}$	G-E 阈值电压	$I_C = 75\text{ mA}, V_{CE} = V_{GE}$	4	5.45	7.5	V
$V_{CE(sat)}$	集电极-发射极间饱和电压	$I_C = 75\text{ A}, V_{GE} = 15\text{ V}$	-	1.6	2.1	V
		$I_C = 75\text{ A}, V_{GE} = 15\text{ V}, T_C = 175^{\circ}\text{C}$	-	2.28	-	V
动态特性						
C_{ies}	输入电容	$V_{CE} = 30\text{ V}, V_{GE} = 0\text{ V}, f = 1\text{ MHz}$	-	3680	-	pF
C_{oes}	输出电容		-	179	-	pF
C_{res}	反向传输电容		-	43	-	pF
开关特性						
$t_{d(on)}$	导通延迟时间	$V_{CC} = 400\text{ V}, I_C = 75\text{ A}, R_G = 3\ \Omega, V_{GE} = 15\text{ V},$ 感性负载, $T_C = 25^{\circ}\text{C}$	-	28	-	ns
t_r	上升时间		-	56	-	ns
$t_{d(off)}$	关断延迟时间		-	80	-	ns
t_f	下降时间		-	14.4	-	ns
E_{on}	导通开关损耗		-	2.4	-	mJ
E_{off}	关断开关损耗		-	0.72	-	mJ
E_{ts}	总开关损耗		-	3.12	-	mJ
$t_{d(on)}$	导通延迟时间	$V_{CC} = 400\text{ V}, I_C = 75\text{ A}, R_G = 3\ \Omega, V_{GE} = 15\text{ V},$ 感性负载, $T_C = 175^{\circ}\text{C}$	-	26.4	-	ns
t_r	上升时间		-	58.4	-	ns
$t_{d(off)}$	关断延迟时间		-	86.4	-	ns
t_f	下降时间		-	13.6	-	ns
E_{on}	导通开关损耗		-	3.7	-	mJ
E_{off}	关断开关损耗		-	0.98	-	mJ
E_{ts}	总开关损耗		-	4.68	-	mJ

IGBT 电气特性 (接上页)

符号	参数	测试条件	最小值	典型值	最大值	单位
Q_g	总栅极电荷	$V_{CE} = 400\text{ V}$, $I_C = 75\text{ A}$, $V_{GE} = 15\text{ V}$	-	123	-	nC
Q_{ge}	栅极-发射极间电荷		-	22.6	-	nC
Q_{gc}	栅极-集电极间电荷		-	44.9	-	nC

二极管电气特性 $T_C = 25^\circ\text{C}$ 除非另有说明

符号	参数	测试条件	最小值	典型值	最大值	单位	
V_{FM}	二极管正向电压	$I_F = 50\text{ A}$	$T_C = 25^\circ\text{C}$	-	2.2	2.8	V
			$T_C = 175^\circ\text{C}$	-	1.8	-	
E_{rec}	反向恢复电能	$I_F = 50\text{ A}$, $di_F/dt = 200\text{ A}/\mu\text{s}$	$T_C = 175^\circ\text{C}$	-	60	-	μJ
t_{rr}	二极管反向恢复时间		$T_C = 25^\circ\text{C}$	-	43.4	-	ns
			$T_C = 175^\circ\text{C}$	-	207	-	
Q_{rr}	二极管反向恢复电荷		$T_C = 25^\circ\text{C}$	-	87.9	-	nC
		$T_C = 175^\circ\text{C}$	-	1243	-		

典型性能特征

图 1. 典型输出特性



图 2. 典型输出特性



图 3. 典型饱和电压特性

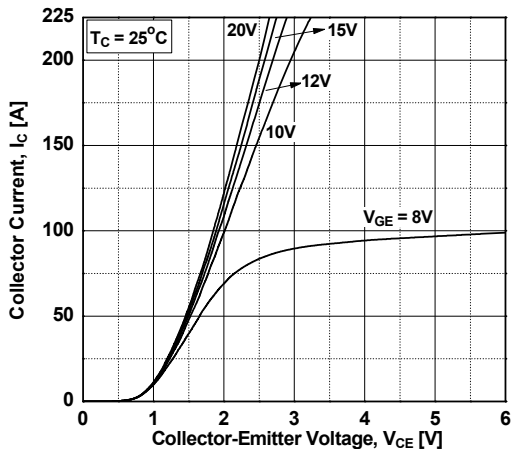

图 4. 饱和电压与可变电流强度下壳温的关系

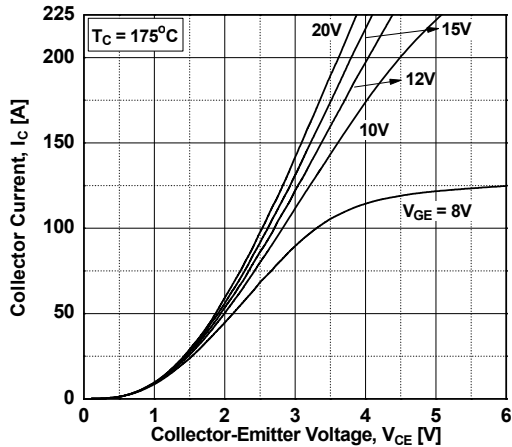

图 5. 饱和电压与 Vge 的关系

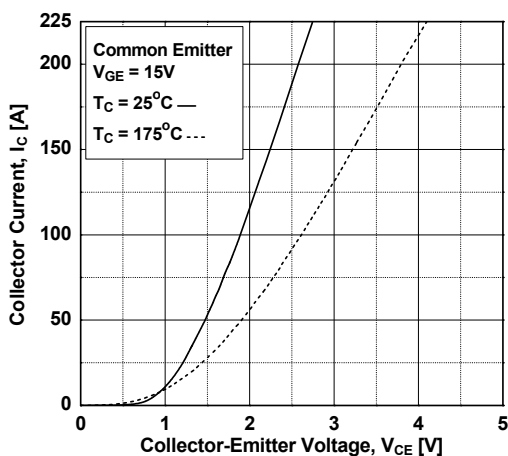

图 6. 饱和电压与 Vge 的关系

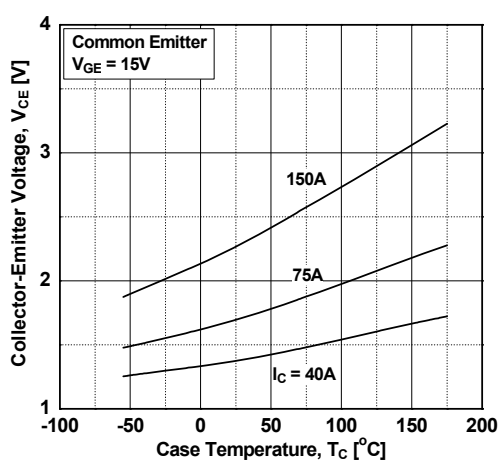

典型性能特征

图 7. 电容特性

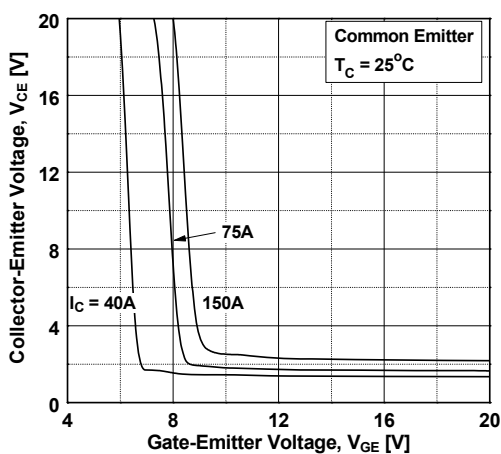
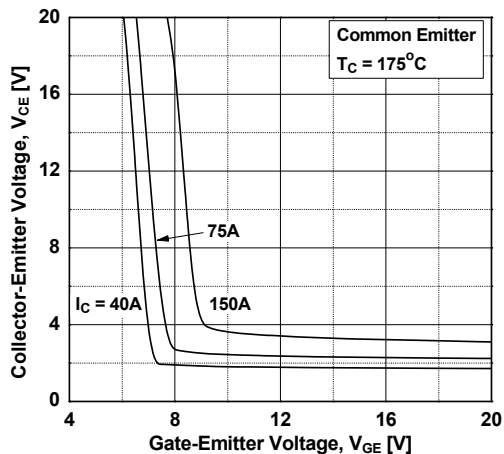

图 8. 栅极电荷特性



图 9. 导通特性与栅极电阻的关系

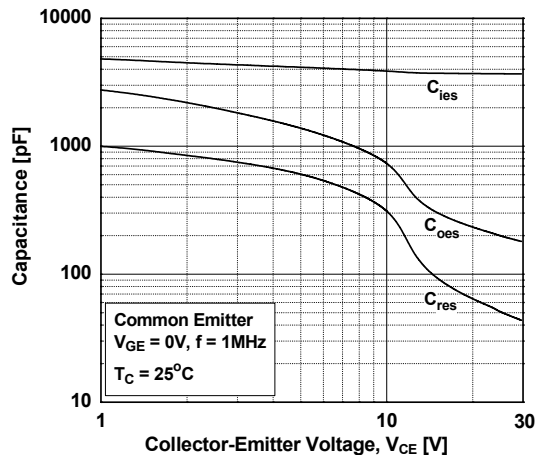

图 10. 关断特性与栅极电阻的关系

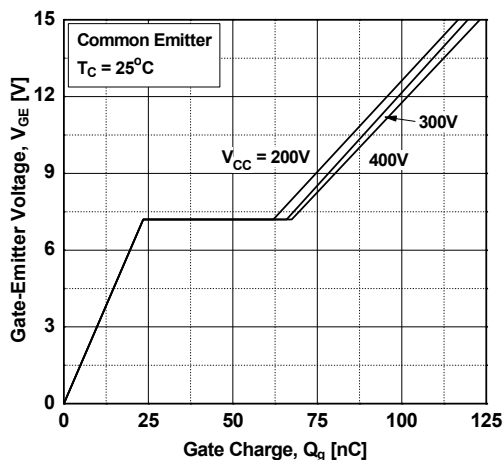

图 11. 开关损耗与栅极电阻的关系

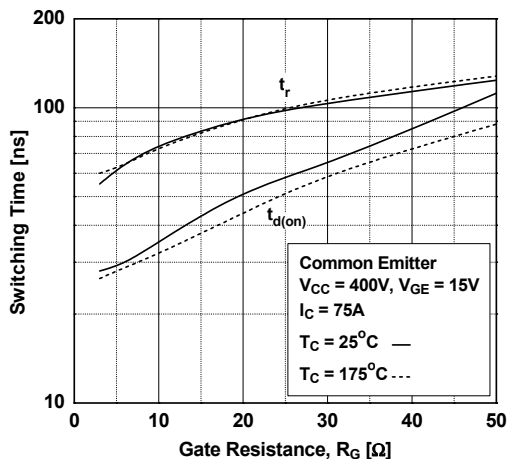

图 12. 导通特性与集电极电流的关系

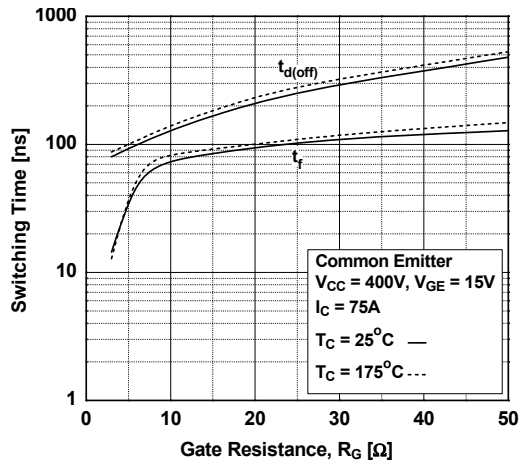

典型性能特征

图 13. 关断特性与集电极电流的关系

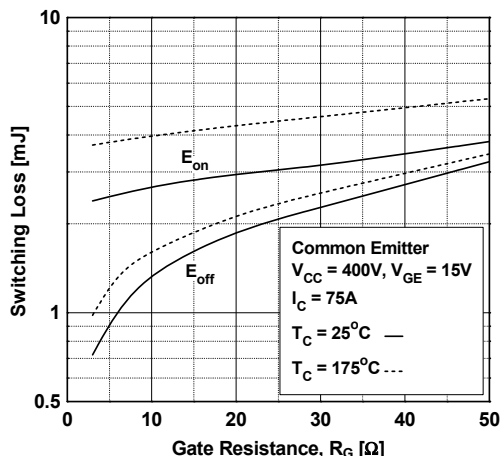
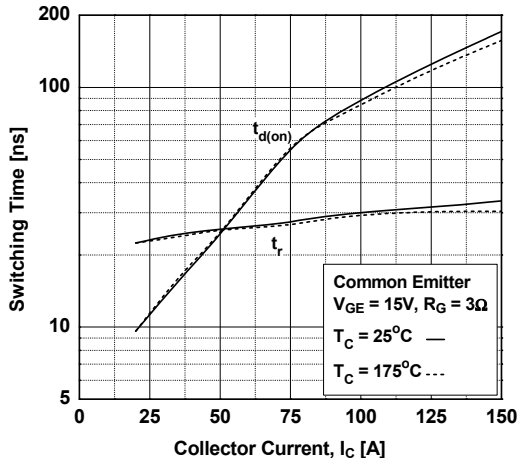

图 14. 开关损耗与集电极电流的关系



图 15. 负载电流与频率的关系

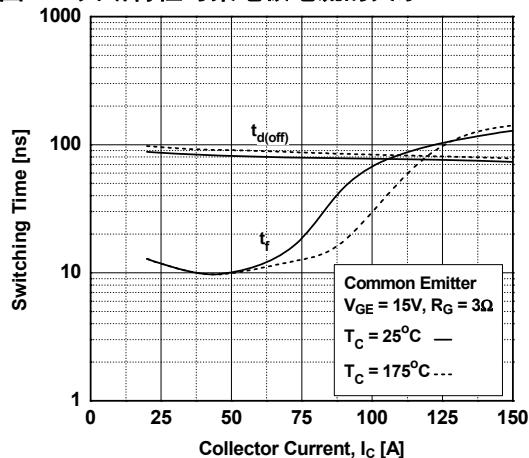

图 16. SOA 特性

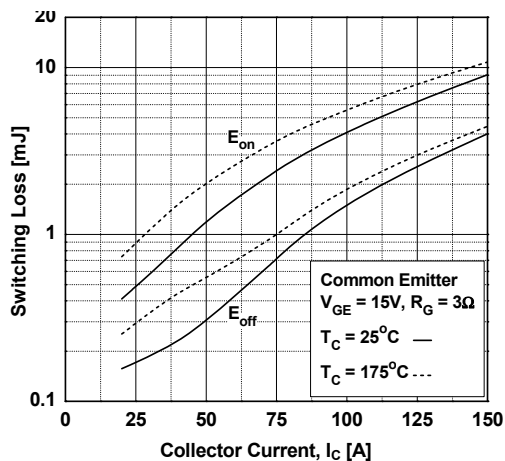

图 17. 正向特性

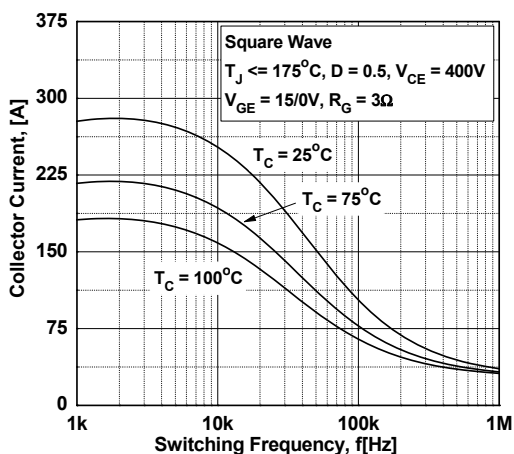

图 18. 反向恢复电流

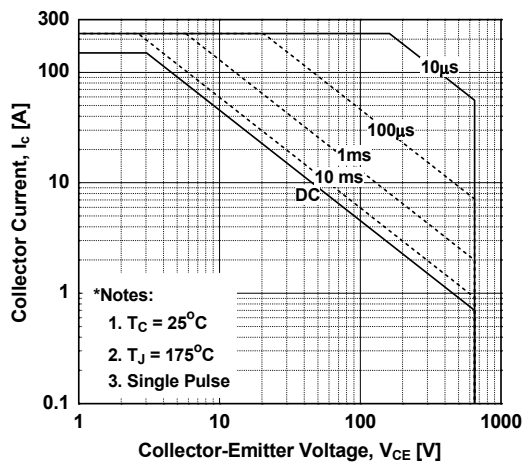

典型性能特征

图 19. 反向恢复时间

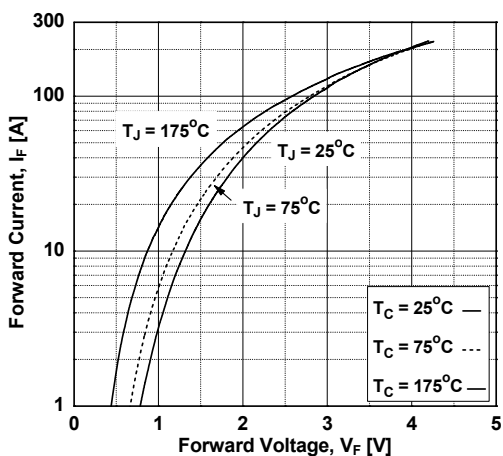
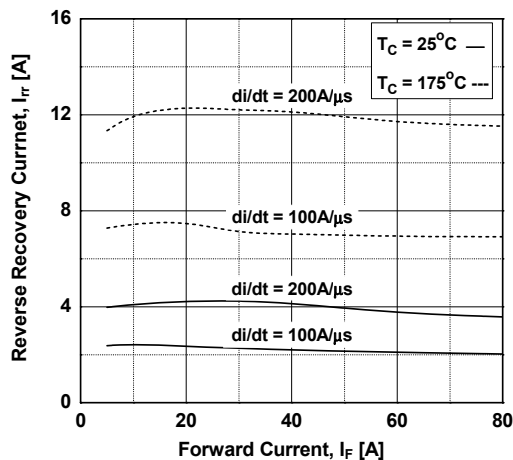

图 20. 存储电荷



图 21. IGBT 的瞬态热阻

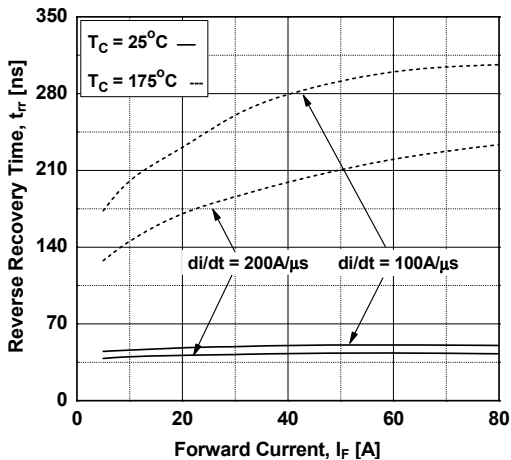

图 22. 二极管瞬态热阻抗

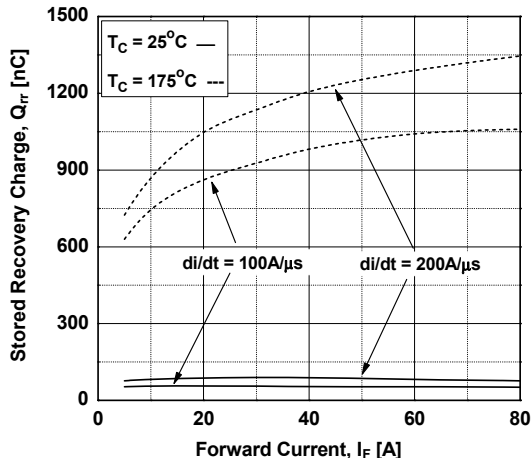

机械尺寸

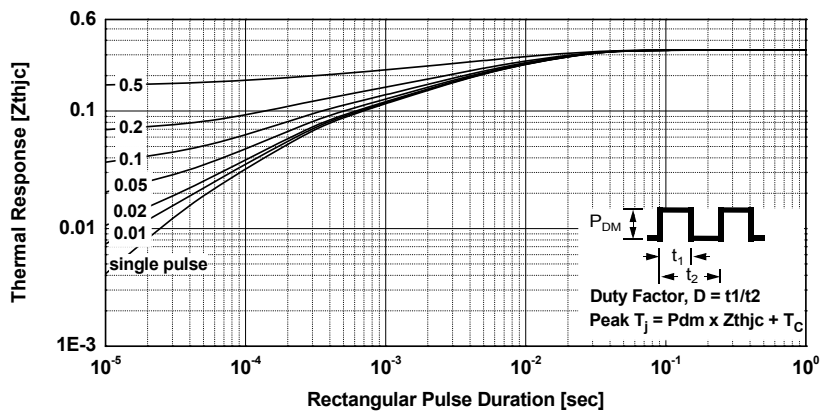
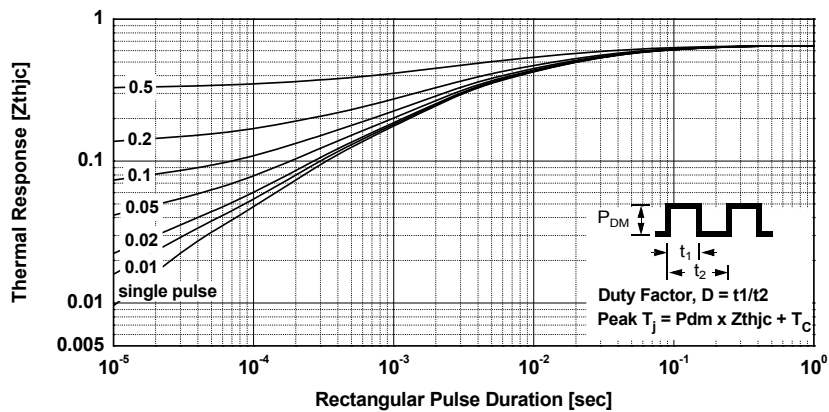
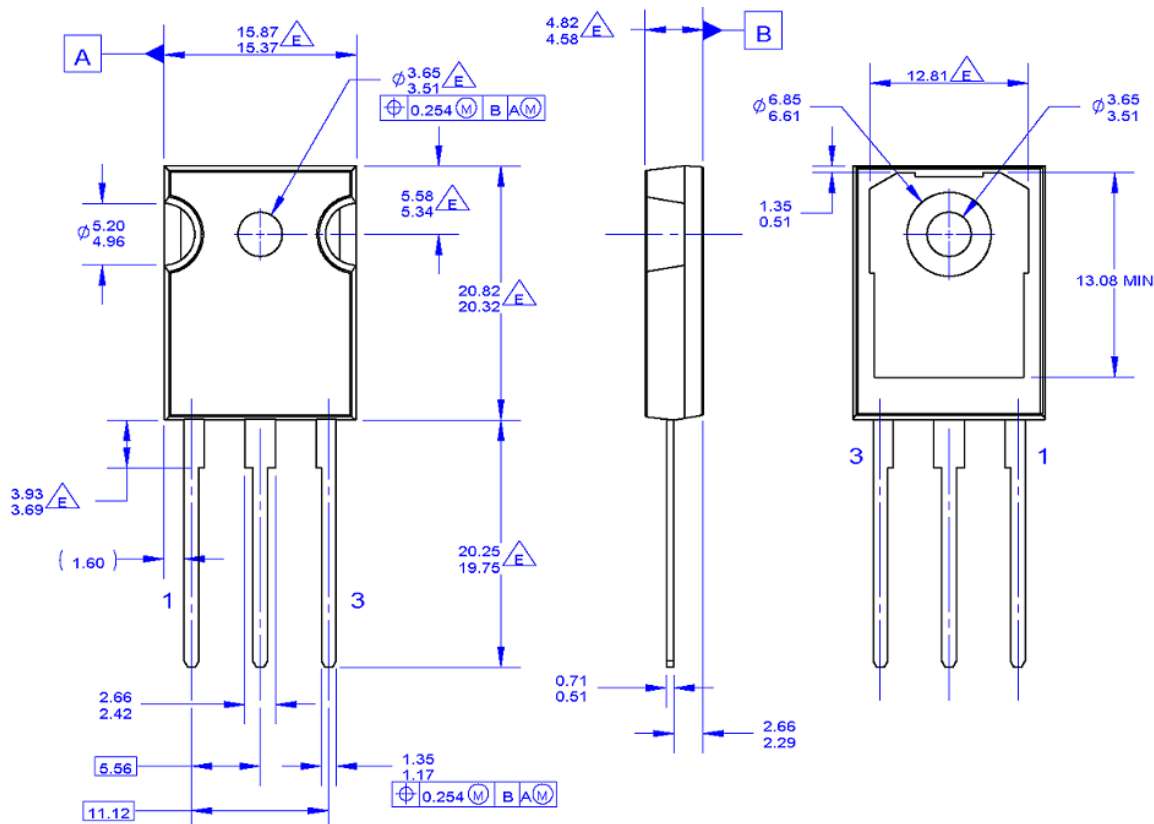

NOTES: UNLESS OTHERWISE SPECIFIED.

- A. PACKAGE REFERENCE: JEDEC TO-247, ISSUE E, VARIATION AB, DATED JUNE, 2004.
- B. DIMENSIONS ARE EXCLUSIVE OF BURRS, MOLD FLASH, AND TIE BAR EXTRUSIONS.
- C. ALL DIMENSIONS ARE IN MILLIMETERS.
- D. DRAWING CONFORMS TO ASME Y14.5 - 1994

- $\triangle E$ DOES NOT COMPLY JEDEC STANDARD VALUE
- F. DRAWING FILENAME: MKT-TO247G03_REV01

图 23. TO-247 3L - TO-247, 模塑封装, 3 引脚, JEDEC AB 长引脚

封装图纸是作为一项服务提供给考虑飞兆半导体元件的客户的。图纸可能会在没有任何通知的情况下做出一些改动。请注意图纸上的版本或日期, 如有疑问, 请联系飞兆半导体代表核实或获得最新版本。封装规格并不扩大飞兆半导体全球范围内的条款与条件, 尤其是其中涉及飞兆半导体产品保修的部分。

ON Semiconductor and  are trademarks of Semiconductor Components Industries, LLC dba ON Semiconductor or its subsidiaries in the United States and/or other countries. ON Semiconductor owns the rights to a number of patents, trademarks, copyrights, trade secrets, and other intellectual property. A listing of ON Semiconductor's product/patent coverage may be accessed at www.onsemi.com/site/pdf/Patent-Marking.pdf. ON Semiconductor reserves the right to make changes without further notice to any products herein. ON Semiconductor makes no warranty, representation or guarantee regarding the suitability of its products for any particular purpose, nor does ON Semiconductor assume any liability arising out of the application or use of any product or circuit, and specifically disclaims any and all liability, including without limitation special, consequential or incidental damages. Buyer is responsible for its products and applications using ON Semiconductor products, including compliance with all laws, regulations and safety requirements or standards, regardless of any support or applications information provided by ON Semiconductor. "Typical" parameters which may be provided in ON Semiconductor data sheets and/or specifications can and do vary in different applications and actual performance may vary over time. All operating parameters, including "Typicals" must be validated for each customer application by customer's technical experts. ON Semiconductor does not convey any license under its patent rights nor the rights of others. ON Semiconductor products are not designed, intended, or authorized for use as a critical component in life support systems or any FDA Class 3 medical devices or medical devices with a same or similar classification in a foreign jurisdiction or any devices intended for implantation in the human body. Should Buyer purchase or use ON Semiconductor products for any such unintended or unauthorized application, Buyer shall indemnify and hold ON Semiconductor and its officers, employees, subsidiaries, affiliates, and distributors harmless against all claims, costs, damages, and expenses, and reasonable attorney fees arising out of, directly or indirectly, any claim of personal injury or death associated with such unintended or unauthorized use, even if such claim alleges that ON Semiconductor was negligent regarding the design or manufacture of the part. ON Semiconductor is an Equal Opportunity/Affirmative Action Employer. This literature is subject to all applicable copyright laws and is not for resale in any manner.

PUBLICATION ORDERING INFORMATION

LITERATURE FULFILLMENT:

Literature Distribution Center for ON Semiconductor
19521 E. 32nd Pkwy, Aurora, Colorado 80011 USA
Phone: 303-675-2175 or 800-344-3860 Toll Free USA/Canada
Fax: 303-675-2176 or 800-344-3867 Toll Free USA/Canada
Email: orderlit@onsemi.com

N. American Technical Support: 800-282-9855 Toll Free
USA/Canada
Europe, Middle East and Africa Technical Support:
Phone: 421 33 790 2910
Japan Customer Focus Center
Phone: 81-3-5817-1050

ON Semiconductor Website: www.onsemi.com
Order Literature: <http://www.onsemi.com/orderlit>
For additional information, please contact your local
Sales Representative