

IGBT, 场截止

600 V, 75 A

FGY75N60SMD

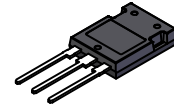

TO-247-3LD
CASE 340CD

概述

安森美的场截止第二代 IGBT 新系列采用新型场截止 IGBT 技术, 为光伏逆变器、UPS、焊机和 PFC 等低导通和开关损耗至关重要的应用提供最佳性能。

特性

- 高电流能力
- 低饱和电压: $V_{CE(sat)} = 1.9\text{ V @ } I_C = 75\text{ A}$
- 高输入阻抗
- 快速开关 $E_{OFF} = 13\text{ }\mu\text{J/A}$
- 符合 RoHS 标准

应用

- 太阳能逆变器、UPS、电焊机、SMPS、PFC

绝对最大额定值

符号	说明	额定值	单位
V_{CES}	集电极-发射极之间电压	600	V
V_{GES}	栅极-发射极间电压	± 20	V
	瞬态栅极至发射极电压	± 30	V
I_C	集电极电流, @ $T_C = 25^\circ\text{C}$	150	A
	集电极电流, @ $T_C = 100^\circ\text{C}$	75	A
$I_{CM(1)}$	集电极脉冲电流, @ $T_C = 25^\circ\text{C}$	225	A
I_F	二极管正向电流, @ $T_C = 25^\circ\text{C}$	75	A
	二极管正向电流, @ $T_C = 100^\circ\text{C}$	50	A
$I_{FM(1)}$	二极管最大正向脉冲电流	225	A
P_D	最大功耗, @ $T_C = 25^\circ\text{C}$	750	W
	最大功耗, @ $T_C = 100^\circ\text{C}$	375	W
T_J	工作结温	-55 至 +175	$^\circ\text{C}$
T_{stg}	存储温度范围	-55 至 +175	$^\circ\text{C}$
T_L	用于焊接的最大引脚温度, 距离外壳, 1/8" 持续 5 秒	300	$^\circ\text{C}$

Stresses exceeding those listed in the Maximum Ratings table may damage the device. If any of these limits are exceeded, device functionality should not be assumed, damage may occur and reliability may be affected.

(参考译文)

如果电压超过最大额定值表中列出的值范围, 器件可能会损坏。如果超过任何这些限值, 将无法保证器件功能, 可能会导致器件损坏, 影响可靠性。

1. 重复率额定值: 脉冲宽度受限于最大值结温

热性能

符号	参数	典型值	最大值	单位
$R_{\theta JC}(\text{IGBT})$	集电极-发射极之间电压	-	0.2	$^\circ\text{C/W}$
$R_{\theta JC}(\text{Diode})$	结点-壳体的热阻	-	0.48	$^\circ\text{C/W}$
$R_{\theta JA}$	结至环境热阻	-	40	$^\circ\text{C/W}$

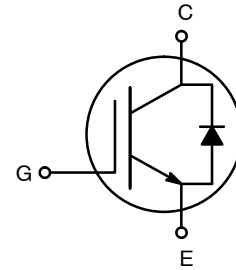

MARKING DIAGRAM

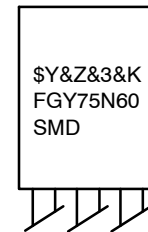

\$Y = Logo
&Z = Assembly Plant Code
&3 = Date Code (Year & Week)
&K = Lot Run Traceability Code
FGY75N60SMD = Specific Device Code

ORDERING INFORMATION

Device	Package	Shipping
FGY75N60SMD	TO-247-3LD (Pb-Free)	450 / Tube

FGY75N60SMD

IGBT 电气特性 (T_C = 25°C 除非另有说明)

符号	参数	测试条件	最小值	典型值	最大值	单位
关断特性						
BV _{CES}	集电极-发射极击穿电压	V _{GE} = 0 V, I _C = 250 μA	600	-	-	V
ΔBV _{CES} / ΔT _J	击穿温度系数电压	V _{GE} = 0 V, I _C = 250 μA	-	0.67	-	V/°C
I _{CES}	集电极切断电流	V _{CE} = V _{CES} , V _{GE} = 0 V	-	-	250	μA
I _{GES}	G-E 漏电流	V _{GE} = V _{GES} , V _{CE} = 0 V	-	-	±400	nA
导通特性						
V _{GE(th)}	G-E 阈值电压	I _C = 250 μA, V _{CE} = V _{GE}	3.5	5.0	6.5	V
V _{CE(sat)}	集电极-发射极饱和电压	I _C = 75 A, V _{GE} = 15 V	-	1.90	2.50	V
		I _C = 75 A, V _{GE} = 15 V, T _C = 175°C	-	2.14	-	V
动态特性						
C _{ies}	输入电容	V _{CE} = 30 V, V _{GE} = 0 V, f = 1 MHz	-	3800	-	pF
C _{oes}	输出电容		-	390	-	pF
C _{res}	反向传输电容		-	105	-	pF
开关特性						
t _{d(on)}	导通延迟时间	V _{CC} = 400 V, I _C = 75 A, R _G = 3 Ω, V _{GE} = 15 V, 感性负载, T _C = 25°C	-	24	32	ns
t _r	上升时间		-	56	73	ns
t _{d(off)}	关断延迟时间		-	136	177	ns
t _f	下降时间		-	22	29	ns
E _{on}	导通开关损耗		-	2.3	2.99	mJ
E _{off}	关断开关损耗		-	0.77	1.00	mJ
E _{ts}	总开关损耗		-	3.07	3.99	mJ
t _{d(on)}	导通延迟时间	V _{CC} = 400 V, I _C = 75 A, R _G = 3 Ω, V _{GE} = 15 V, 感性负载, T _C = 175°C	-	23	-	ns
t _r	上升时间		-	53	-	ns
t _{d(off)}	关断延迟时间		-	146	-	ns
t _f	下降时间		-	15	-	ns
E _{on}	导通开关损耗		-	3.60	-	mJ
E _{off}	关断开关损耗		-	1.11	-	mJ
E _{ts}	总开关损耗		-	4.71	-	mJ
Q _g	总栅极电荷	V _{CE} = 400 V, I _C = 75 A, V _{GE} = 15 V	-	248	370	nC
Q _{ge}	栅极-发射极间电荷		-	28	42	nC
Q _{gc}	栅极-发射极间电荷		-	129	195	nC

Product parametric performance is indicated in the Electrical Characteristics for the listed test conditions, unless otherwise noted. Product performance may not be indicated by the Electrical Characteristics if operated under different conditions.

(参考译文)

除非另有说明,“电气特性”表格中列出的是所列测试条件下的产品性能参数。如果在不同条件下运行,产品性能可能与“电气特性”表格中所列性能参数不一致。

二极管电气特性 (T_C = 25°C 除非另有说明)

符号	参数	测试条件	最小值	典型值	最大值	单位	
V _{FM}	二极管正向电压	I _F = 50 A	T _C = 25°C	-	1.75	2.1	V
			T _C = 175°C	-	1.35	-	
E _{rec}	反向恢复电能	I _F = 50 A, di _F /dt = 200 A/μs V _R = 400 V	T _C = 175°C	-	0.14	-	mJ
t _{rr}	二极管反向恢复时间		T _C = 25°C	-	41	55	ns
			T _C = 175°C	-	126	-	
Q _{rr}	二极管反向恢复电荷		T _C = 25°C	-	81	115	nC
		T _C = 175°C	-	736	-		

Product parametric performance is indicated in the Electrical Characteristics for the listed test conditions, unless otherwise noted. Product performance may not be indicated by the Electrical Characteristics if operated under different conditions.

(参考译文)

除非另有说明,“电气特性”表格中列出的是所列测试条件下的产品性能参数。如果在不同条件下运行,产品性能可能与“电气特性”表格中所列性能参数不一致。

典型性能特征



图 1. 典型输出特性



图 2. 典型输出特性

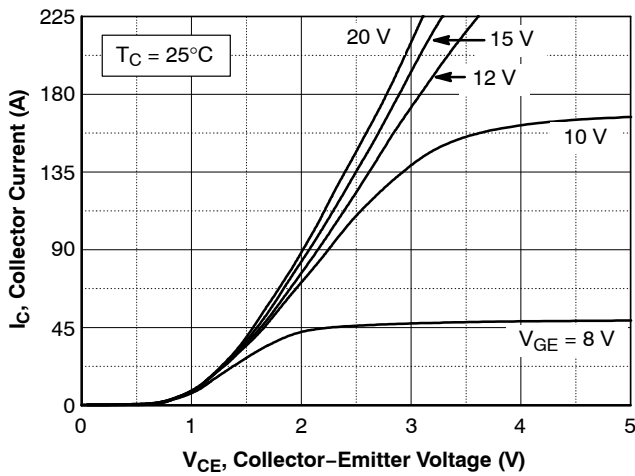

图 3. 典型饱和电压特性

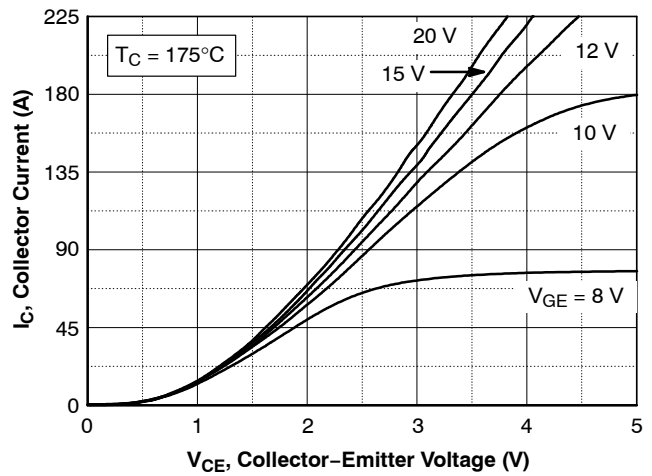

图 4. 传递特性

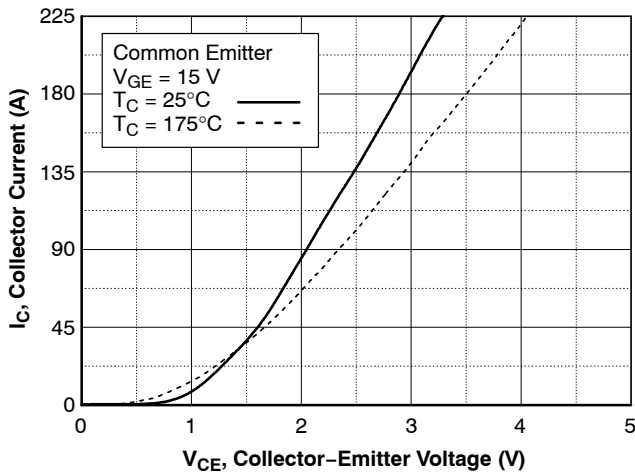

图 5. 饱和电压与外壳的关系在不同电流下的温度

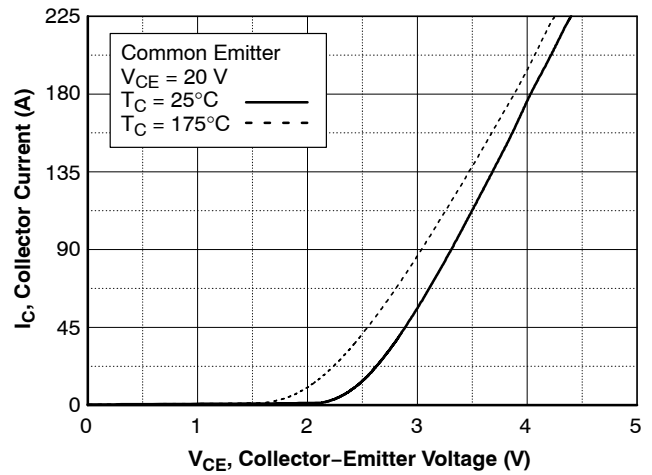

图 6. 饱和电压与 VGE 的关系

典型性能特征 (Continued)

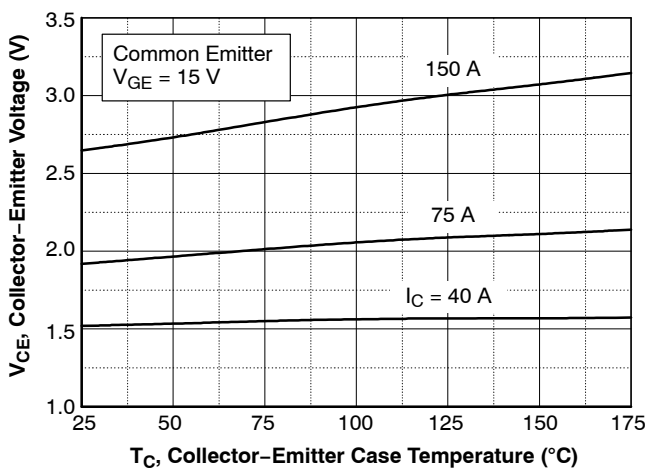

图 7. 饱和电压与 V_{GE} 的关系

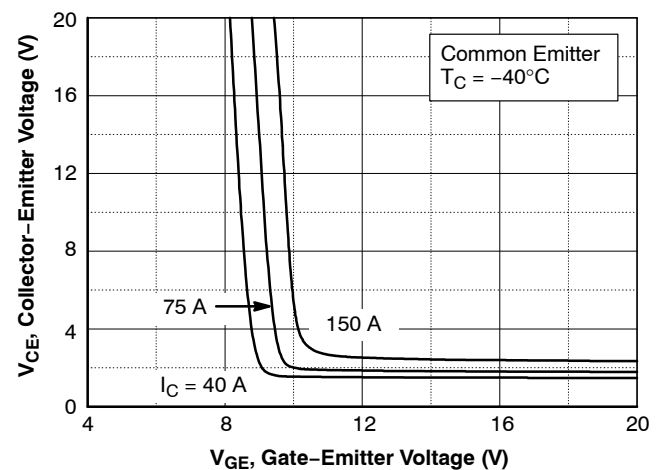

图 8. 饱和电压与 V_{GE} 的关系

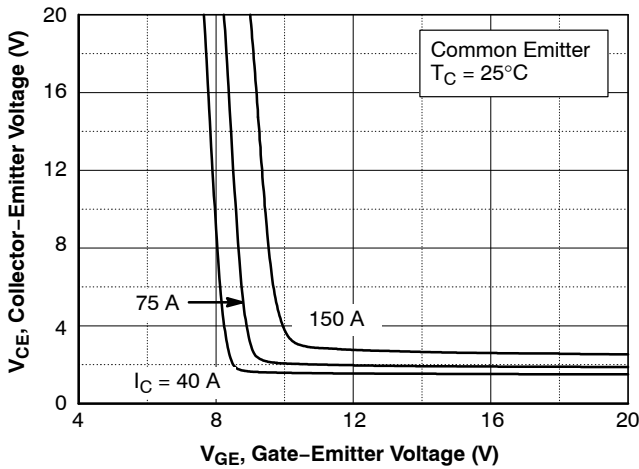

图 9. 电容特性

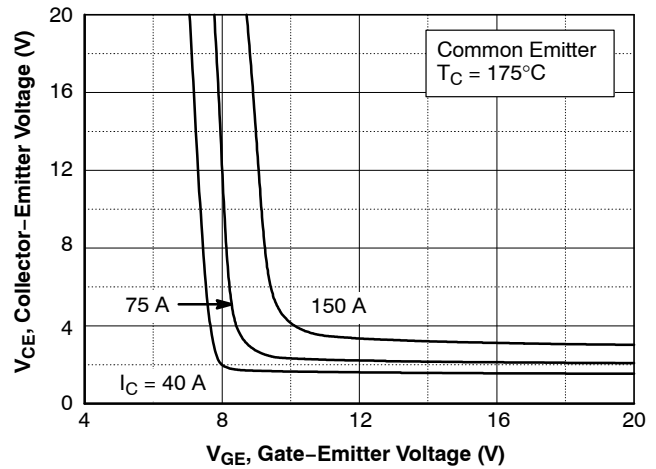

图 10. 栅极电荷特性

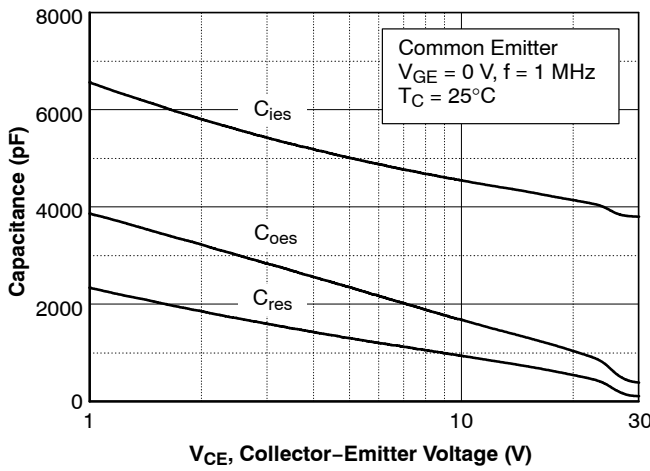

图 11. 关断特性与栅极电阻

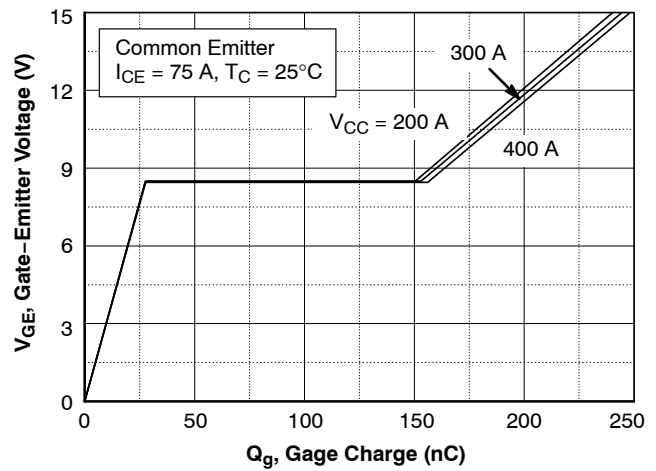

图 12. 开启特性与栅极电阻

典型性能特征 (Continued)

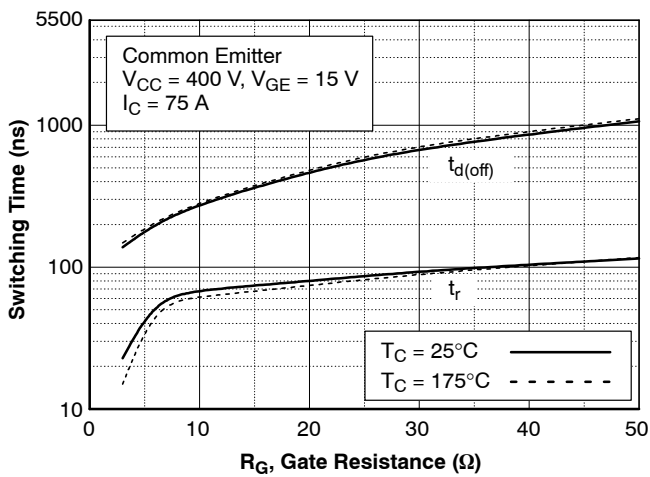

图 13. 关断特性与集电极电流的关系

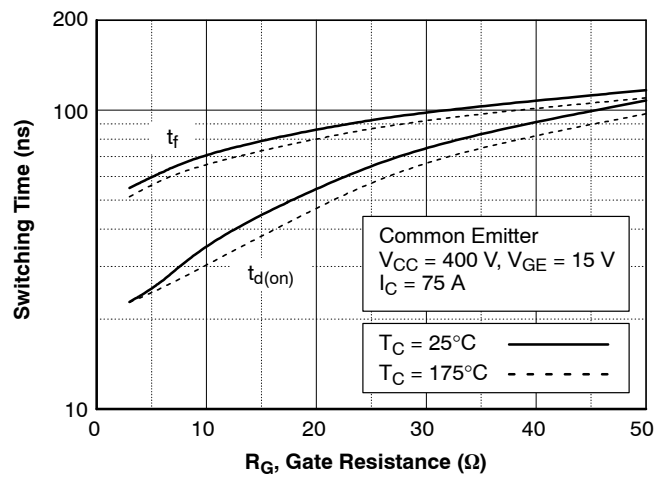

图 14. 开启特性与集电极电流

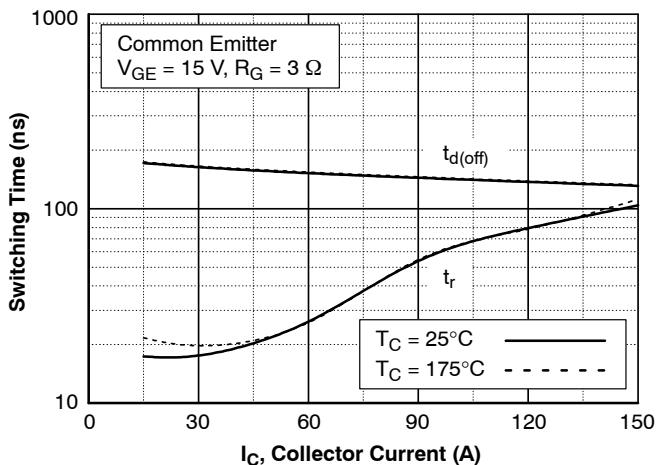

图 15. 开关损耗与集电极电流的关系

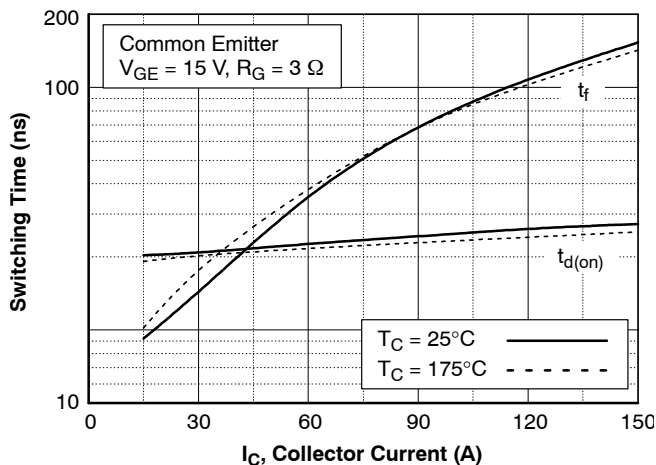

图 16. 开关损耗与栅极电阻

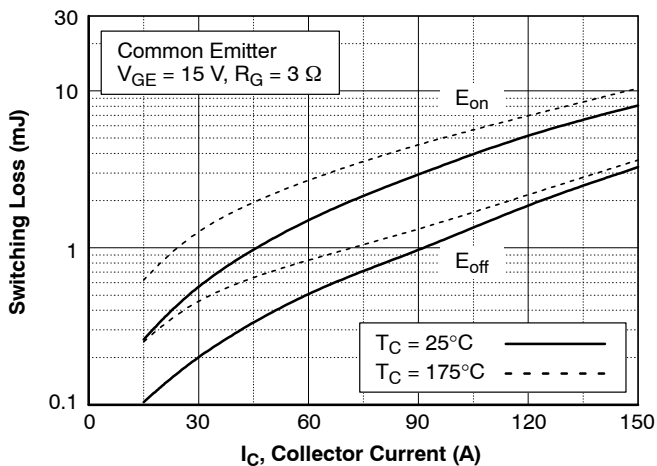

图 17. SOA 特性

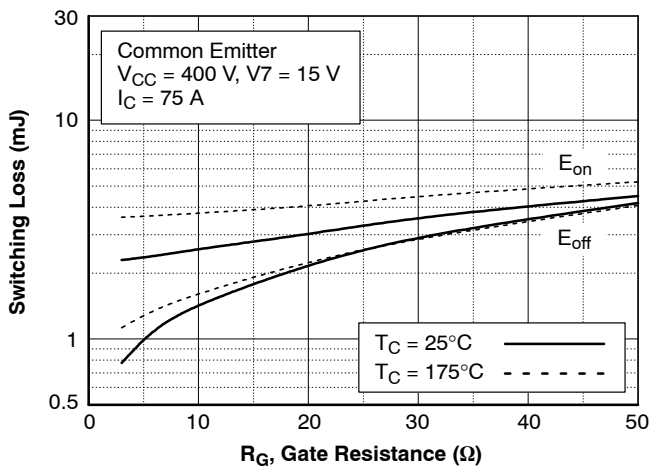

图 18. 关断开关 SOA 特性

FGY75N60SMD

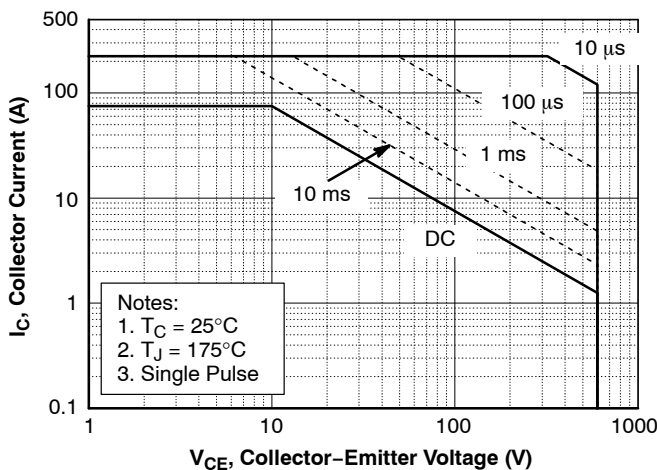
典型性能特征 (Continued)

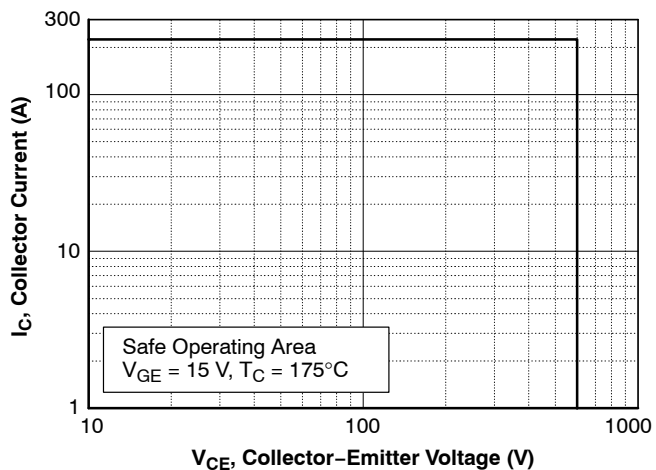

图 19. 电流降额



图 20. 负载电流与频率的关系

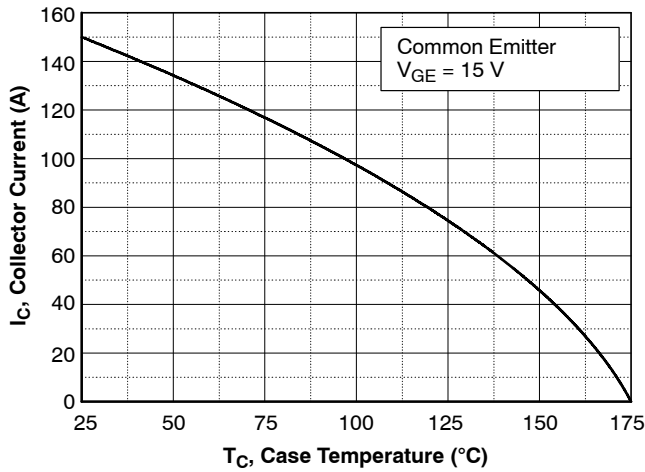

图 21. 正向特性

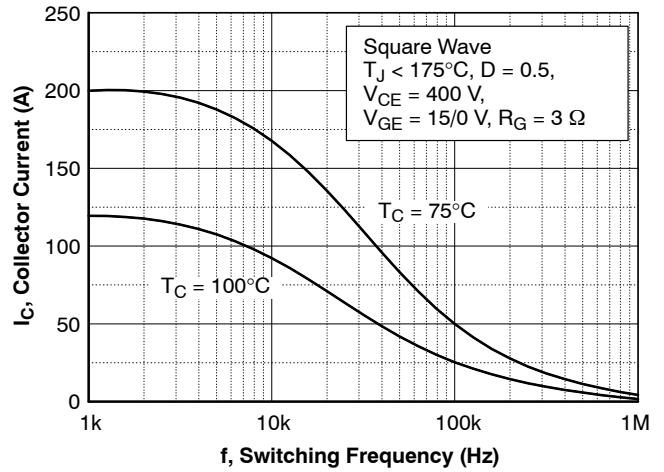

图 22. 反向电流

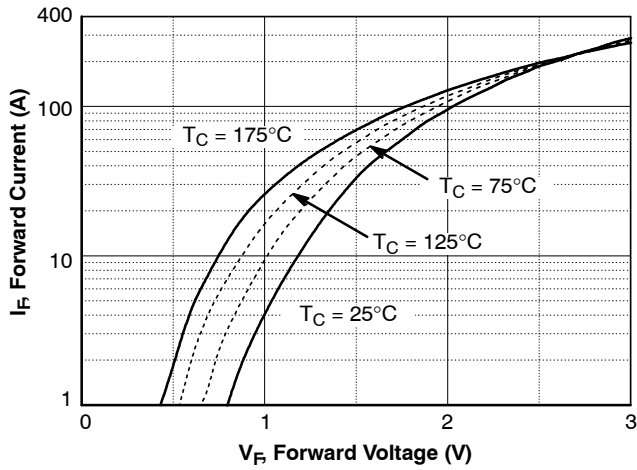

图 23. 存储电荷

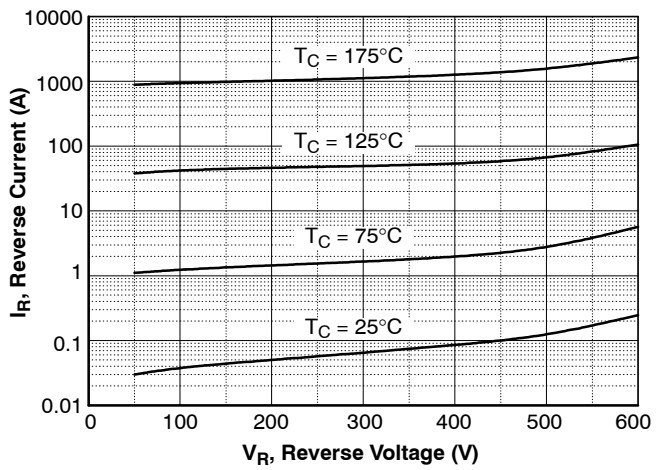

图 24. 反向恢复电流

FGY75N60SMD

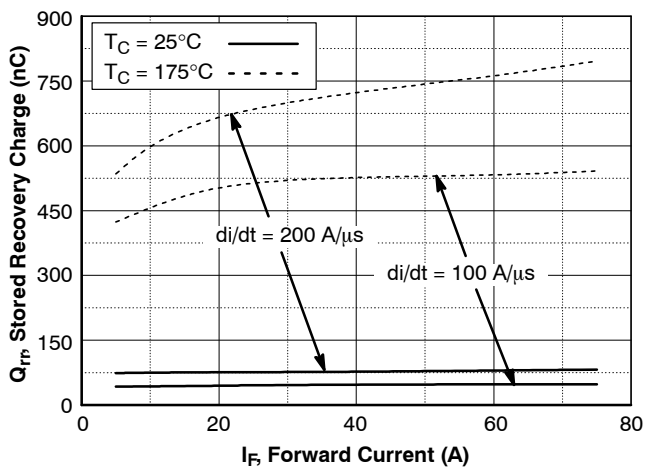
典型性能特征 (Continued)

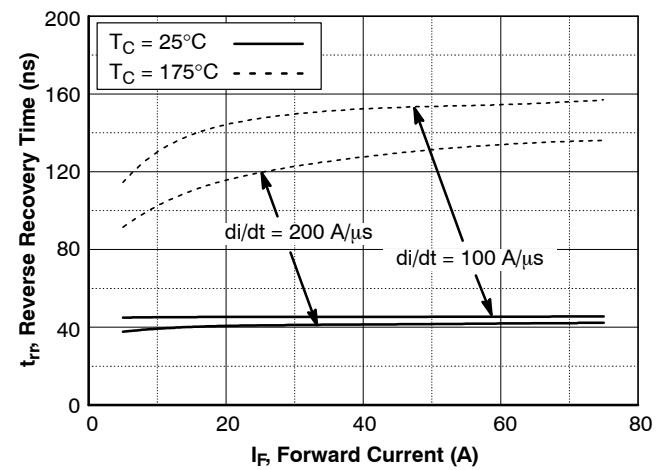

图 25. IGBT 瞬态热阻抗



图 26. 二极管瞬态热阻抗

MECHANICAL CASE OUTLINE

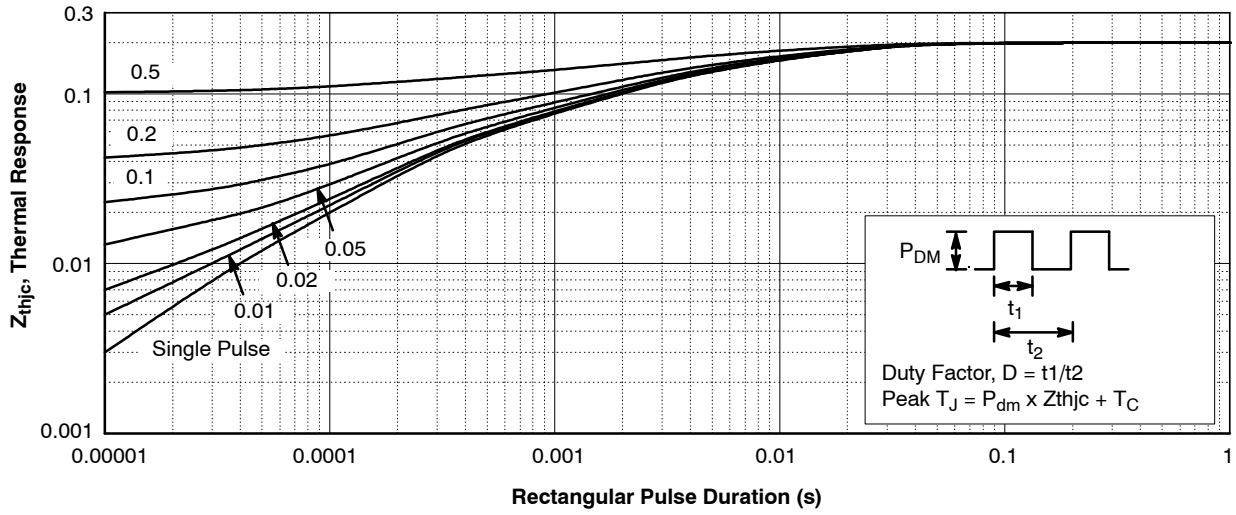
PACKAGE DIMENSIONS

ON Semiconductor®

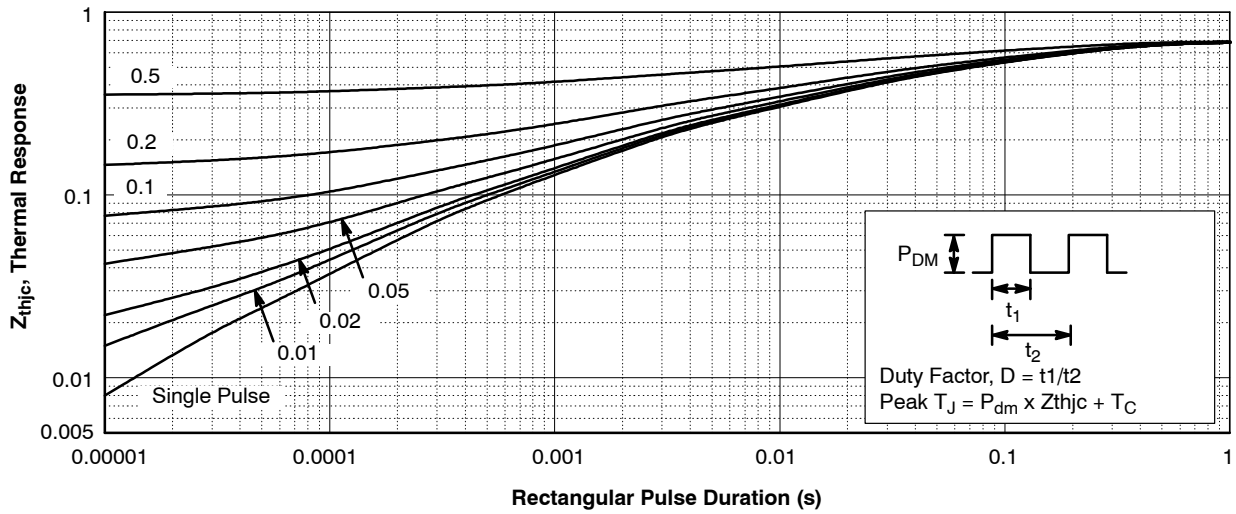

TO-247-3LD
CASE 340CD
ISSUE A

DATE 18 SEP 2018

NOTES:

- A. THIS PACKAGE DOES NOT CONFORM TO ANY STANDARDS.
- B. ALL DIMENSIONS ARE IN MILLIMETERS.
- C. DIMENSIONS ARE EXCLUSIVE OF BURRS, MOLD FLASH AND TIE BAR PROTRUSIONS.
- D. DIMENSION AND TOLERANCE AS PER ASME Y14.5-2009.



DIM	MILLIMETERS		
	MIN	NOM	MAX
A	4.58	4.70	4.82
A1	2.20	2.40	2.60
A2	1.80	2.00	2.20
D	20.32	20.57	20.82
E	15.37	15.62	15.87
E2	4.12	4.32	4.52
e	~	5.45	~
L	19.90	20.00	20.10
L1	3.69	3.81	3.93
Q	5.34	5.46	5.58
b	1.10	1.20	1.30
b2	2.10	2.24	2.39
b4	2.87	3.04	3.20
c	0.51	0.61	0.71
D1	16.63	16.83	17.03
D2	0.51	0.93	1.35
E1	13.40	13.60	13.80

GENERIC MARKING DIAGRAM*

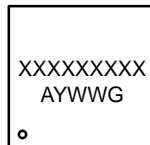

- XXXX = Specific Device Code
- A = Assembly Location
- Y = Year
- WW = Work Week
- G = Pb-Free Package

*This information is generic. Please refer to device data sheet for actual part marking. Pb-Free indicator, "G" or microdot "•", may or may not be present. Some products may not follow the Generic Marking.

DOCUMENT NUMBER:	98AON13857G	Electronic versions are uncontrolled except when accessed directly from the Document Repository. Printed versions are uncontrolled except when stamped "CONTROLLED COPY" in red.
DESCRIPTION:	TO-247-3LD	PAGE 1 OF 1

ON Semiconductor and are trademarks of Semiconductor Components Industries, LLC dba ON Semiconductor or its subsidiaries in the United States and/or other countries. ON Semiconductor reserves the right to make changes without further notice to any products herein. ON Semiconductor makes no warranty, representation or guarantee regarding the suitability of its products for any particular purpose, nor does ON Semiconductor assume any liability arising out of the application or use of any product or circuit, and specifically disclaims any and all liability, including without limitation special, consequential or incidental damages. ON Semiconductor does not convey any license under its patent rights nor the rights of others.

onsemi, **Onsemi**, and other names, marks, and brands are registered and/or common law trademarks of Semiconductor Components Industries, LLC dba "**onsemi**" or its affiliates and/or subsidiaries in the United States and/or other countries. **onsemi** owns the rights to a number of patents, trademarks, copyrights, trade secrets, and other intellectual property. A listing of **onsemi**'s product/patent coverage may be accessed at www.onsemi.com/site/pdf/Patent-Marking.pdf. **onsemi** reserves the right to make changes at any time to any products or information herein, without notice. The information herein is provided "as-is" and **onsemi** makes no warranty, representation or guarantee regarding the accuracy of the information, product features, availability, functionality, or suitability of its products for any particular purpose, nor does **onsemi** assume any liability arising out of the application or use of any product or circuit, and specifically disclaims any and all liability, including without limitation special, consequential or incidental damages. Buyer is responsible for its products and applications using **onsemi** products, including compliance with all laws, regulations and safety requirements or standards, regardless of any support or applications information provided by **onsemi**. "Typical" parameters which may be provided in **onsemi** data sheets and/or specifications can and do vary in different applications and actual performance may vary over time. All operating parameters, including "Typicals" must be validated for each customer application by customer's technical experts. **onsemi** does not convey any license under any of its intellectual property rights nor the rights of others. **onsemi** products are not designed, intended, or authorized for use as a critical component in life support systems or any FDA Class 3 medical devices or medical devices with a same or similar classification in a foreign jurisdiction or any devices intended for implantation in the human body. Should Buyer purchase or use **onsemi** products for any such unintended or unauthorized application, Buyer shall indemnify and hold **onsemi** and its officers, employees, subsidiaries, affiliates, and distributors harmless against all claims, costs, damages, and expenses, and reasonable attorney fees arising out of, directly or indirectly, any claim of personal injury or death associated with such unintended or unauthorized use, even if such claim alleges that **onsemi** was negligent regarding the design or manufacture of the part. **onsemi** is an Equal Opportunity/Affirmative Action Employer. This literature is subject to all applicable copyright laws and is not for resale in any manner.

ADDITIONAL INFORMATION

TECHNICAL PUBLICATIONS:

Technical Library: www.onsemi.com/design/resources/technical-documentation
onsemi Website: www.onsemi.com

ONLINE SUPPORT: www.onsemi.com/support

For additional information, please contact your local Sales Representative at www.onsemi.com/support/sales