



Is Now Part of



ON Semiconductor®

To learn more about ON Semiconductor, please visit our website at
www.onsemi.com

Please note: As part of the Fairchild Semiconductor integration, some of the Fairchild orderable part numbers will need to change in order to meet ON Semiconductor's system requirements. Since the ON Semiconductor product management systems do not have the ability to manage part nomenclature that utilizes an underscore (_), the underscore (_) in the Fairchild part numbers will be changed to a dash (-). This document may contain device numbers with an underscore (_). Please check the ON Semiconductor website to verify the updated device numbers. The most current and up-to-date ordering information can be found at www.onsemi.com. Please email any questions regarding the system integration to Fairchild_questions@onsemi.com.

ON Semiconductor and the ON Semiconductor logo are trademarks of Semiconductor Components Industries, LLC dba ON Semiconductor or its subsidiaries in the United States and/or other countries. ON Semiconductor owns the rights to a number of patents, trademarks, copyrights, trade secrets, and other intellectual property. A listing of ON Semiconductor's product/patent coverage may be accessed at www.onsemi.com/site/pdf/Patent-Marking.pdf. ON Semiconductor reserves the right to make changes without further notice to any products herein. ON Semiconductor makes no warranty, representation or guarantee regarding the suitability of its products for any particular purpose, nor does ON Semiconductor assume any liability arising out of the application or use of any product or circuit, and specifically disclaims any and all liability, including without limitation special, consequential or incidental damages. Buyer is responsible for its products and applications using ON Semiconductor products, including compliance with all laws, regulations and safety requirements or standards, regardless of any support or applications information provided by ON Semiconductor. "Typical" parameters which may be provided in ON Semiconductor data sheets and/or specifications can and do vary in different applications and actual performance may vary over time. All operating parameters, including "Typicals" must be validated for each customer application by customer's technical experts. ON Semiconductor does not convey any license under its patent rights nor the rights of others. ON Semiconductor products are not designed, intended, or authorized for use as a critical component in life support systems or any FDA Class 3 medical devices or medical devices with a same or similar classification in a foreign jurisdiction or any devices intended for implantation in the human body. Should Buyer purchase or use ON Semiconductor products for any such unintended or unauthorized application, Buyer shall indemnify and hold ON Semiconductor and its officers, employees, subsidiaries, affiliates, and distributors harmless against all claims, costs, damages, and expenses, and reasonable attorney fees arising out of, directly or indirectly, any claim of personal injury or death associated with such unintended or unauthorized use, even if such claim alleges that ON Semiconductor was negligent regarding the design or manufacture of the part. ON Semiconductor is an Equal Opportunity/Affirmative Action Employer. This literature is subject to all applicable copyright laws and is not for resale in any manner.

FSB50450S

Motion SPM® 5 系列

特性

- 通过 UL 第 E209204 号认证 (UL1557)
- 500 V $R_{DS(on)} = 2.4 \Omega$ (最大值) FRFET MOSFET 三相逆变器, 带有栅极驱动器
- 低端 MOSFET 的三个独立开源引脚用于三相电流感测
- 高电平有效接口, 可用于 3.3 / 5 V 逻辑电平, 施密特触发脉冲输入
- 针对低电磁干扰进行优化
- 用于栅极驱动和欠压保护的 HVIC
- 绝缘等级: 1500 V_{rms} / 分钟
- 湿度敏感等级 (MSL) 3
- 符合 RoHS 标准

应用

- 小功率交流电机驱动器的三相逆变器驱动

相关资料

- [AN-9082 - Motion SPM5 Series Thermal Performance by Contact Pressure](#)
- [AN-9080 - User's Guide for Motion SPM 5 Series Ver.1](#)

概述

FSB50450S 是一款先进的 Motion SPM® 5 模块, 为交流感应、无刷直流电机和 PMSM 电机提供非常全面的高性能逆变器输出平台。这些模块综合优化了内置 MOSFET (FRFET® 技术) 的栅极驱动以最小化电磁干扰和能量损耗。内置的高速 HVIC 只需要一个单电源电压, 将逻辑电平栅极输入转化为适合驱动模块内部 MOSFET 的高电压, 高电流驱动信号。独立的开源 MOSFET 端子在每个相位均有效, 可支持大量不同种类的控制算法。



封装标识与订购信息

器件标识	器件	封装	卷尺寸	包装类型	数量
FSB50450S	FSB50450S	SPM5D-023	330 mm	卷带和卷盘	450

绝对最大额定值**逆变器部分** (单个 MOSFET, 除非另有说明。)

符号	参数	工作条件	额定值	单位
V_{DSS}	单个 MOSFET 的漏极 - 源极电压		500	V
$*I_{D25}$	单个 MOSFET 的漏极持续电流	$T_C = 25^\circ\text{C}$	1.5	A
$*I_{D80}$	单个 MOSFET 的漏极持续电流	$T_C = 80^\circ\text{C}$	1.1	A
$*I_{DP}$	单个 MOSFET 的漏极峰值电流	$T_C = 25^\circ\text{C}$, $PW < 100 \mu\text{s}$	3.0	A
$*P_D$	最大功耗	$T_C = 25^\circ\text{C}$, 单个 MOSFET	10	W

控制部分 (单个 HVIC, 除非另有说明。)

符号	参数	工作条件	额定值	单位
V_{CC}	控制电源电压	施加在 V_{CC} 和 COM 之间	20	V
V_{BS}	高端偏压	施加在 V_B 和 V_S 之间	20	V
V_{IN}	输入信号电压	施加在 IN 和 COM 之间	$-0.3 \sim V_{CC} + 0.3$	V

热阻

符号	参数	工作条件	额定值	单位
$R_{\theta JC}$	结点 - 壳体的热阻	逆变器工作条件下的单个 MOSFET (注 1)	8.9	$^\circ\text{C}/\text{W}$

整个系统

符号	参数	工作条件	额定值	单位
T_J	工作结温		$-20 \sim 150$	$^\circ\text{C}$
T_{STG}	存储温度		$-50 \sim 150$	$^\circ\text{C}$
V_{ISO}	绝缘电压	60 Hz, 正弦波形, 1 分钟, 连接陶瓷基板到引脚	1500	V_{rms}

注:

- 关于壳体温度 (T_C) 的测量点, 参见图 4。
- 标记为 “*” 的为计算值或设计因素。

引脚描述

引脚号	引脚名	引脚描述
1	COM	IC 公共电源接地
2	$V_{B(U)}$	U 相高端 MOSFET 驱动的偏压
3	$V_{CC(U)}$	U 相 IC 和低端 MOSFET 驱动的偏压
4	$IN_{(UH)}$	U 相高端的信号输入
5	$IN_{(UL)}$	U 相低端的信号输入
6	$V_{S(U)}$	U 相高端 MOSFET 驱动的偏压接地
7	$V_{B(V)}$	V 相高端 MOSFET 驱动的偏压
8	$V_{CC(V)}$	V 相 IC 和低端 MOSFET 驱动的偏压
9	$IN_{(VH)}$	V 相高端的信号输入
10	$IN_{(VL)}$	V 相低端的信号输入
11	$V_{S(V)}$	V 相高端 MOSFET 驱动的偏压接地
12	$V_{B(W)}$	W 相高端 MOSFET 驱动的偏压
13	$V_{CC(W)}$	W 相 IC 和低端 MOSFET 驱动的偏压
14	$IN_{(WH)}$	W 相高端的信号输入
15	$IN_{(WL)}$	W 相低端的信号输入
16	$V_{S(W)}$	W 相高端 MOSFET 驱动的偏压接地
17	P	直流输入正端
18	U	U 相输出
19	N_U	U 相的直流输入负端
20	N_V	V 相的直流输入负端
21	V	V 相输出
22	N_W	W 相的直流输入负端
23	W	W 相输出



图 1. 引脚布局和内部框图 (仰视图)

注:

3. 每个低端 MOSFET 的源极端子与 Motion SPM® 5 中的电源接地或偏压接地不连接。外部连接应当如图 3 所示。

电气特性 ($T_J = 25^\circ\text{C}$, $V_{CC} = V_{BS} = 15\text{V}$, 除非另有说明。)**逆变器部分** (单个 MOSFET, 除非另有说明。)

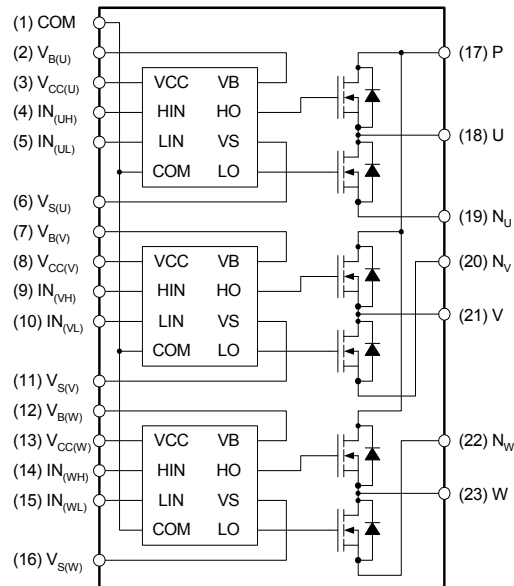
符号	参数	工作条件	最小值	典型值	最大值	单位
BV_{DSS}	漏极-源极击穿电压	$V_{IN} = 0\text{V}$, $I_D = 250\ \mu\text{A}$ (注 1)	500	-	-	V
I_{DSS}	零栅极电压漏极电流	$V_{IN} = 0\text{V}$, $V_{DS} = 500\text{V}$	-	-	250	μA
$R_{DS(on)}$	漏极至源极静态导通电阻	$V_{CC} = V_{BS} = 15\text{V}$, $V_{IN} = 5\text{V}$, $I_D = 0.5\text{A}$	-	1.9	2.4	Ω
V_{SD}	漏极-源极二极管正向电压	$V_{CC} = V_{BS} = 15\text{V}$, $V_{IN} = 0\text{V}$, $I_D = -0.5\text{A}$	-	-	1.2	V
t_{ON}	开关时间	$V_{PN} = 300\text{V}$, $V_{CC} = V_{BS} = 15\text{V}$, $I_D = 0.5\text{A}$ $V_{IN} = 0\text{V} \leftrightarrow 5\text{V}$, 电感负载 $L = 3\text{mH}$ 高端和低端 MOSFET 开关 (注 2)	-	1152	-	ns
t_{OFF}			-	600	-	ns
t_{rr}			-	185	-	ns
E_{ON}			-	85	-	μJ
E_{OFF}			-	11	-	μJ
RBSOA	反向偏压安全工作区	$V_{PN} = 400\text{V}$, $V_{CC} = V_{BS} = 15\text{V}$, $I_D = I_{DP}$, $V_{DS} = BV_{DSS}$, $T_J = 150^\circ\text{C}$ 高端和低端 MOSFET 开关 (注 3)	整个区域			

控制部分 (单个 HVIC, 除非另有说明。)

符号	参数	工作条件	最小值	典型值	最大值	单位		
I_{QCC}	V_{CC} 静态电流	$V_{CC} = 15\text{V}$, $V_{IN} = 0\text{V}$	施加在 V_{CC} 和 COM 之间		-	-	160	μA
I_{QBS}	V_{BS} 静态电流	$V_{BS} = 15\text{V}$, $V_{IN} = 0\text{V}$	施加在 $V_{B(U)} - U$, $V_{B(V)} - V$, $V_{B(W)} - W$		-	-	100	μA
UV_{CCD}	低端欠压保护 (图 8)	V_{CC} 欠压保护检测电平		7.4	8.0	9.4	V	
UV_{CCR}		V_{CC} 欠压保护复位电平		8.0	8.9	9.8	V	
UV_{BSD}	高端欠压保护 (图 9)	V_{BS} 欠压保护检测电平		7.4	8.0	9.4	V	
UV_{BSR}		V_{BS} 欠压保护复位电平		8.0	8.9	9.8	V	
V_{IH}	导通阈值电压	逻辑高电平	施加在 IN 和 COM 之间		3.0	-	-	V
V_{IL}	关断阈值电压	逻辑低电平			-	-	0.8	V
I_{IH}	输入偏置电流	$V_{IN} = 5\text{V}$		-	10	20	μA	
I_{IL}		$V_{IN} = 0\text{V}$		-	-	2	μA	

注:

- BV_{DSS} 是 Motion SPM® 5 产品中的单个 MOSFET 的漏极和源极端子之间的绝对最大额定电压。考虑到寄生电感, V_{PN} 应远低于该值, 因此 V_{PN} 在任何情况下不得超过 BV_{DSS} 。
- t_{ON} 和 t_{OFF} 包括内部驱动 IC 的传输延迟。所列出的数值是在实验室测试条件下测得, 在实际应用中因为印刷电路板和布线的差异, 数值也会有所不同。请查阅图 4 介绍的开关时间定义, 以及图 5 中的开关测试电路。
- 每个 MOSFET 在开关工作时的峰值电流和电压也应在安全工作区 (SOA) 的范围内。请查阅图 5 中的 RBSOA 测试电路, 与开关测试电路相同。

推荐工作条件

符号	参数	工作条件	最小值	典型值	最大值	单位
V_{PN}	电源电压	施加在 P 和 N 之间	-	300	400	V
V_{CC}	控制电源电压	施加在 V_{CC} 和 COM 之间	13.5	15.0	16.5	V
V_{BS}	高端偏压	施加在 V_B 和 V_S 之间	13.5	15.0	16.5	V
$V_{IN(ON)}$	输入导通阈值电压	施加在 IN 和 COM 之间	3.0	-	V_{CC}	V
$V_{IN(OFF)}$	输入关断阈值电压		0	-	0.6	V
t_{dead}	防止桥臂直通的死区时间	$V_{CC} = V_{BS} = 13.5 \sim 16.5 \text{ V}, T_J \leq 150^\circ\text{C}$	1	-	-	μs
f_{PWM}	PWM 开关频率	$T_J \leq 150^\circ\text{C}$	-	15	-	kHz
T_C	壳体温度	$T_J \leq 150^\circ\text{C}$	-20	-	100	$^\circ\text{C}$



图 2. 推荐的 MCU 接口和自举电路及其参数

注:

1. 推荐的自举二极管 D_1 具有软关断和快速恢复特性，额定电压为 600 V。
2. 自举电路的参数取决于 PWM 算法。上述为开关频率为 15 kHz 时的参数的典型例子。
3. Motion SPM 5 产品和 MCU（虚线显示部分）的每个输入端的 RC 耦合（ R_5 和 C_5 ）和 C_4 ，可用于防止由浪涌噪声产生的错误信号。
4. 印刷电路板图形中的粗线应尽量短且粗，以减少电路中的寄生电感，从而导致浪涌电压的降低。旁路电容 C_1, C_2 和 C_3 应具有良好的高频特性，以吸收高频纹波电流。

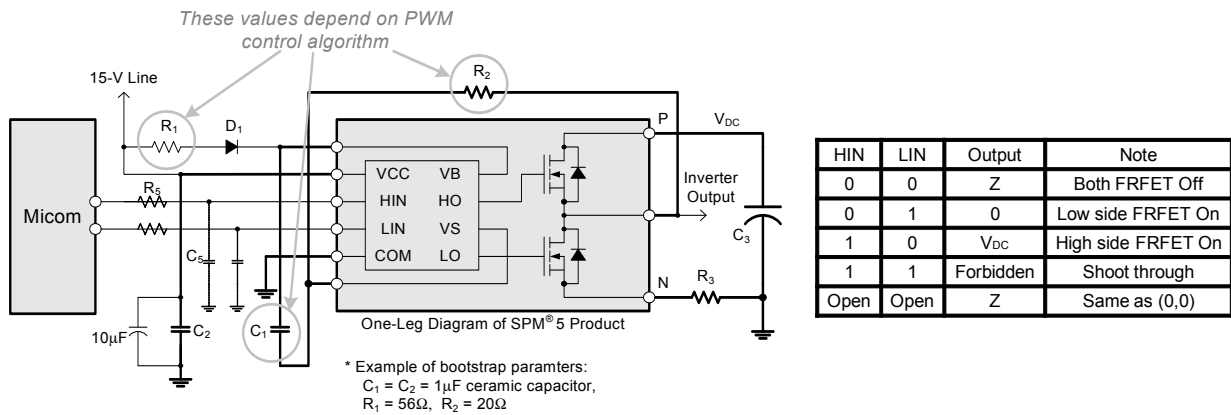

图 3. 壳体温度测量

注:

5. 将热电耦贴在 SPM 5 封装（如果应用到，放在 SPM 5 封装和散热片中间）的散热片的顶部，以获得正确的温度测量数值。

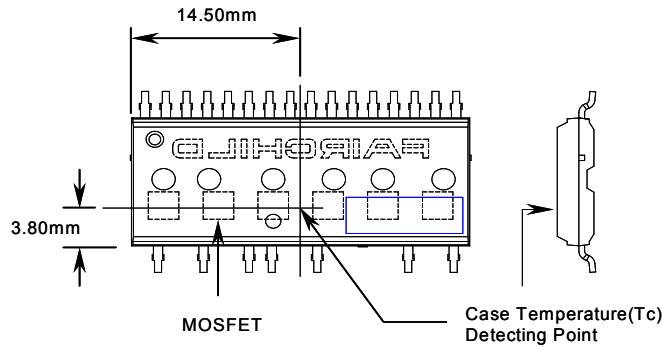

图 4. 开关时间定义



图 5. 开关和 RBSOA (单脉冲) 测试电路 (低端)

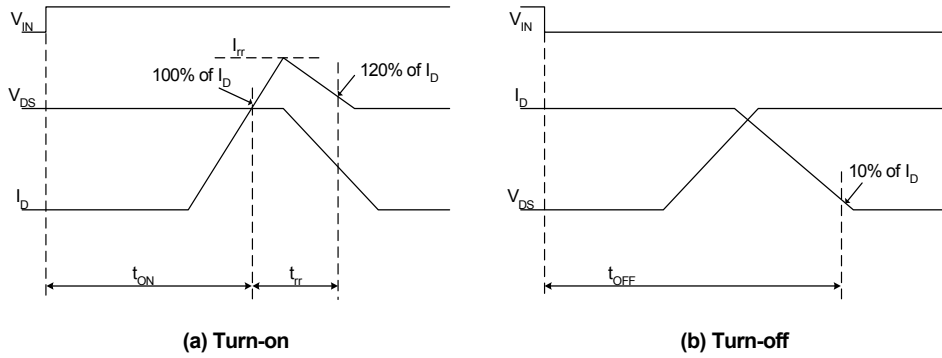

图 6. 欠压保护 (低端)

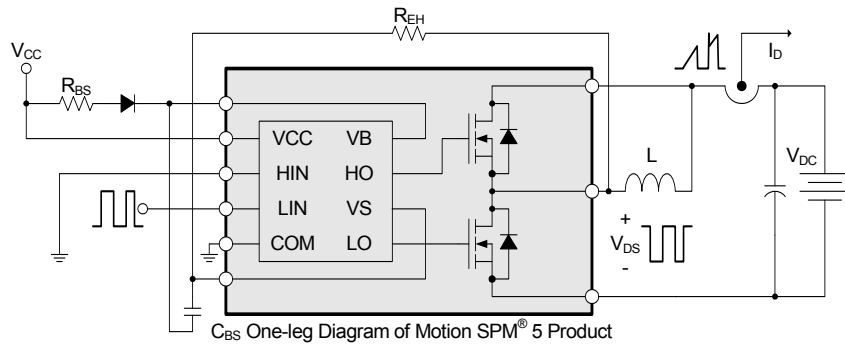

图 7. 欠压保护 (高端)

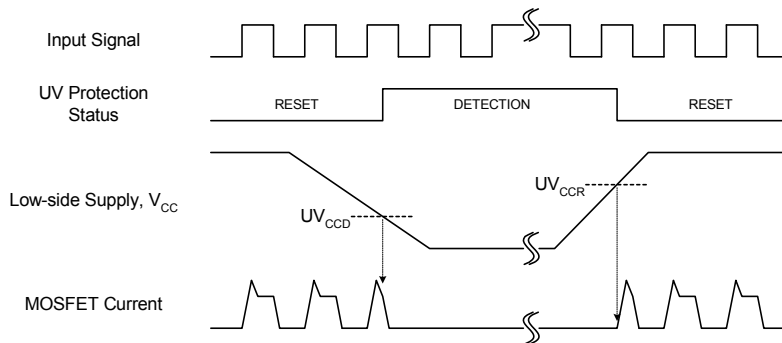

图 8. 应用电路实例

注:

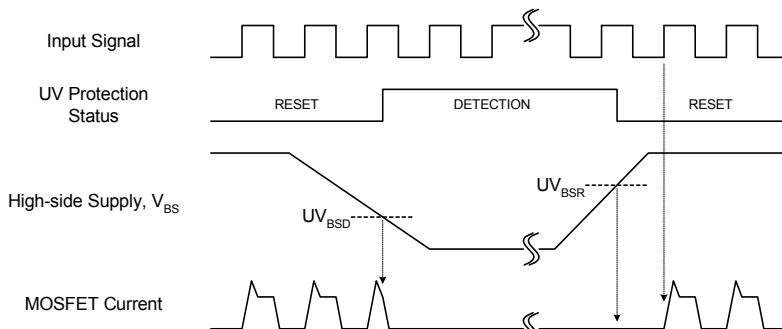
1. 关于引脚的位置, 请参阅图 1。
2. Motion SPM® 5 产品和 MCU 的每个输入端的 RC 耦合 (R_5 和 C_5 , R_4 和 C_6) 和 C_4 , 能有效的防止由浪涌噪声产生的错误的输入信号。
3. 由于位于 COM 和低端 MOSFET 的源极端子之间, R_3 的压降会影响低端的开关性能和自举特性。为此, 稳态情况下 R_3 的压降应小于 1 V。
4. 为避免浪涌电压和 HVIC 故障, 接地线和输出端子之间的接线应短且粗。
5. 所有的滤波电容器应紧密连接到 Motion SPM 5 产品, 它们应当具有能够很好的阻挡高频纹波电流的特性。

封装轮廓详图

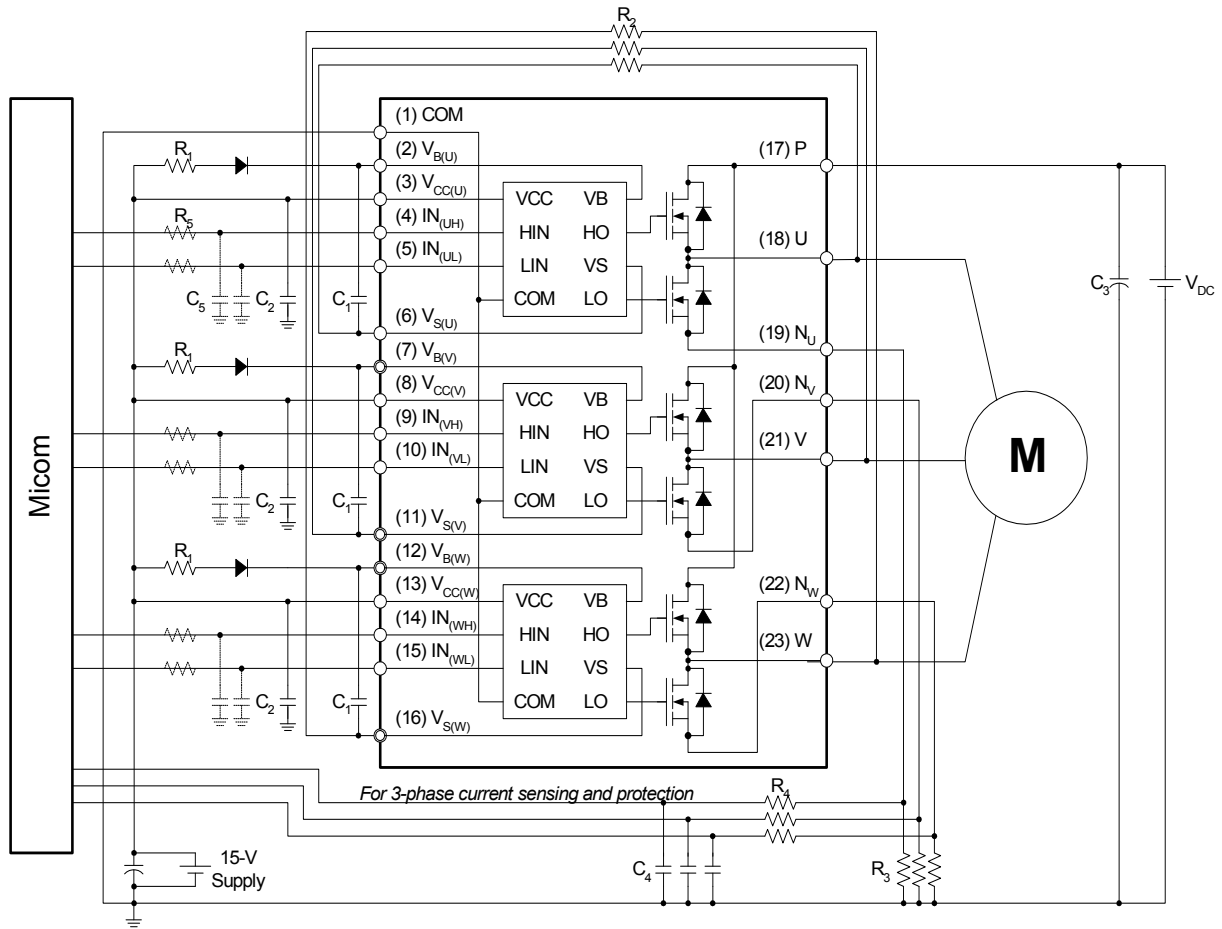
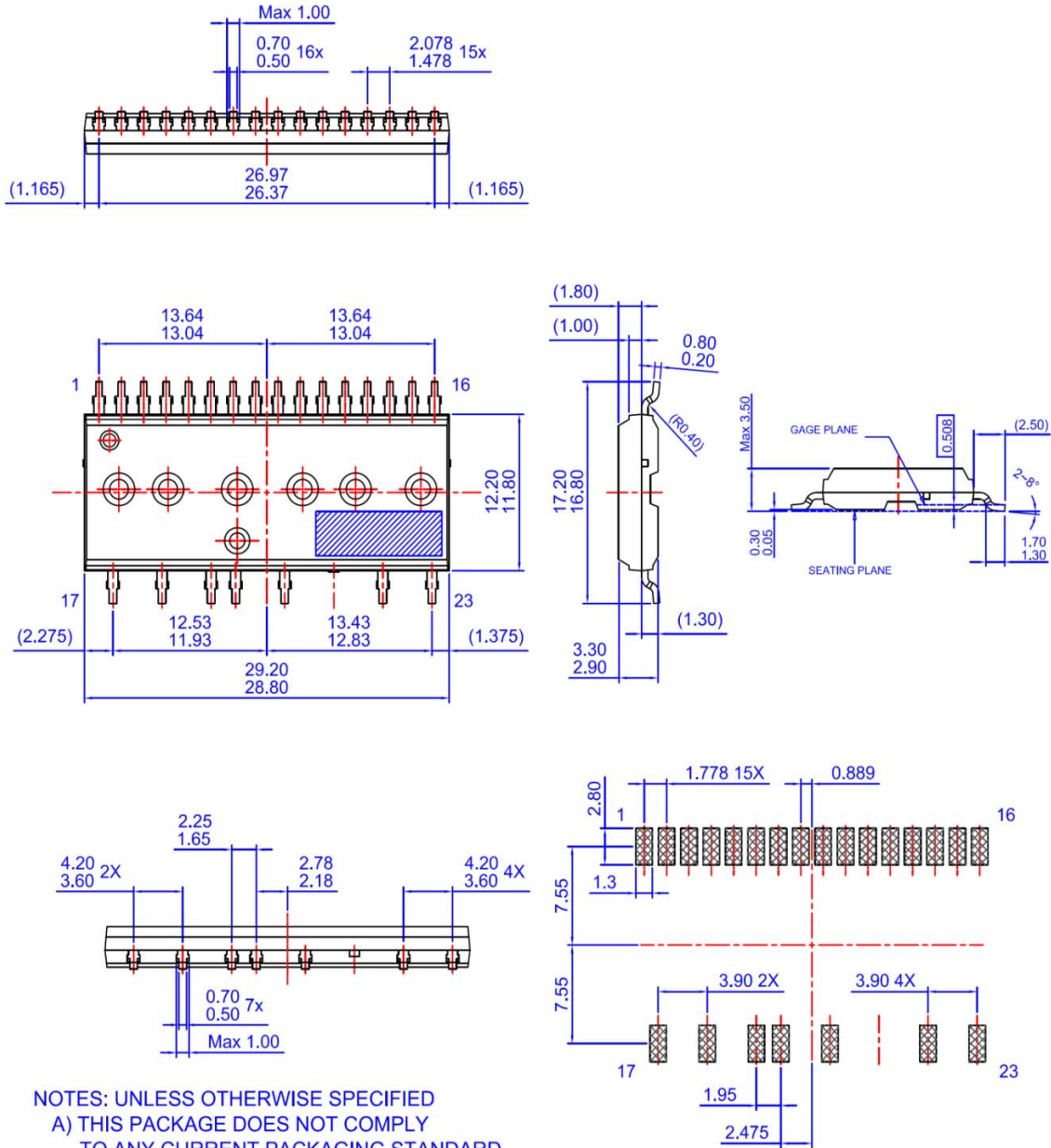

LAND PATTERN RECOMMENDATIONS

- NOTES: UNLESS OTHERWISE SPECIFIED
 A) THIS PACKAGE DOES NOT COMPLY TO ANY CURRENT PACKAGING STANDARD
 B) ALL DIMENSIONS ARE IN MILLIMETERS
 C) DIMENSIONS ARE EXCLUSIVE OF BURRS, MOLD FLASH, AND TIE BAR EXTRUSIONS
 D) () IS REFERENCE
 E) [] IS ASSY QUALITY
 F) DRAWING FILENAME: MOD23DEREV3.0
 G) FAIRCHILD SEMICONDUCTOR

封装图纸作为一项服务，提供给考虑飞兆半导体元件的客户。具体参数可能会有变化，且不会做出相应通知。请注意图纸上的版本和 / 或日期，并联系飞兆半导体代表核实或获得最新版本。封装规格并不扩大飞兆公司全球范围内的条款与条件，尤其是其中涉及飞兆公司产品保修的部分。





随时访问飞兆半导体在线封装网页，可以获取最新的封装图纸：

<http://www.fairchildsemi.com/dwg/MO/MOD23DE.pdf>



TRADEMARKS

The following includes registered and unregistered trademarks and service marks, owned by Fairchild Semiconductor and/or its global subsidiaries, and is not intended to be an exhaustive list of all such trademarks.

- | | | | |
|---|--|---|---|
| AccuPower™ | F-PFS™ |  | Sync-Lock™ |
| AX-CAP®* | FRFET® | PowerTrench® |  SYSTEM GENERAL® |
| BitSiC™ | Global Power Resource™ | PowerXS™ | TinyBoost® |
| Build it Now™ | GreenBridge™ | Programmable Active Droop™ | TinyBuck® |
| CorePLUS™ | Green FPS™ | QFET® | TinyCalc™ |
| CorePOWER™ | Green FPS™ e-Series™ | QS™ | TinyLogic® |
| CROSSVOLT™ | Gmax™ | Quiet Series™ | TINYOPTO™ |
| CTL™ | GTO™ | RapidConfigure™ | TinyPower™ |
| Current Transfer Logic™ | IntelliMAX™ |  Saving our world, 1mW/W/kW at a time™ | TinyPWM™ |
| DEUXPEED® | ISOPLANAR™ | SignalWise™ | TinyWire™ |
| Dual Cool™ | Making Small Speakers Sound Louder and Better™ | SmartMax™ | TranSiC™ |
| EcoSPARK® | MegaBuck™ | SMART START™ | TriFault Detect™ |
| EfficientMax™ | MICROCOUPLER™ | Solutions for Your Success™ | TRUECURRENT®* |
| ESBC™ | MicroFET™ | SPM® |  SerDes® |
|  | MicroPak™ | STEALTH™ | UHC® |
| Fairchild® | MicroPak2™ | SuperFET® | Ultra FRFET™ |
| Fairchild Semiconductor® | MillerDrive™ | SuperSOT™-3 | UniFET™ |
| FACT Quiet Series™ | MotionMax™ | SuperSOT™-6 | VCX™ |
| FACT® | mWSaver® | SuperSOT™-8 | VisualMax™ |
| FAST® | OptoHiT™ | SupreMOS® | VoltagePlus™ |
| FastvCore™ | OPTOLOGIC® | SyncFET™ | XS™ |
| FETBench™ | OPTOPLANAR® | | |
| FPS™ | | | |

* Trademarks of System General Corporation, used under license by Fairchild Semiconductor.

DISCLAIMER

FAIRCHILD SEMICONDUCTOR RESERVES THE RIGHT TO MAKE CHANGES WITHOUT FURTHER NOTICE TO ANY PRODUCTS HEREIN TO IMPROVE RELIABILITY, FUNCTION, OR DESIGN. FAIRCHILD DOES NOT ASSUME ANY LIABILITY ARISING OUT OF THE APPLICATION OR USE OF ANY PRODUCT OR CIRCUIT DESCRIBED HEREIN; NEITHER DOES IT CONVEY ANY LICENSE UNDER ITS PATENT RIGHTS, NOR THE RIGHTS OF OTHERS. THESE SPECIFICATIONS DO NOT EXPAND THE TERMS OF FAIRCHILD'S WORLDWIDE TERMS AND CONDITIONS, SPECIFICALLY THE WARRANTY THEREIN, WHICH COVERS THESE PRODUCTS.

LIFE SUPPORT POLICY

FAIRCHILD'S PRODUCTS ARE NOT AUTHORIZED FOR USE AS CRITICAL COMPONENTS IN LIFE SUPPORT DEVICES OR SYSTEMS WITHOUT THE EXPRESS WRITTEN APPROVAL OF FAIRCHILD SEMICONDUCTOR CORPORATION.

As used herein:

1. Life support devices or systems are devices or systems which, (a) are intended for surgical implant into the body or (b) support or sustain life, and (c) whose failure to perform when properly used in accordance with instructions for use provided in the labeling, can be reasonably expected to result in a significant injury of the user.
2. A critical component in any component of a life support, device, or system whose failure to perform can be reasonably expected to cause the failure of the life support device or system, or to affect its safety or effectiveness.

ANTI-COUNTERFEITING POLICY

Fairchild Semiconductor Corporation's Anti-Counterfeiting Policy. Fairchild's Anti-Counterfeiting Policy is also stated on our external website, www.fairchildsemi.com, under Sales Support.

Counterfeiting of semiconductor parts is a growing problem in the industry. All manufacturers of semiconductor products are experiencing counterfeiting of their parts. Customers who inadvertently purchase counterfeit parts experience many problems such as loss of brand reputation, substandard performance, failed applications, and increased cost of production and manufacturing delays. Fairchild is taking strong measures to protect ourselves and our customers from the proliferation of counterfeit parts. Fairchild strongly encourages customers to purchase Fairchild parts either directly from Fairchild or from Authorized Fairchild Distributors who are listed by country on our web page cited above. Products customers buy either from Fairchild directly or from Authorized Fairchild Distributors are genuine parts, have full traceability, meet Fairchild's quality standards for handling and storage and provide access to Fairchild's full range of up-to-date technical and product information. Fairchild and our Authorized Distributors will stand behind all warranties and will appropriately address any warranty issues that may arise. Fairchild will not provide any warranty coverage or other assistance for parts bought from Unauthorized Sources. Fairchild is committed to combat this global problem and encourage our customers to do their part in stopping this practice by buying direct or from authorized distributors.

PRODUCT STATUS DEFINITIONS

Definition of Terms

Datasheet Identification	Product Status	Definition
Advance Information	Formative / In Design	Datasheet contains the design specifications for product development. Specifications may change in any manner without notice.
Preliminary	First Production	Datasheet contains preliminary data; supplementary data will be published at a later date. Fairchild Semiconductor reserves the right to make changes at any time without notice to improve design.
No Identification Needed	Full Production	Datasheet contains final specifications. Fairchild Semiconductor reserves the right to make changes at any time without notice to improve the design.
Obsolete	Not In Production	Datasheet contains specifications on a product that is discontinued by Fairchild Semiconductor. The datasheet is for reference information only.

Rev. 166

ON Semiconductor and  are trademarks of Semiconductor Components Industries, LLC dba ON Semiconductor or its subsidiaries in the United States and/or other countries. ON Semiconductor owns the rights to a number of patents, trademarks, copyrights, trade secrets, and other intellectual property. A listing of ON Semiconductor's product/patent coverage may be accessed at www.onsemi.com/site/pdf/Patent-Marking.pdf. ON Semiconductor reserves the right to make changes without further notice to any products herein. ON Semiconductor makes no warranty, representation or guarantee regarding the suitability of its products for any particular purpose, nor does ON Semiconductor assume any liability arising out of the application or use of any product or circuit, and specifically disclaims any and all liability, including without limitation special, consequential or incidental damages. Buyer is responsible for its products and applications using ON Semiconductor products, including compliance with all laws, regulations and safety requirements or standards, regardless of any support or applications information provided by ON Semiconductor. "Typical" parameters which may be provided in ON Semiconductor data sheets and/or specifications can and do vary in different applications and actual performance may vary over time. All operating parameters, including "Typicals" must be validated for each customer application by customer's technical experts. ON Semiconductor does not convey any license under its patent rights nor the rights of others. ON Semiconductor products are not designed, intended, or authorized for use as a critical component in life support systems or any FDA Class 3 medical devices or medical devices with a same or similar classification in a foreign jurisdiction or any devices intended for implantation in the human body. Should Buyer purchase or use ON Semiconductor products for any such unintended or unauthorized application, Buyer shall indemnify and hold ON Semiconductor and its officers, employees, subsidiaries, affiliates, and distributors harmless against all claims, costs, damages, and expenses, and reasonable attorney fees arising out of, directly or indirectly, any claim of personal injury or death associated with such unintended or unauthorized use, even if such claim alleges that ON Semiconductor was negligent regarding the design or manufacture of the part. ON Semiconductor is an Equal Opportunity/Affirmative Action Employer. This literature is subject to all applicable copyright laws and is not for resale in any manner.

PUBLICATION ORDERING INFORMATION

LITERATURE FULFILLMENT:

Literature Distribution Center for ON Semiconductor
19521 E. 32nd Pkwy, Aurora, Colorado 80011 USA
Phone: 303-675-2175 or 800-344-3860 Toll Free USA/Canada
Fax: 303-675-2176 or 800-344-3867 Toll Free USA/Canada
Email: orderlit@onsemi.com

N. American Technical Support: 800-282-9855 Toll Free
USA/Canada
Europe, Middle East and Africa Technical Support:
Phone: 421 33 790 2910
Japan Customer Focus Center
Phone: 81-3-5817-1050

ON Semiconductor Website: www.onsemi.com
Order Literature: <http://www.onsemi.com/orderlit>
For additional information, please contact your local
Sales Representative