



Is Now Part of



ON Semiconductor®

To learn more about ON Semiconductor, please visit our website at
www.onsemi.com

Please note: As part of the Fairchild Semiconductor integration, some of the Fairchild orderable part numbers will need to change in order to meet ON Semiconductor's system requirements. Since the ON Semiconductor product management systems do not have the ability to manage part nomenclature that utilizes an underscore (_), the underscore (_) in the Fairchild part numbers will be changed to a dash (-). This document may contain device numbers with an underscore (_). Please check the ON Semiconductor website to verify the updated device numbers. The most current and up-to-date ordering information can be found at www.onsemi.com. Please email any questions regarding the system integration to Fairchild_questions@onsemi.com.

ON Semiconductor and the ON Semiconductor logo are trademarks of Semiconductor Components Industries, LLC dba ON Semiconductor or its subsidiaries in the United States and/or other countries. ON Semiconductor owns the rights to a number of patents, trademarks, copyrights, trade secrets, and other intellectual property. A listing of ON Semiconductor's product/patent coverage may be accessed at www.onsemi.com/site/pdf/Patent-Marking.pdf. ON Semiconductor reserves the right to make changes without further notice to any products herein. ON Semiconductor makes no warranty, representation or guarantee regarding the suitability of its products for any particular purpose, nor does ON Semiconductor assume any liability arising out of the application or use of any product or circuit, and specifically disclaims any and all liability, including without limitation special, consequential or incidental damages. Buyer is responsible for its products and applications using ON Semiconductor products, including compliance with all laws, regulations and safety requirements or standards, regardless of any support or applications information provided by ON Semiconductor. "Typical" parameters which may be provided in ON Semiconductor data sheets and/or specifications can and do vary in different applications and actual performance may vary over time. All operating parameters, including "Typicals" must be validated for each customer application by customer's technical experts. ON Semiconductor does not convey any license under its patent rights nor the rights of others. ON Semiconductor products are not designed, intended, or authorized for use as a critical component in life support systems or any FDA Class 3 medical devices or medical devices with a same or similar classification in a foreign jurisdiction or any devices intended for implantation in the human body. Should Buyer purchase or use ON Semiconductor products for any such unintended or unauthorized application, Buyer shall indemnify and hold ON Semiconductor and its officers, employees, subsidiaries, affiliates, and distributors harmless against all claims, costs, damages, and expenses, and reasonable attorney fees arising out of, directly or indirectly, any claim of personal injury or death associated with such unintended or unauthorized use, even if such claim alleges that ON Semiconductor was negligent regarding the design or manufacture of the part. ON Semiconductor is an Equal Opportunity/Affirmative Action Employer. This literature is subject to all applicable copyright laws and is not for resale in any manner.

FSBB30CH60F

Motion SPM® 3 系列

特性

- 通过 UL 第 E209204 号认证 (UL1557)
- 600 V - 30 A 三相 IGBT 逆变器, 包含栅极驱动和保护的控制 IC
- 内置过热关断功能
- 低损耗、短路额定的 IGBT
- 采用 DBC (A1N) 基板实现非常低的热阻
- 专用的 Vs 引脚以简化印刷电路板布局
- 低端 IGBT 的独立发射极开路引脚用于三相电流感测
- 单接地电源供电
- 绝缘等级: 2500 V_{rms} / 分钟

应用

- 运动控制 - 家用设备 / 工业电机

相关资料

- [AN-9035 - Motion SPM 3 Series Ver.2 User's Guide](#)

概述

FSBB30CH60F 是一款 SPM® 3 模块, 为交流感应、无刷直流电机和 PMSM 电机提供非常全面的高性能逆变器输出平台。这些模块综合优化了内置 IGBT 的栅极驱动以最小化电磁干扰和能量损耗。同时也提供多重模组保护特性, 集成欠压闭锁, 过流保护和故障报告。内置的高速 HVIC 只需要一个单电源电压, 将逻辑电平栅极输入转化为适合驱动模块内部 IGBT 的高电压, 高电流驱动信号。独立的 IGBT 负端在每个相位均有效, 可支持大量不同种类的控制算法。



图 1. 封装概览

封装标识与订购信息

器件	器件标识	封装	包装类型	数量
FSBB30CH60F	FSBB30CH60F	SPMEA-027	Rail	10

集成的功率功能

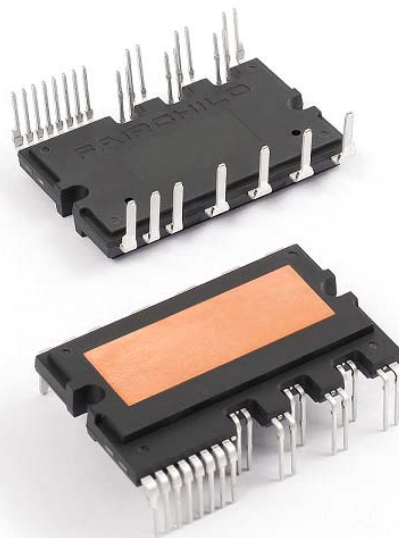
- 600 V - 30 A IGBT 逆变器，适用于三相 DC / AC 功率转换（请参阅图 3）

集成的驱动、保护和系统控制功能

- 对于逆变器高端 IGBT：栅极驱动电路、高压隔离的高速电平转换控制电路欠压锁定保护 (UVLO)
注：可用自举电路示例如图 10 和图 11 所示。
- 对于逆变器低端 IGBT：栅极驱动电路、短路保护 (SCP)、控制电源欠压锁定保护 (UVLO)
- 故障信号：对应 UVLO（低端电源）和短路故障
- 输入接口：高电平有效接口，可用于 3.3 / 5 V 逻辑电平，施密特触发脉冲输入

引脚布局



图 2. 俯视图

引脚描述

引脚号	引脚名	引脚描述
1	$V_{CC(L)}$	IC 和 IGBT 驱动的低端公共偏压
2	COM	公共电源接地
3	$IN_{(UL)}$	低端 U 相的信号输入
4	$IN_{(VL)}$	低端 V 相的信号输入
5	$IN_{(WL)}$	低端 W 相的信号输入
6	V_{FO}	故障输出
7	C_{FOD}	设置故障输出持续时间的电容
8	C_{SC}	短路电流感测输入电容（低通滤波器）
9	$IN_{(UH)}$	高端 U 相的信号输入
10	$V_{CC(UH)}$	U 相 IC 的高端偏压
11	$V_{B(U)}$	U 相 IGBT 驱动的高端偏压
12	$V_{S(U)}$	U 相 IGBT 驱动的高端偏压接地
13	$IN_{(VH)}$	高端 V 相的信号输入
14	$V_{CC(VH)}$	V 相 IC 的高端偏压
15	$V_{B(V)}$	V 相 IGBT 驱动的高端偏压
16	$V_{S(V)}$	V 相 IGBT 驱动的高端偏压接地
17	$IN_{(WH)}$	高端 W 相的信号输入
18	$V_{CC(WH)}$	W 相 IC 的高端偏压
19	$V_{B(W)}$	W 相 IGBT 驱动的高端偏压
20	$V_{S(W)}$	W 相 IGBT 驱动的高端偏压接地
21	N_U	U 相的直流输入负端
22	N_V	V 相的直流输入负端
23	N_W	W 相的直流输入负端
24	U	U 相输出
25	V	V 相输出
26	W	W 相输出
27	P	直流输入正端

内部等效电路与输入 / 输出引脚

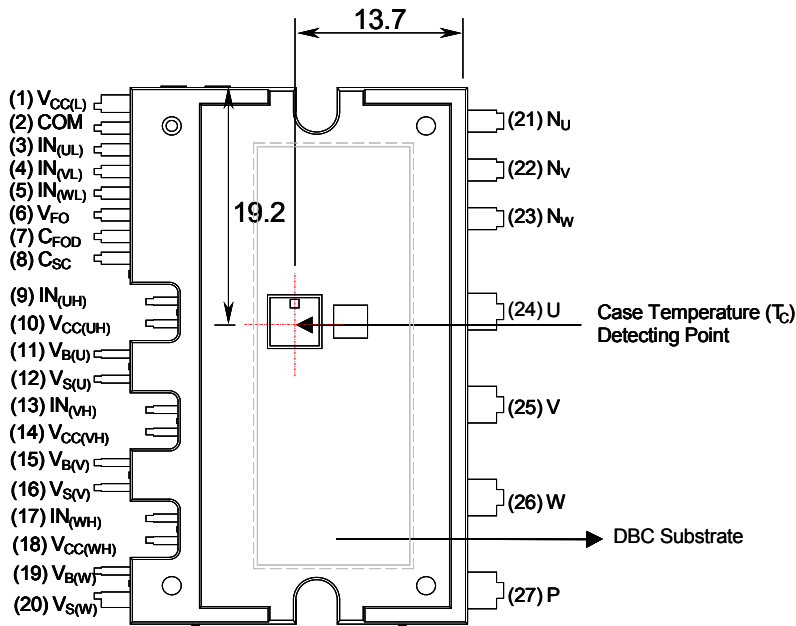

图 3. 内部框图

注:

1. 逆变器的低端由三个 IGBT 及相应的续流二极管和一个控制 IC 组成。具有栅极驱动和保护功能。
2. 逆变器的功率端由逆变器的四个直流母线输入端和三个输出端组成。
3. 逆变器高端由三个 IGBT 以及相应的续流二极管和驱动 IC 组成。

绝对最大额定值 ($T_J = 25^\circ\text{C}$, 除非另有说明。)**逆变器部分**

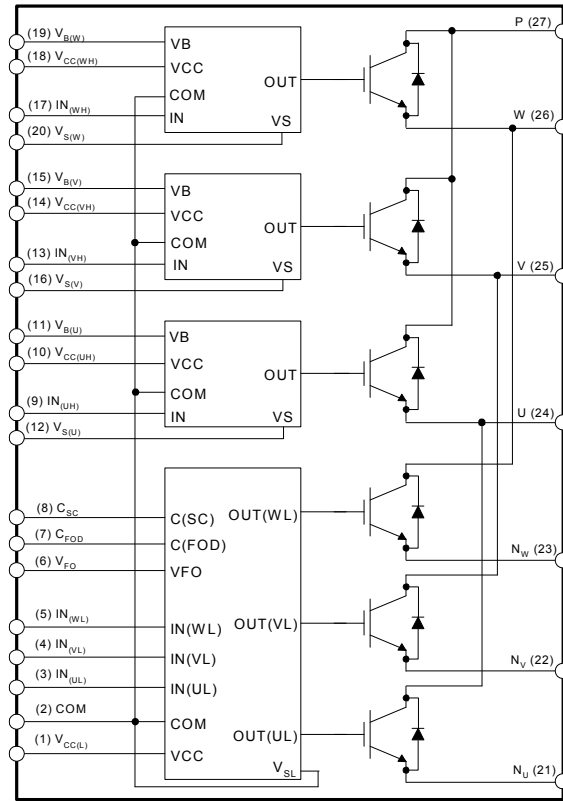
符号	参数	工作条件	额定值	单位
V_{PN}	电源电压	施加在 P- N_U , N_V , N_W	450	V
V_{PN} (浪涌)	电源电压 (浪涌)	施加在 P- N_U , N_V , N_W	500	V
V_{CES}	集电极 - 发射极之间电压		600	V
$\pm I_C$	单个 IGBT 的集电极电流	$T_C = 25^\circ\text{C}$	30	A
$\pm I_{CP}$	单个 IGBT 的集电极电流 (峰值)	$T_C = 25^\circ\text{C}$, 脉冲宽度小于 1 ms	45	A
P_C	集电极功耗	$T_C = 25^\circ\text{C}$, 单个芯片	103	W
T_J	工作结温	(注 1)	-20 ~ 125	$^\circ\text{C}$

注:

1. Motion SPM® 3 产品中集成的功率芯片的最大结温额定值为 150°C (当 $T_C \leq 100^\circ\text{C}$)。但是, 为保证 Motion SPM 3 产品的安全工作, 平均结温应限制为 $T_{J(\text{ave})} \leq 125^\circ\text{C}$ (at $T_C \leq 100^\circ\text{C}$)

控制部分

符号	参数	工作条件	额定值	单位
V_{CC}	控制电源电压	施加在 $V_{CC(UH)}$, $V_{CC(VH)}$, $V_{CC(WH)}$, $V_{CC(L)}$ - COM	20	V
V_{BS}	高端控制偏置电压	施加在 $V_{B(U)}$ - $V_{S(U)}$, $V_{B(V)}$ - $V_{S(V)}$, $V_{B(W)}$ - $V_{S(W)}$	20	V
V_{IN}	输入信号电压	施加在 $IN_{(UH)}$, $IN_{(VH)}$, $IN_{(WH)}$, $IN_{(UL)}$, $IN_{(VL)}$, $IN_{(WL)}$ - COM 之间	-0.3 ~ 17	V
V_{FO}	故障输出电源电压	施加在 V_{FO} - COM 之间	-0.3 ~ $V_{CC}+0.3$	V
I_{FO}	故障输出电流	V_{FO} 引脚处的灌电流	5	mA
V_{SC}	电流感测输入电压	施加在 C_{SC} - COM 之间	-0.3 ~ $V_{CC}+0.3$	V

整个系统

符号	参数	工作条件	额定值	单位
$V_{PN(\text{PROT})}$	自我保护电源电压限制 (短路保护能力)	$V_{CC} = V_{BS} = 13.5 \sim 16.5 \text{ V}$ $T_J = 125^\circ\text{C}$, 非重复性, 小于 $< 2 \mu\text{s}$	400	V
T_C	模块壳体工作温度	$-20^\circ\text{C} \leq T_J \leq 125^\circ\text{C}$, 见图 2	-20 ~ 100	$^\circ\text{C}$
T_{STG}	存储温度		-40 ~ 125	$^\circ\text{C}$
V_{ISO}	绝缘电压	60 Hz, 正弦波形, 交流 1 分钟, 连接陶瓷基板到引脚	2500	V_{rms}

热阻

符号	参数	条件	最小值	典型值	最大值	单位
$R_{th(j-c)Q}$	结点 - 壳体的热阻	逆变器 IGBT 部分 (每 1 / 6 模块)	-	-	0.97	$^\circ\text{C/W}$
$R_{th(j-c)F}$		逆变器 FWD 部分 (每 1 / 6 模块)	-	-	1.77	$^\circ\text{C/W}$

注:

2. 关于壳体温度 (T_C) 的测量点, 请参见图 2。

电气特性 ($T_J = 25^\circ\text{C}$, 除非另有说明。)

逆变器部分

符号	参数	工作条件		最小值	典型值	最大值	单位	
$V_{CE(SAT)}$	集电极 - 发射极间饱和电压	$V_{CC} = V_{BS} = 15\text{ V}$ $V_{IN} = 5\text{ V}$	$I_C = 30\text{ A}$, $T_J = 25^\circ\text{C}$	-	-	2.75	V	
V_F	FWD 正向电压	$V_{IN} = 0\text{ V}$	$I_C = 30\text{ A}$, $T_J = 25^\circ\text{C}$	-	-	2.4	V	
HS	t_{ON}	开关时间	$V_{PN} = 300\text{ V}$, $V_{CC} = V_{BS} = 15\text{ V}$ $I_C = 30\text{ A}$ $V_{IN} = 0\text{ V} \leftrightarrow 5\text{ V}$, 电感负载 (注 3)	-	0.49	-	μs	
				$t_{C(ON)}$	-	0.34	-	μs
				t_{OFF}	-	0.86	-	μs
				$t_{C(OFF)}$	-	0.52	-	μs
				t_{rr}	-	0.10	-	μs
LS	t_{ON}	开关时间	$V_{PN} = 300\text{ V}$, $V_{CC} = V_{BS} = 15\text{ V}$ $I_C = 30\text{ A}$ $V_{IN} = 0\text{ V} \leftrightarrow 5\text{ V}$, 电感负载 (注 3)	-	0.68	-	μs	
				$t_{C(ON)}$	-	0.47	-	μs
				t_{OFF}	-	0.90	-	μs
				$t_{C(OFF)}$	-	0.50	-	μs
				t_{rr}	-	0.10	-	μs
I_{CES}	集电极 - 发射极间漏电流	$V_{CE} = V_{CES}$		-	-	250	μA	

注:

3. t_{ON} 和 t_{OFF} 包括模块内部驱动 IC 的传输延迟时间。 $t_{C(ON)}$ 和 $t_{C(OFF)}$ 指在内部给定的栅极驱动条件下, IGBT 本身的开关时间。详细信息, 请参见图 4。



图 4. 开关时间的定义

电气特性 (T_J = 25°C, 除非另有说明。)

控制部分

符号	参数	工作条件	最小值	典型值	最大值	单位
I _{QCCL}	V _{CC} 静态电源电流	V _{CC} = 15 V I _{N(U_L, V_L, W_L)} = 0 V	V _{CC(L)} - COM	-	-	23 mA
I _{QCCH}		V _{CC} = 15 V I _{N(U_H, V_H, W_H)} = 0 V	V _{CC(U_H)} , V _{CC(V_H)} , V _{CC(W_H)} - COM	-	-	100 μA
I _{QBS}	V _{BS} 静态电源电流	V _{BS} = 15 V I _{N(U_H, V_H, W_H)} = 0 V	V _{B(U)} - V _{S(U)} , V _{B(V)} - V _{S(V)} , V _{B(W)} - V _{S(W)}	-	-	500 μA
V _{FOH}	故障输出电压	V _{SC} = 0 V, V _{FO} 电路: 4.7 kΩ 至 5 V 上拉	4.5	-	-	V
V _{FOL}		V _{SC} = 1 V, V _{FO} 电路: 4.7 kΩ 至 5 V 上拉	-	-	0.8	V
V _{SC(ref)}	短路电流触发电平	V _{CC} = 15 V (注 4)	0.45	0.50	0.55	V
TSD	过温保护	LVIC 的温度	125	145	175	°C
Δ TSD	过温保护迟滞	LVIC 的温度	-	18	-	°C
UV _{CCD}	电源电路欠压保护	检测电平	10.7	11.9	13.0	V
UV _{CCR}		复位电平	11.2	12.4	13.2	V
UV _{BSD}		检测电平	10.1	11.3	12.5	V
UV _{BSR}		复位电平	10.5	11.7	12.9	V
t _{FOD}	故障输出脉宽	C _{FOD} = 33 nF (注 5)	1.0	1.8	-	ms
V _{IN(ON)}	导通阈值电压	施加在 I _{N(U_H)} , I _{N(V_H)} , I _{N(W_H)} , I _{N(U_L)} , I _{N(V_L)} , I _{N(W_L)} - COM 之间	3.0	-	-	V
V _{IN(OFF)}	关断阈值电压		-	-	0.8	V

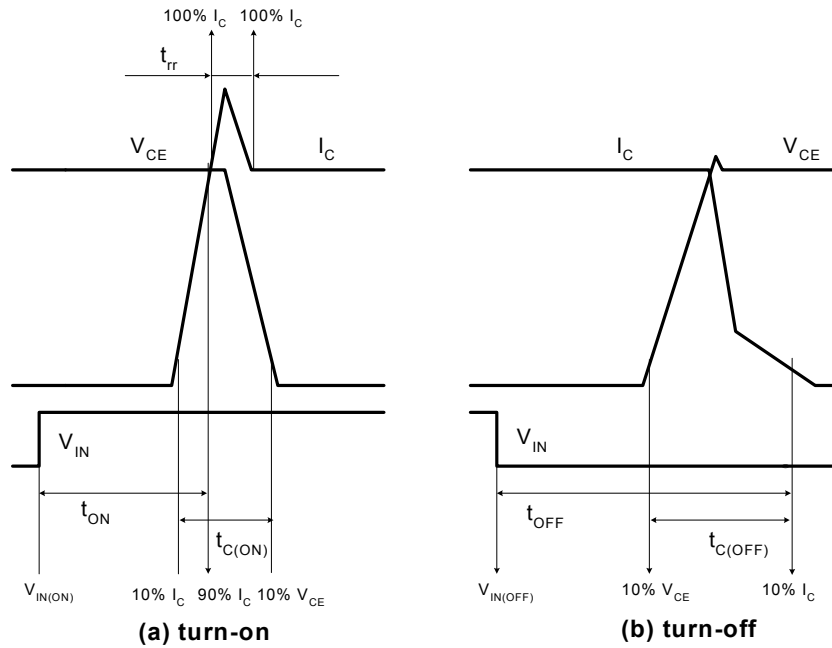
注:

4. 短路电流保护仅作用于低端。

5. 故障输出脉宽 t_{FOD} 取决于电容 C_{FOD} 的值, 可采用下面的近似公式进行计算: C_{FOD} = 18.3 × 10⁻⁶ × t_{FOD} [F]

推荐工作条件

符号	参数	工作条件	最小值	典型值	最大值	单位
V _{PN}	电源电压	施加在 P - N _U , N _V , N _W 之间	-	300	400	V
V _{CC}	控制电源电压	施加在 V _{CC(U_H)} , V _{CC(V_H)} , V _{CC(W_H)} , V _{CC(L)} - COM	13.5	-	16.5	V
V _{BS}	高端偏压	施加在 V _{B(U)} - V _{S(U)} , V _{B(V)} - V _{S(V)} , V _{B(W)} - V _{S(W)}	13	-	18.5	V
dV _{CC} / dt, dV _{BS} / dt	控制电源波动		-1	-	1	V / μs
t _{dead}	防止桥臂直通的死区时间	适用于每个输入信号	2.5	-	-	μs
f _{PWM}	PWM 输入信号	-20°C ≤ T _C ≤ 100°C, -20°C ≤ T _J ≤ 125°C	-	-	20	kHz
V _{SEN}	电流感测产生的电压	施加在 N _U , N _V , N _W - COM 之间 (包括浪涌电压)	-4		4	V

机械特性和额定值

参数	工作条件		最小值	典型值	最大值	单位
安装扭矩	安装螺钉: M3	建议 0.62 N•m	0.51	0.62	0.72	N•m
器件平面度		见图 5	0	-	+120	μm
重量			-	15.00	-	g



图 5. 平面度测量位置

保护功能时序图

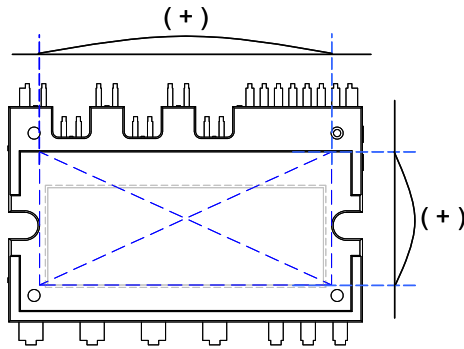
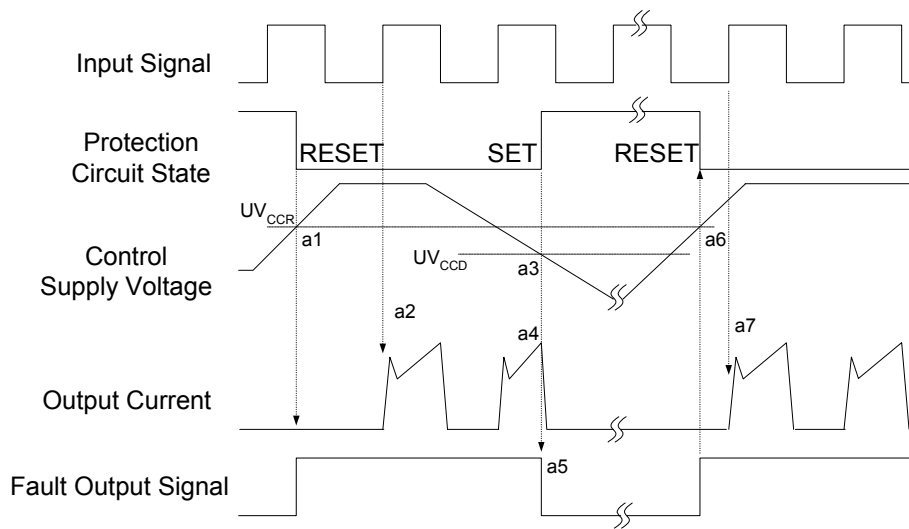

- a1: 控制电源电压上升: 当电压上升到 UV_{CCR} 后, 等到下一个开通信号时, 对应的电路才开始动作。
- a2: 正常工作: IGBT 导通并加载负载电流。
- a3: 欠压检测 (UV_{CCD})。
- a4: 不论控制输入的条件, IGBT 都关断。
- a5: 故障输出工作启动。
- a6: 欠压复位 (UV_{CCR})。
- a7: 正常工作: IGBT 导通并加载负载电流。

图 6. 欠压保护 (低端)

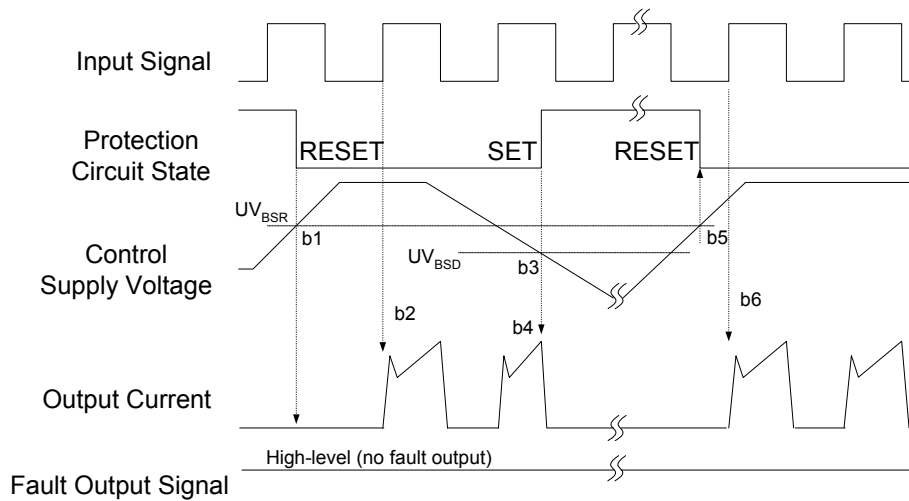

- b1: 控制电源电压上升: 当电压上升到 UV_{BSR} 后, 等到下一个输入信号时, 对应的电路才开始动作。
- b2: 正常工作: IGBT 导通并加载负载电流。
- b3: 欠压检测 (UV_{BSD})。
- b4: 不论控制输入的条件, IGBT 都关闭, 且无故障输出信号。
- b5: 欠压复位 (UV_{BSR})。
- b6: 正常工作: IGBT 导通并加载负载电流。

图 7. 欠压保护 (高端)

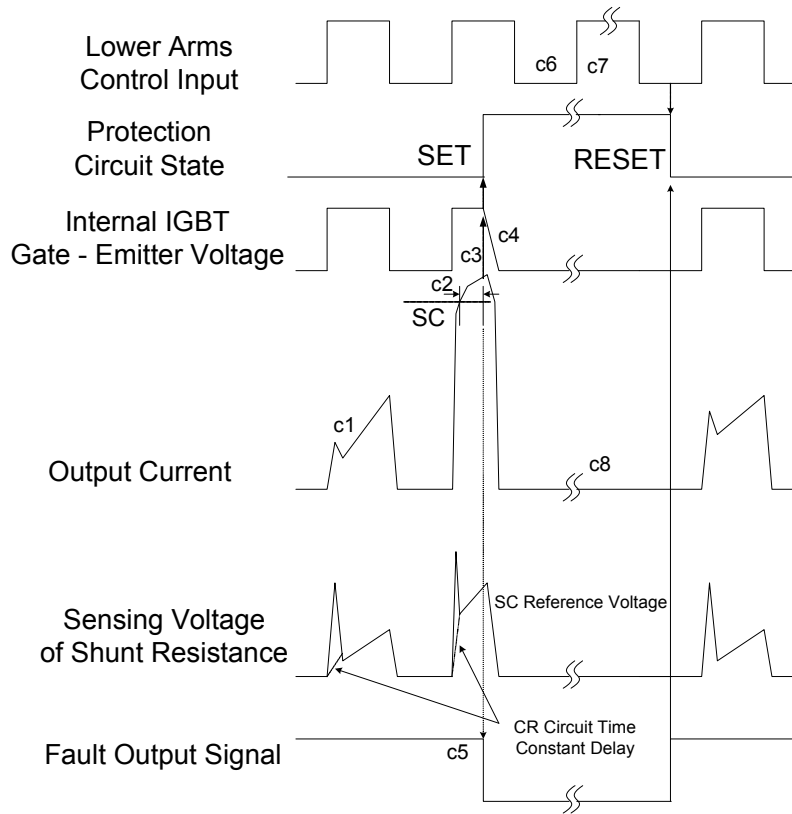

(包含外部分流电阻和 CR 连接)

- c1 : 正常工作: IGBT 导通并加载负载电流。
- c2 : 短路电流感测 (SC 触发)。
- c3 : IGBT 栅极硬中断。
- c4 : IGBT 关断。
- c5 : 故障输出延时工作启动: 故障输出信号的脉宽通过外部电容 C_{FO} 设置。
- c6 : 输入 "LOW": IGBT 关断状态。
- c7 : 输入 "HIGH": IGBT 导通, 但是在故障输出有效的时间内, IGBT 不导通。
- c8 : IGBT 关断状态。

图 8. 短路电流保护 (仅适用于低端的工作)

封装轮廓详图

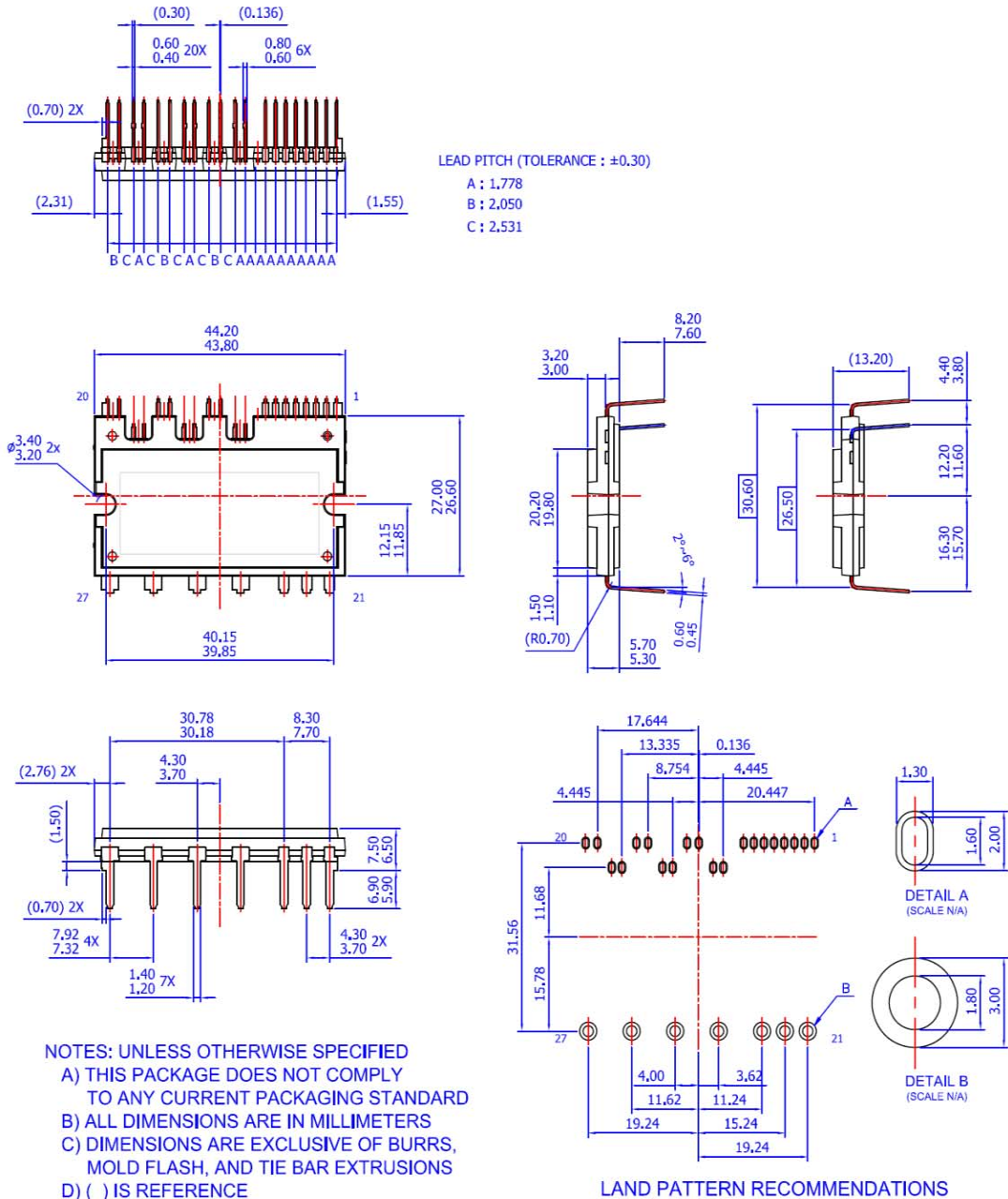

封装图纸作为一项服务，提供给考虑飞兆半导体元件的客户。具体参数可能会有变化，且不会做出相应通知。请注意图纸上的版本和 / 或日期，并联系飞兆半导体代表核实或获得最新版本。封装规格并不扩大飞兆公司全球范围内的条款与条件，尤其是其中涉及飞兆公司产品保修的部分。





随时访问飞兆半导体在线封装网页，可以获取最新的封装图纸：

<http://www.fairchildsemi.com/dwg/MO/MOD27BA.pdf>



TRADEMARKS

The following includes registered and unregistered trademarks and service marks, owned by Fairchild Semiconductor and/or its global subsidiaries, and is not intended to be an exhaustive list of all such trademarks.

AccuPower™	F-PFS™		Sync-Lock™
AX-CAP®*	FRFET®	PowerTrench®	 SYSTEM GENERAL®
BitSiC™	Global Power Resource™	PowerXS™	TinyBoost®
Build it Now™	GreenBridge™	Programmable Active Droop™	TinyBuck®
CorePLUS™	Green FPS™	QFET®	TinyCalc™
CorePOWER™	Green FPS™ e-Series™	QS™	TinyLogic®
CROSSVOLT™	Gmax™	Quiet Series™	TINYOPTO™
CTL™	GTO™	RapidConfigure™	TinyPower™
Current Transfer Logic™	IntelliMAX™		TinyPWM™
DEUXPEED®	ISOPLANAR™	Saving our world, 1mW/W/kW at a time™	TinyWire™
Dual Cool™	Making Small Speakers Sound Louder and Better™	SignalWise™	TranSiC™
EcoSPARK®	MegaBuck™	SmartMax™	TriFault Detect™
EfficientMax™	MICROCOUPLER™	SMART START™	TRUECURRENT®*
ESBC™	MicroFET™	Solutions for Your Success™	µSerDes™
	MicroPak™	SPM®	 SerDes®
Fairchild®	MicroPak2™	STEALTH™	UHC®
Fairchild Semiconductor®	MillerDrive™	SuperFET®	Ultra FRFET™
FACT Quiet Series™	MotionMax™	SuperSOT™-3	UniFET™
FACT®	mWSaver®	SuperSOT™-6	VCX™
FAST®	OptoHiT™	SuperSOT™-8	VisualMax™
FastvCore™	OPTOLOGIC®	SupreMOS®	VoltagePlus™
FETBench™	OPTOPLANAR®	SyncFET™	XS™
FPS™			

* Trademarks of System General Corporation, used under license by Fairchild Semiconductor.

DISCLAIMER

FAIRCHILD SEMICONDUCTOR RESERVES THE RIGHT TO MAKE CHANGES WITHOUT FURTHER NOTICE TO ANY PRODUCTS HEREIN TO IMPROVE RELIABILITY, FUNCTION, OR DESIGN. FAIRCHILD DOES NOT ASSUME ANY LIABILITY ARISING OUT OF THE APPLICATION OR USE OF ANY PRODUCT OR CIRCUIT DESCRIBED HEREIN; NEITHER DOES IT CONVEY ANY LICENSE UNDER ITS PATENT RIGHTS, NOR THE RIGHTS OF OTHERS. THESE SPECIFICATIONS DO NOT EXPAND THE TERMS OF FAIRCHILD'S WORLDWIDE TERMS AND CONDITIONS, SPECIFICALLY THE WARRANTY THEREIN, WHICH COVERS THESE PRODUCTS.

LIFE SUPPORT POLICY

FAIRCHILD'S PRODUCTS ARE NOT AUTHORIZED FOR USE AS CRITICAL COMPONENTS IN LIFE SUPPORT DEVICES OR SYSTEMS WITHOUT THE EXPRESS WRITTEN APPROVAL OF FAIRCHILD SEMICONDUCTOR CORPORATION.

As used herein:

1. Life support devices or systems are devices or systems which, (a) are intended for surgical implant into the body or (b) support or sustain life, and (c) whose failure to perform when properly used in accordance with instructions for use provided in the labeling, can be reasonably expected to result in a significant injury of the user.
2. A critical component in any component of a life support, device, or system whose failure to perform can be reasonably expected to cause the failure of the life support device or system, or to affect its safety or effectiveness.

ANTI-COUNTERFEITING POLICY

Fairchild Semiconductor Corporation's Anti-Counterfeiting Policy. Fairchild's Anti-Counterfeiting Policy is also stated on our external website, www.fairchildsemi.com, under Sales Support.

Counterfeiting of semiconductor parts is a growing problem in the industry. All manufacturers of semiconductor products are experiencing counterfeiting of their parts. Customers who inadvertently purchase counterfeit parts experience many problems such as loss of brand reputation, substandard performance, failed applications, and increased cost of production and manufacturing delays. Fairchild is taking strong measures to protect ourselves and our customers from the proliferation of counterfeit parts. Fairchild strongly encourages customers to purchase Fairchild parts either directly from Fairchild or from Authorized Fairchild Distributors who are listed by country on our web page cited above. Products customers buy either from Fairchild directly or from Authorized Fairchild Distributors are genuine parts, have full traceability, meet Fairchild's quality standards for handling and storage and provide access to Fairchild's full range of up-to-date technical and product information. Fairchild and our Authorized Distributors will stand behind all warranties and will appropriately address any warranty issues that may arise. Fairchild will not provide any warranty coverage or other assistance for parts bought from Unauthorized Sources. Fairchild is committed to combat this global problem and encourage our customers to do their part in stopping this practice by buying direct or from authorized distributors.

PRODUCT STATUS DEFINITIONS

Definition of Terms

Datasheet Identification	Product Status	Definition
Advance Information	Formative / In Design	Datasheet contains the design specifications for product development. Specifications may change in any manner without notice.
Preliminary	First Production	Datasheet contains preliminary data; supplementary data will be published at a later date. Fairchild Semiconductor reserves the right to make changes at any time without notice to improve design.
No Identification Needed	Full Production	Datasheet contains final specifications. Fairchild Semiconductor reserves the right to make changes at any time without notice to improve the design.
Obsolete	Not In Production	Datasheet contains specifications on a product that is discontinued by Fairchild Semiconductor. The datasheet is for reference information only.

Rev. 166

ON Semiconductor and  are trademarks of Semiconductor Components Industries, LLC dba ON Semiconductor or its subsidiaries in the United States and/or other countries. ON Semiconductor owns the rights to a number of patents, trademarks, copyrights, trade secrets, and other intellectual property. A listing of ON Semiconductor's product/patent coverage may be accessed at www.onsemi.com/site/pdf/Patent-Marking.pdf. ON Semiconductor reserves the right to make changes without further notice to any products herein. ON Semiconductor makes no warranty, representation or guarantee regarding the suitability of its products for any particular purpose, nor does ON Semiconductor assume any liability arising out of the application or use of any product or circuit, and specifically disclaims any and all liability, including without limitation special, consequential or incidental damages. Buyer is responsible for its products and applications using ON Semiconductor products, including compliance with all laws, regulations and safety requirements or standards, regardless of any support or applications information provided by ON Semiconductor. "Typical" parameters which may be provided in ON Semiconductor data sheets and/or specifications can and do vary in different applications and actual performance may vary over time. All operating parameters, including "Typicals" must be validated for each customer application by customer's technical experts. ON Semiconductor does not convey any license under its patent rights nor the rights of others. ON Semiconductor products are not designed, intended, or authorized for use as a critical component in life support systems or any FDA Class 3 medical devices or medical devices with a same or similar classification in a foreign jurisdiction or any devices intended for implantation in the human body. Should Buyer purchase or use ON Semiconductor products for any such unintended or unauthorized application, Buyer shall indemnify and hold ON Semiconductor and its officers, employees, subsidiaries, affiliates, and distributors harmless against all claims, costs, damages, and expenses, and reasonable attorney fees arising out of, directly or indirectly, any claim of personal injury or death associated with such unintended or unauthorized use, even if such claim alleges that ON Semiconductor was negligent regarding the design or manufacture of the part. ON Semiconductor is an Equal Opportunity/Affirmative Action Employer. This literature is subject to all applicable copyright laws and is not for resale in any manner.

PUBLICATION ORDERING INFORMATION

LITERATURE FULFILLMENT:

Literature Distribution Center for ON Semiconductor
19521 E. 32nd Pkwy, Aurora, Colorado 80011 USA
Phone: 303-675-2175 or 800-344-3860 Toll Free USA/Canada
Fax: 303-675-2176 or 800-344-3867 Toll Free USA/Canada
Email: orderlit@onsemi.com

N. American Technical Support: 800-282-9855 Toll Free
USA/Canada
Europe, Middle East and Africa Technical Support:
Phone: 421 33 790 2910
Japan Customer Focus Center
Phone: 81-3-5817-1050

ON Semiconductor Website: www.onsemi.com
Order Literature: <http://www.onsemi.com/orderlit>
For additional information, please contact your local
Sales Representative