

4:1 High-Speed USB Multiplexer/Switch

FSUSB74

Description

The FSUSB74 is a Bi-directional, Low-Power, High-Speed USB 2.0 4:1 MUX. It is Optimized for Switching from four High-Speed (480Mbps) sources or any combination of High-Speed and full-/low-speed USB/UART sources to one USB 2.0 connector.

Applications

- MP3 Portable Media Players
- Cellular Phones, Smart Phones
- Netbooks, Mobile Internet Devices (MID)

Related Resources

- FSUSB74 Demonstration Board
- FSUSB74 Evaluation Board

Features

Switch Type	4:1
USB	USB 2.0 High-Speed Compliant USB 2.0 Full-Speed Compliant
R _{ON}	6.5 Ω
C _{ON}	7.5 pF
ESD (IEC61000-4-2)	15 kV (Air) 8 kV (Contact)
V _{CC}	2.7 to 4.4 V
I _{CCSLP}	<1 μA
I _{CCACT}	9 μA
Package	16-Lead UMLP 1.80 x 2.60 x 0.55mm, 0.40mm Pitch 16-Lead MLP 3 x 3 x 0.7mm, 0.5mm Pitch
Ordering Information	FSUSB74UMX (UMLP) FSUSB74MPX (MLP)

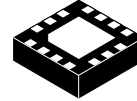

WQFN 16 3X3, 0.5P
CASE 510BS

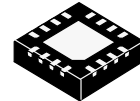

UQFN 16 1.8X2.6, 0.6P
CASE 523BF

MARKING DIAGRAM

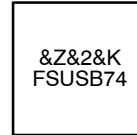

LC,FSUSB74 = Device Code
 &Z = Assembly Plant Code
 &2 = 2-Digit Date Code
 &K = 2-Digits Lot Run Lot Traceability Code
 FSUSB74 = Specific Device Code

ORDERING INFORMATION

Device	Package	Shipping [†]
FSUSB74MPX	WQFN-16 (Pb-Free)	3000 / Tape & Reel
FSUSB74UMX	UQFN-16 (Pb-Free)	3000 / Tape & Reel

[†]For information on tape and reel specifications, including part orientation and tape sizes, please refer to our Tape and Reel Packaging Specifications Brochure, [BRD8011/D](#).

FSUSB74

TYPICAL APPLICATION

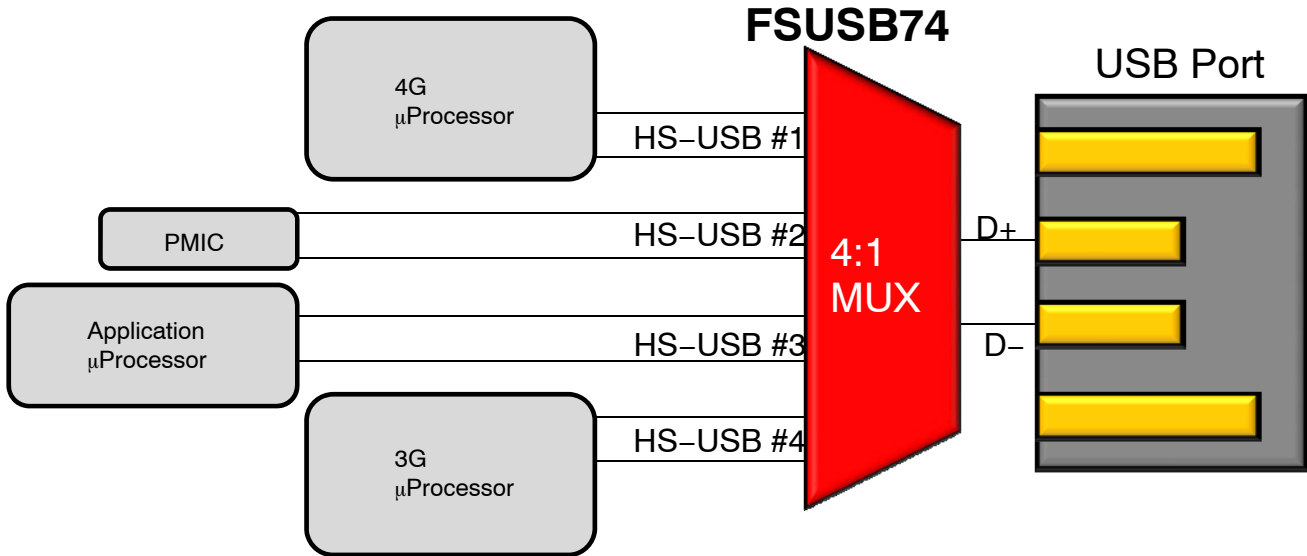

Figure 1. Mobile Phone Example

PIN CONFIGURATIONS

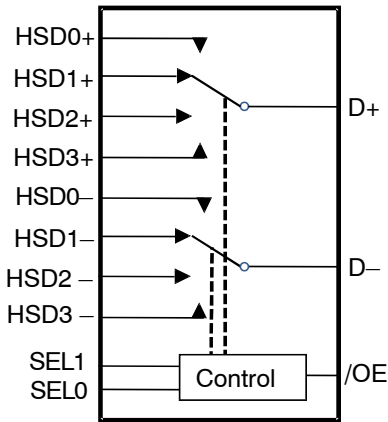

Figure 2. UMLP Analog Symbol

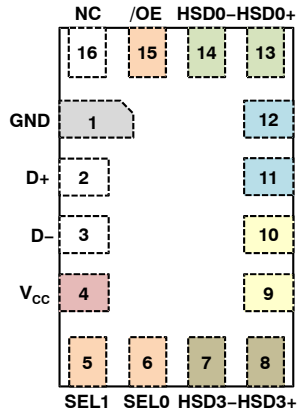

Figure 3. UMLP (Top View)

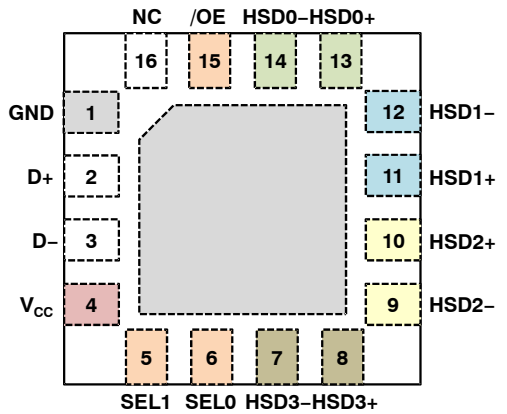

Figure 4. MLP (Top View)

FSUSB74

PIN DESCRIPTIONS

Pin No.	Name	Type	Description
1	GND	Ground	Ground
2	D+	I/O	D+ common port (HS or FS USB)
3	D-	I/O	D- common port (HS or FS USB)
4	V _{CC}	Power Supply	Supply Voltage
5	SEL1	Input	Path Selection Control Input (see truth table below)
6	SEL0	Input	Path Selection Control Input (see truth table below)
7	HSD3-	I/O	D- from fourth source path (HS or FS USB)
8	HSD3+	I/O	D+ from fourth source path (HS or FS USB)
9	HSD2-	I/O	D- from third source path (HS or FS USB)
10	HSD2+	I/O	D+ from third source path (HS or FS USB)
11	HSD1+	I/O	D+ from second source path (HS or FS USB)
12	HSD1-	I/O	D- from second source path (HS or FS USB)
13	HSD0+	I/O	D+ from first source path (HS or FS USB)
14	HSD0-	I/O	D- from first source path (HS or FS USB)
15	/OE	Input	D- from first source path (HS or FS USB)
16	NC	-	No Connect

TRUTH TABLE

/OE	SEL1	SEL0	Function
1	X	X	D+, D- Switch Paths Open
0	0	0	D+ = HSD0+, D- = HSD0-
0	0	1	D+ = HSD1+, D- = HSD1-
0	1	0	D+ = HSD2+, D- = HSD2-
0	1	1	D+ = HSD3+, D- = HSD3-

ABSOLUTE MAXIMUM RATINGS

Symbol	Parameter	Min.	Max.	Unit	
V _{CC}	Supply Voltage	-0.5	5.25	V	
V _{CNTRL}	DC Input Voltage (SEL1, SEL0, /OE, SELS) ⁽¹⁾	-0.50	V _{CC}	V	
V _{SW}	DC Switch I/O Voltage ⁽¹⁾	-0.50	5.25	V	
I _{IK}	DC Input Diode Current	-50	-	mA	
T _{STG}	Storage Temperature	-65	+150	°C	
MSL	Moisture Sensitivity Level (JEDEC J-STD-020A)	-	1	Level	
ESD	IEC61000-4-2 System on USB connector pins D+ & D-	Air Gap	15	-	kV
		Contact	8	-	
	Human Body Model, JEDEC: JESD22-A114	D+,D- to GND	6	-	
		Power to GND	12	-	
		All Other Pins	2	-	

Stresses exceeding those listed in the Maximum Ratings table may damage the device. If any of these limits are exceeded, device functionality should not be assumed, damage may occur and reliability may be affected.

1. The input and output negative ratings may be exceeded if the input and output diode current ratings are observed.

FSUSB74

RECOMMENDED OPERATING CONDITIONS

Symbol	Parameter	Min.	Max.	Unit
V_{CC}	Supply Voltage	2.5	4.4	V
V_{CNTRL} (Note 2)	Control Input Voltage (SEL1, SEL0, /OE, and SELS)	0	V_{CC}	V
V_{SW}	Switch I/O Voltage	-0.5	4.4	V
T_A	Operating Temperature	-40	+85	°C

Functional operation above the stresses listed in the Recommended Operating Ranges is not implied. Extended exposure to stresses beyond the Recommended Operating Ranges limits may affect device reliability.

2. The control input must be held HIGH or LOW; it must not float.

DC ELECTRICAL CHARACTERISTICS (All typical values are for $V_{CC} = 3.3$ V at 25°C unless otherwise specified.)

Symbol	Parameter	Test Conditions	V_{CC} (V)	$T_A = -40^\circ\text{C to } 85^\circ\text{C}$			Unit
				Min.	Typ.	Max.	
R_{ON} (Note 3)	HS Switch On Resistance	$V_{SW} = 0.4$ V, $I_{ON} = -8$ mA, Figure 5	3.3		6.5	9.0	Ω
ΔR_{ON} (Note 3)	HS Delta Ron (Note 4)	$V_{SW} = 0.4$ V, $I_{ON} = -8$ mA	3.3		0.5	0.5	Ω
I_{IN}	Control Input Leakage	All Combinations of /OE, SEL1 & SEL0 in the Truth Table ($1 = V_{CC}$, $0 = 0$ V)	4.4	-1	-	-	μA
I_{OZ}	Off State Leakage	$0 \leq D_n$, HSD0n, HSD1n, HSD2n, HSD3n ≤ 4.4 V	4.4	-1	-	-	μA
I_{OFF}	Power-Off Leakage Current (All I/O Ports)	$V_{SW} = 0$ V to 4.4 V, $V_{CC} = 0$ V, Figure 6	0	-1	-	-	μA
I_{CCSLP}	Sleep Mode Supply Current	/OE = V_{CC}	4.4	-	-	-	μA
I_{CCACT}	Active Mode Supply Current	All Active Modes in Truth Table	4.4	-	9	18	μA
I_{CCT}	Increase in I_{CC} Current per Control Input and V_{CC}	$V_{CNTRL} = 1.8$ V	4.4	-	3.3	4.0	μA
		$V_{CNTRL} = 1.2$ V	4.4	-	4.9	6.0	μA
V_{IK}	Clamp Diode Voltage	$I_{IN} = -18$ mA	2.5	-	-	-1.2	V
V_{IH}	Control Input Voltage High	SEL1, SEL0, /OE	2.5 to 4.4	1.0	-	-	V
V_{IL}	Control Input Voltage Low	SEL1, SEL0, /OE	2.5 to 4.4	-	-	0.35	V

3. Measured by the voltage drop between HSDn and Dn pins at the indicated current through the switch. On resistance is determined by the lower of the voltage on the two (HSDn or Dn ports).

4. Guaranteed by characterization.

AC ELECTRICAL CHARACTERISTICS (All typical values are for $V_{CC} = 3.3$ V at $T_A = 25^\circ\text{C}$ unless otherwise specified.)

Symbol	Parameter	Test Conditions	V_{CC} (V)	$T_A = -40^\circ\text{C to } 85^\circ\text{C}$			Unit
				Min.	Typ.	Max.	
t_{ON}	Turn-On Time when Switching from One USB Path (or Disabled i.e. /OE=1) to Another USB Path	$R_L = 50$ Ω , $C_L = 35$ pF, $V_{SW} = 0.8$ V, Figure 7, Figure 8	2.5 to 4.4	126	-	400	μs
t_{OFF}	Turn-Off Time, Turning Off Any of the USB Paths	$R_L = 50$ Ω , $C_L = 35$ pF, $V_{SW} = 0.8$ V, Figure 7, Figure 8	2.5 to 4.4	-	-	80	ns
t_{PD}	Propagation Delay (Note 5)	$C_L = 5$ pF, $R_L = 50$ Ω , Figure 7, Figure 9	3.3	-	0.25	-	ns
t_{RF}	Slow Turn-On/Off Switch Paths (Note 5)	$C_L = 5$ pF, Dn at 0 V or 3.6 V, 40.5 Ω in series with switch 10% to 90%	3.3	-	4.5	-	ns
t_{BBM}	Break-Before-Make Time (Note 5)	$R_L = 50$ Ω , $C_L = 35$ pF, $V_{SW1} = V_{SW2} = 0.8$ V, Figure 11	2.5 to 4.4	126	-	400	μs
O_{IRR}	Off Isolation (Note 5)	$R_L = 50$ Ω , $f = 240$ MHz, Figure 13	2.5 to 4.4	-	-40	-	dB
X_{talk}	Channel-to-Channel Crosstalk (Note 5)	$R_L = 50$ Ω , $f = 240$ MHz, Figure 14	2.5 to 4.4	-	-40	-	dB
$t_{SK(P)}$	Pulse Skew (Note 5)	$V_{SW} = 0.2$ V diff _{PP} , Figure 10, $C_L = 5$ pF	2.5 to 4.4	-	25	-	ps
$t_{SK(I)}$	Skew Between Differential Signals Within a Pair (Note 5)	$V_{SW} = 0.2$ V diff _{PP} , Figure 10, $C_L = 5$ pF	2.5 to 4.4	-	25	-	ps

5. Guaranteed by characterization.

FSUSB74

CAPACITANCE CHARACTERISTICS (All typical values are for $V_{CC} = 3.3\text{ V}$ at $T_A = 25^\circ\text{C}$ unless otherwise specified.)

Symbol	Parameter	Test Conditions	V_{CC} (V)	Typical	Unit
C_{IN}	Input Capacitance (Note 6)		0	3	pF
C_{ON}	D+/D- On Capacitance (Note 6)	Any Switch Path Enabled, $f = 1\text{MHz}$, Figure 16	3.3	7.5	
C_{OFF}	HSD0n, HSD1n, HSD2n, HSD3n Off Capacitance (Note 6)	If $V_{CC} = 3.3\text{ V}$, then $/OE = 3.3\text{ V}$; $f = 1\text{MHz}$, Figure 15	0 or 3.3	2.2	

6. Guaranteed by characterization.

TEST DIAGRAMS

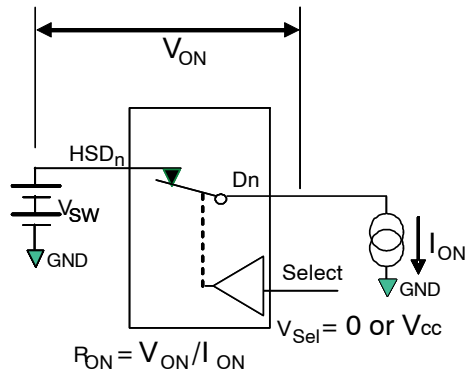
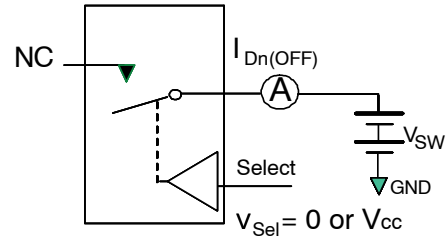

Figure 5. On Resistance



**Each switch port is tested separately

Figure 6. Off Leakage

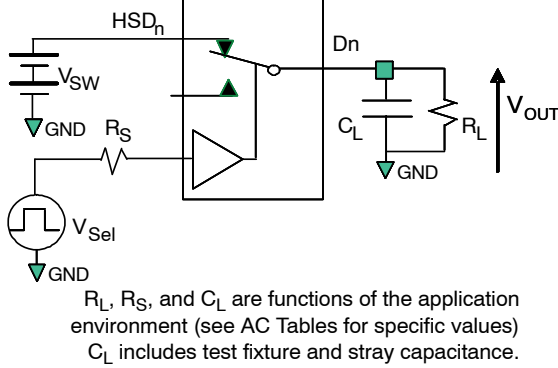

Figure 7. AC Test Circuit Load

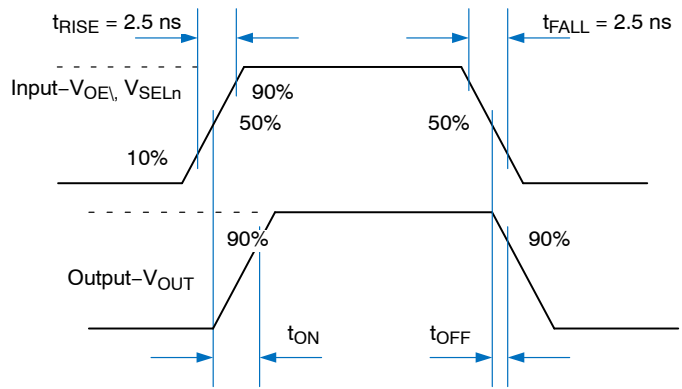

Figure 8. Turn-On / Turn-Off Waveforms

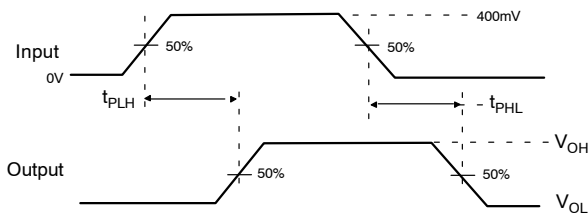

Figure 9. Propagation Delay (t_R t_F = 500 ps)

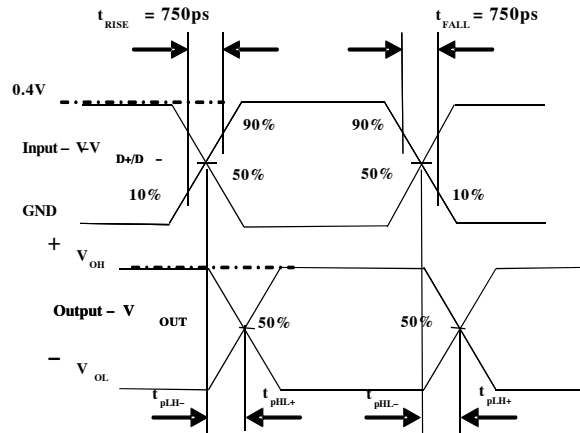
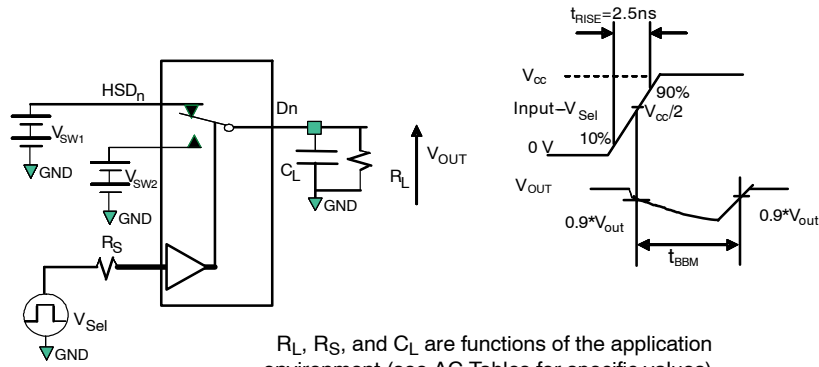

Figure 10. Skew Test Waveforms

$$t_{SK(P)} = |t_{PLH-} - t_{PHL-}| \text{ or } |t_{PLH+} - t_{PHL+}|$$

$$t_{SK(I)} = |t_{PLH-} - t_{PHL+}| \text{ or } |t_{PLH+} - t_{PHL-}|$$

TEST DIAGRAMS



R_L , R_S , and C_L are functions of the application environment (see AC Tables for specific values)
 C_L includes test fixture and stray capacitance.

Figure 11. Break-Before-Make Interval Timing

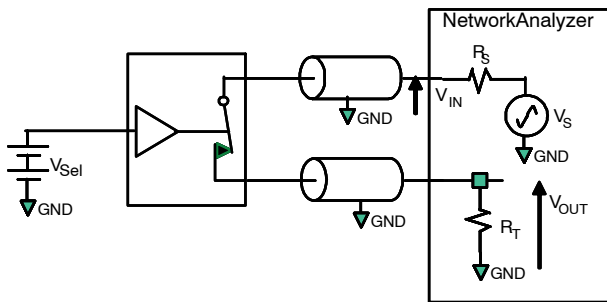

R_S , R_T , and are functions of the application environment (see AC Tables for specific values)

Figure 12. Bandwidth

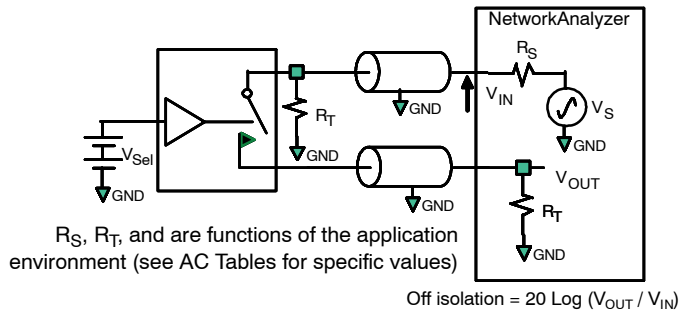

Figure 13. Channel Off Isolation

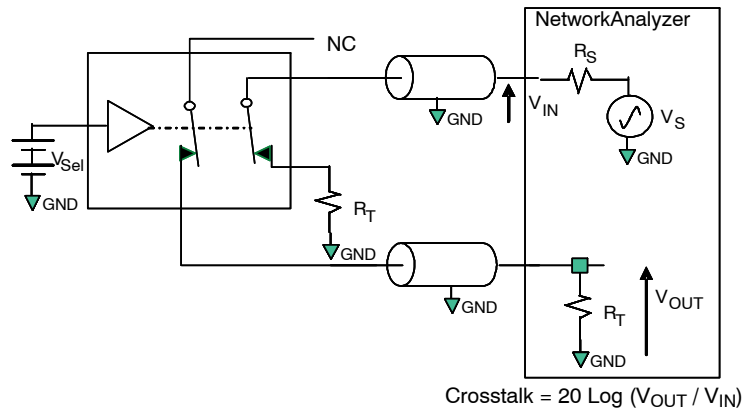

Figure 14. Non-Adjacent Channel-to-Channel Crosstalk

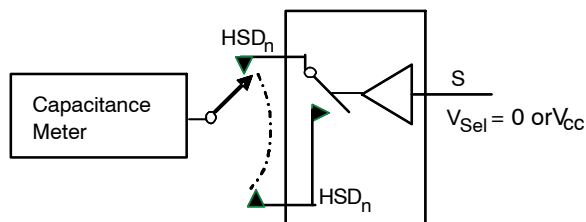

Figure 15. Channel Off Capacitance

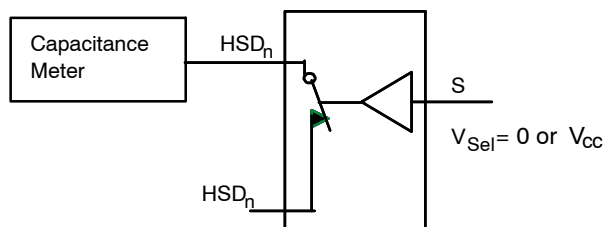

Figure 16. Channel On Capacitance

MECHANICAL CASE OUTLINE

PACKAGE DIMENSIONS

ON Semiconductor®



WQFN16 3x3, 0.5P
CASE 510BS
ISSUE O

DATE 31 AUG 2016

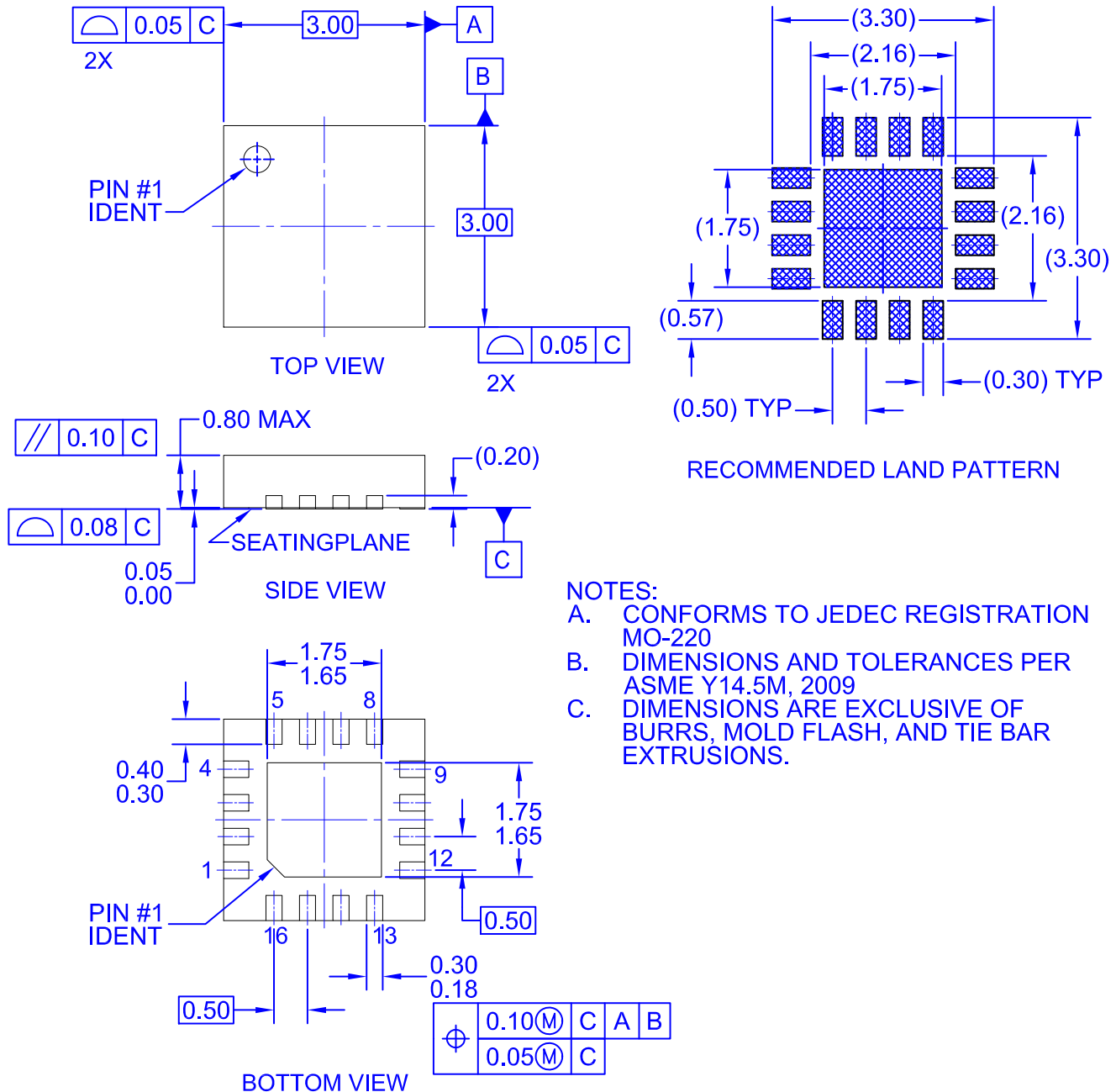

DOCUMENT NUMBER:	98AON13630G	Electronic versions are uncontrolled except when accessed directly from the Document Repository. Printed versions are uncontrolled except when stamped "CONTROLLED COPY" in red.
DESCRIPTION:	WQFN16 3X3, 0.5P	PAGE 1 OF 1

ON Semiconductor and are trademarks of Semiconductor Components Industries, LLC dba ON Semiconductor or its subsidiaries in the United States and/or other countries. ON Semiconductor reserves the right to make changes without further notice to any products herein. ON Semiconductor makes no warranty, representation or guarantee regarding the suitability of its products for any particular purpose, nor does ON Semiconductor assume any liability arising out of the application or use of any product or circuit, and specifically disclaims any and all liability, including without limitation special, consequential or incidental damages. ON Semiconductor does not convey any license under its patent rights nor the rights of others.



UQFN16 1.8x2.6, 0.4P
CASE 523BF
ISSUE O

DATE 31 OCT 2016

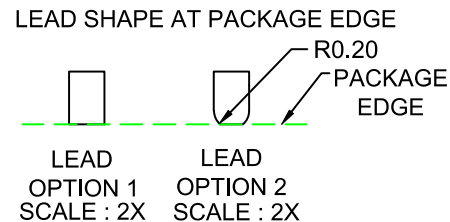
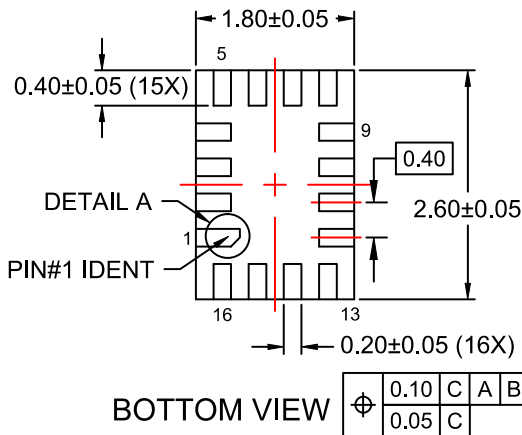
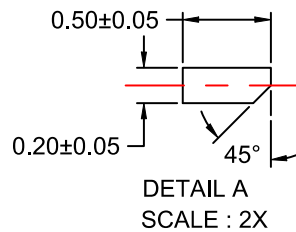
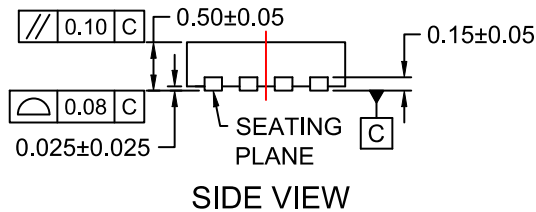
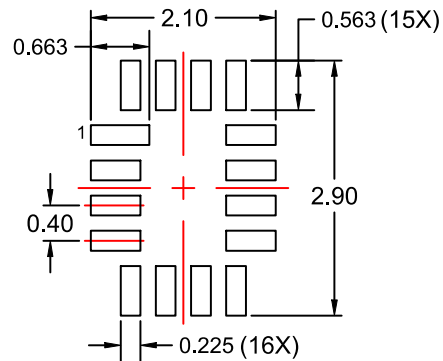
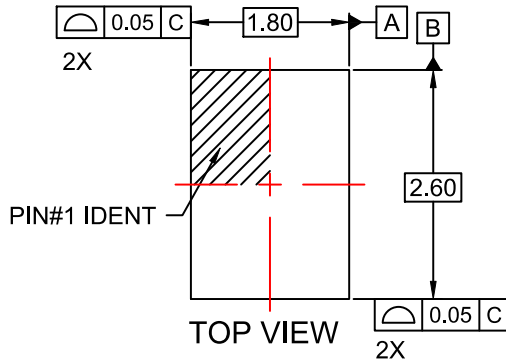

NOTES:

- A. PACKAGE DOES NOT FULLY CONFORM TO JEDEC STANDARD.
- B. DIMENSIONS ARE IN MILLIMETERS.
- C. DIMENSIONS AND TOLERANCES PER ASME Y14.5M, 2009.
- D. LAND PATTERN RECOMMENDATION IS EXISTING INDUSTRY LAND PATTERN.
- E. TERMINAL SHAPE MAY VARY ACCORDING TO PACKAGE SUPPLIER, SEE TERMINAL SHAPE VARIANTS.

DOCUMENT NUMBER:	98AON13709G	Electronic versions are uncontrolled except when accessed directly from the Document Repository. Printed versions are uncontrolled except when stamped "CONTROLLED COPY" in red.
DESCRIPTION:	UQFN16 1.8x2.6, 0.4P	PAGE 1 OF 1

ON Semiconductor and are trademarks of Semiconductor Components Industries, LLC dba ON Semiconductor or its subsidiaries in the United States and/or other countries. ON Semiconductor reserves the right to make changes without further notice to any products herein. ON Semiconductor makes no warranty, representation or guarantee regarding the suitability of its products for any particular purpose, nor does ON Semiconductor assume any liability arising out of the application or use of any product or circuit, and specifically disclaims any and all liability, including without limitation special, consequential or incidental damages. ON Semiconductor does not convey any license under its patent rights nor the rights of others.

onsemi, **Onsemi**, and other names, marks, and brands are registered and/or common law trademarks of Semiconductor Components Industries, LLC dba "**onsemi**" or its affiliates and/or subsidiaries in the United States and/or other countries. **onsemi** owns the rights to a number of patents, trademarks, copyrights, trade secrets, and other intellectual property. A listing of **onsemi**'s product/patent coverage may be accessed at www.onsemi.com/site/pdf/Patent-Marking.pdf. **onsemi** reserves the right to make changes at any time to any products or information herein, without notice. The information herein is provided "as-is" and **onsemi** makes no warranty, representation or guarantee regarding the accuracy of the information, product features, availability, functionality, or suitability of its products for any particular purpose, nor does **onsemi** assume any liability arising out of the application or use of any product or circuit, and specifically disclaims any and all liability, including without limitation special, consequential or incidental damages. Buyer is responsible for its products and applications using **onsemi** products, including compliance with all laws, regulations and safety requirements or standards, regardless of any support or applications information provided by **onsemi**. "Typical" parameters which may be provided in **onsemi** data sheets and/or specifications can and do vary in different applications and actual performance may vary over time. All operating parameters, including "Typicals" must be validated for each customer application by customer's technical experts. **onsemi** does not convey any license under any of its intellectual property rights nor the rights of others. **onsemi** products are not designed, intended, or authorized for use as a critical component in life support systems or any FDA Class 3 medical devices or medical devices with a same or similar classification in a foreign jurisdiction or any devices intended for implantation in the human body. Should Buyer purchase or use **onsemi** products for any such unintended or unauthorized application, Buyer shall indemnify and hold **onsemi** and its officers, employees, subsidiaries, affiliates, and distributors harmless against all claims, costs, damages, and expenses, and reasonable attorney fees arising out of, directly or indirectly, any claim of personal injury or death associated with such unintended or unauthorized use, even if such claim alleges that **onsemi** was negligent regarding the design or manufacture of the part. **onsemi** is an Equal Opportunity/Affirmative Action Employer. This literature is subject to all applicable copyright laws and is not for resale in any manner.

ADDITIONAL INFORMATION

TECHNICAL PUBLICATIONS:

Technical Library: www.onsemi.com/design/resources/technical-documentation
onsemi Website: www.onsemi.com

ONLINE SUPPORT: www.onsemi.com/support

For additional information, please contact your local Sales Representative at www.onsemi.com/support/sales