

# Ideal Diode NMOS Controller

## NCV68061



TSOP-6  
CASE 318G

The NCV68061 is a Reverse Polarity Protection and Ideal Diode NMOS Controller, intended as a lower loss and lower forward voltage replacement for power rectifier diodes. The controller operates in conjunction with an N-channel MOSFET for low power loss.

The main function of the NCV68061 is to control the ON/OFF state of the external NMOS according to the Source to Drain differential voltage polarity.

Depending on the Drain pin connection, the device can be configured as two different application modes. With the Drain pin connected to the load, the application is in Ideal Diode mode, whereas with the Drain pin connected to ground, the application is merely in Reverse Polarity Protection mode.

### Features

- Operating Voltage Range: up to 32 V
- Immune to 60 V Load Dump Pulse
- Immune to -40 V Negative Transient
- Ideal Diode Function
  - ♦ Protecting against Reverse Current Flow (from Output to Input)
- Reverse Polarity Protection (RPP) Function
  - ♦ Protecting against Negative Supply
- Enable Function (3.3 V Logic Compatible Thresholds)
- NCV Prefix for Automotive and Other Applications Requiring Unique Site and Control Change Requirements; AEC-Q100 Grade 1 Qualified and PPAP Capable
- These Devices are Pb-Free and are RoHS Compliant

### Typical Applications

- Automotive Battery Regulation
- Industrial Power Supply
- Power Supply OR-ing Application
- Rectifier

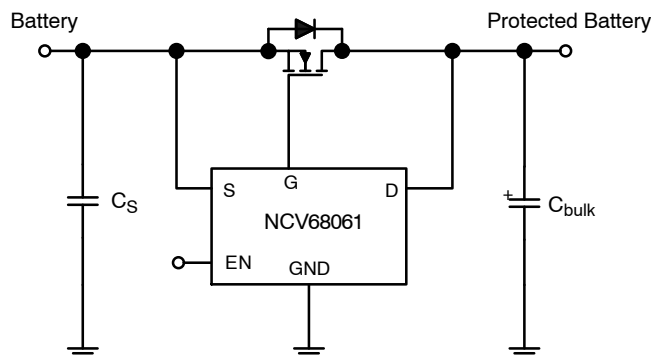
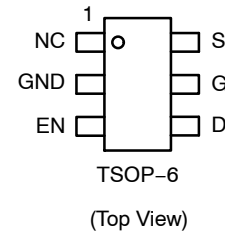
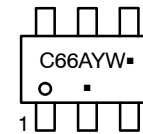

Figure 1. NCV68061 Application Schematic (Ideal Diode)

### PIN ASSIGNMENT



### MARKING DIAGRAM



C66 = Specific Device Code  
A = Assembly Location  
Y = Year  
W = Work Week  
▪ = Pb-Free Package

(Note: Microdot may be in either location)

### ORDERING INFORMATION

See detailed ordering and shipping information on page 12 of this data sheet.

# NCV68061

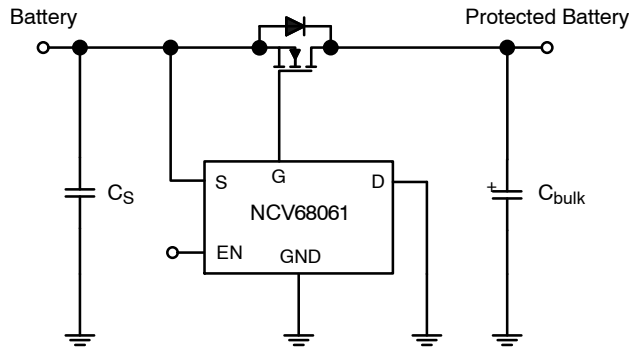

Figure 2. NCV68061 Application Schematic (Reverse Polarity Protection)

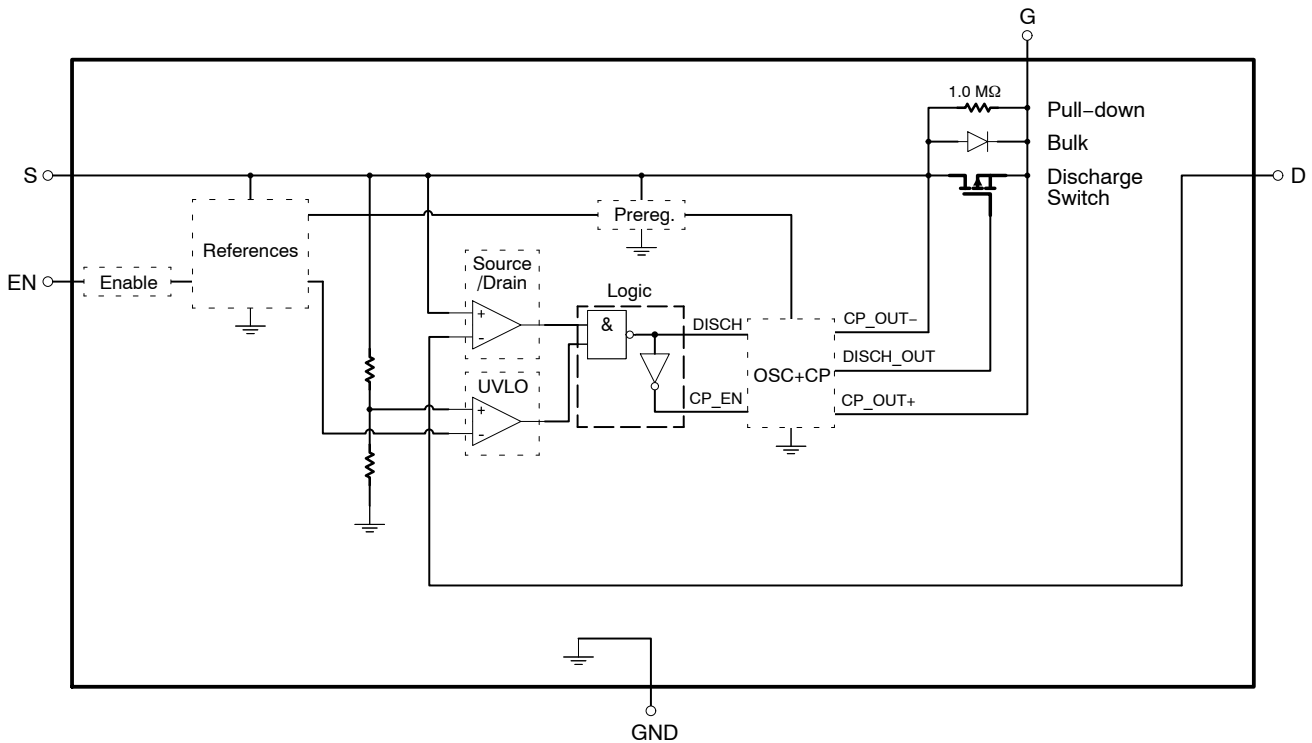

Figure 3. NCV68061 Block Diagram

Table 1. PIN FUNCTION DESCRIPTION

Pin No. TSOP-6	Pin Name	Description
1	NC	Not Connected. Not internally bonded. This pin can be left floating or connected to GND on the PCB.
2	GND	Ground potential.
3	EN	Enable Input. High Level enables the chip. Connect to Source pin if enable function is not required.
4	D	Cathode of the diode and Inverting input of the internal comparator. Bypass directly to GND with a ceramic capacitor. Connect to the Drain of the external NMOS or to the GND (see the application schematics).
5	G	Charge pump output with discharge function. Connect to the Gate of the external NMOS.
6	S	Anode of the diode, Input supply voltage pin and Non-inverting input of the internal comparator. Bypass directly to GND with a ceramic capacitor. Connect to the Source of the external NMOS.

**Table 2. MAXIMUM RATINGS**

Rating	Symbol	Min	Max	Unit
Source Voltage DC (Note 1)	$V_S$	-18	45	V
Source, Drain, Gate and Enable Voltage (Note 2) Load Dump – Suppressed	$U_{s*}$	-	60	V
Source, Gate and Enable Voltage (Note 3) Test Pulse 1	$U_s$	-40	-	V
Gate Voltage	$V_G$	-18	45	V
Gate to Source Voltage	$V_{GS}$	-0.3	19	V
Drain Voltage	$V_D$	-5	45	V
Source to Drain Voltage DC	$V_{SD}$	-45	45	
Source to Drain Voltage transient (Test Pulse 1)	$V_{SD}$	-60	-	
Enable Voltage	$V_{EN}$	-18	45	V
Operating Junction Temperature	$T_J$	-40	150	°C
Storage Temperature	$T_{STG}$	-55	150	°C

Stresses exceeding those listed in the Maximum Ratings table may damage the device. If any of these limits are exceeded, device functionality should not be assumed, damage may occur and reliability may be affected.

1. Refer to ELECTRICAL CHARACTERISTICS and APPLICATION INFORMATION for Safe Operating Area.
2. Load Dump Test B (with centralized load dump suppression) according to ISO 16750-2 standard. Guaranteed by design. Not tested in production. Passed Class A according to ISO 16750-1.
3. Test Pulse 1 according to ISO 7637-2 standard. Guaranteed by design. Not tested in production. Passed Class A according to ISO 16750-1. More ISO 7637-2: 2011(E) PULSE TEST RESULTS are in Table 8.

**Table 3. ESD CAPABILITY** (Note 4)

Rating	Symbol	Min	Max	Unit
ESD Capability, Human Body Model	$ESD_{HBM}$	-2	2	kV
ESD Capability, Charged Device Model	$ESD_{CDM}$	-1	1	kV

4. This device series incorporates ESD protection and is tested by the following methods:  
ESD Human Body Model tested per AEC-Q100-002 (JS-001-2017)  
Field Induced Charge Device Model ESD characterization is not performed on plastic molded packages with body sizes smaller than 2 x 2 mm due to the inability of a small package body to acquire and retain enough charge to meet the minimum CDM discharge current waveform characteristic defined in JEDEC JS-002-2018.

**Table 4. LEAD SOLDERING TEMPERATURE AND MSL** (Note 5)

Rating	Symbol	Min	Max	Unit
Moisture Sensitivity Level	MSL		1	-

5. For more information, please refer to our Soldering and Mounting Techniques Reference Manual, [SOLDDERM/D](#).

**Table 5. THERMAL CHARACTERISTICS** (Note 6)

Rating	Symbol	Value	Unit
Thermal Characteristics, TSOP-6 Thermal Resistance, Junction-to-Ambient Thermal Reference, Junction-to-Case Top	$R_{\theta JA}$ $\Psi_{\theta JT}$	199.1 57.3	°C/W

6. Mounted onto a 80 x 80 x 1.6 mm single layer FR4 board (645 sq mm, 1 oz. Cu, steady state).

**Table 6. RECOMMENDED OPERATING RANGES**

Rating	Symbol	Min	Max	Unit
Source Voltage	$V_S$	3	32	V
Junction Temperature	$T_J$	-40	150	°C

Functional operation above the stresses listed in the Recommended Operating Ranges is not implied. Extended exposure to stresses beyond the Recommended Operating Ranges limits may affect device reliability.

# NCV68061

**Table 7. ELECTRICAL CHARACTERISTICS**

( $V_S = 13.5\text{ V}$ ,  $V_{EN} = 5\text{ V}$ ,  $C_S = 0.1\text{ }\mu\text{F}$ ,  $C_{bulk} = 1\text{ }\mu\text{F}$ , Min and Max values are valid for temperature range  $-40^\circ\text{C} \leq T_J \leq +150^\circ\text{C}$  unless noted otherwise and are guaranteed by test, design or statistical correlation. Typical values are referenced to  $T_J = 25^\circ\text{C}$ )

Parameter	Test Conditions	Symbol	Min	Typ	Max	Unit
<b>CHARGE PUMP OPERATION</b>						
Undervoltage Lockout	$V_S$ rising $V_S$ falling (Gate Discharge)	$V_{S\_UVLO}$	- 3	3.3 3.2	3.5 -	V
Gate to Source Charged Voltage	$V_S = 4\text{ V}$ $V_S \geq 8\text{ V}$	$V_{GS}$	3 9	4.0 11.4	- 15	V
Source to Drain Voltage Threshold Gate Charge Gate Discharge	$V_{SD}$ rising $V_{SD}$ falling	$V_{th(SD)}$	100 -40	140 -10	220 0	mV
Gate Charge Current	$V_{GS} = 0\text{ V}$ , $V_{SD} = 220\text{ mV}$ $V_S = 4\text{ V}$ $V_S = 13.5\text{ V}$	$I_{G\_Charge}$	70 170	105 325	- -	$\mu\text{A}$
Gate Discharge Peak Current	$V_{GS} = 10\text{ V}$ , $V_{SD} \leq -100\text{ mV}$	$I_{G\_Disch}$	-	1.85	-	A
Discharge Switch $R_{DS(on)}$	$V_{GS} = 100\text{ mV}$ , $V_{SD} \leq -100\text{ mV}$	$R_{DS(on)}$	1	2.2	5	$\Omega$
Response Time (Time from Reverse Voltage Condition to $V_{GS} = 9\text{ V}$ )	$V_{GS} = 10\text{ V}$ , $V_S = 13.5\text{ V}$ , $V_{SD} = \text{step from } 250\text{ mV to } -150\text{ mV}$	$t_{rt\_OFF}$	-	0.2	0.6	$\mu\text{s}$
Gate to Source Static Resistance			-	1.05	-	$\text{M}\Omega$

### DISABLE AND QUIESCENT CURRENTS

Disable Current	$V_{EN} = 0\text{ V}$	$I_{DIS}$	-	-	5	$\mu\text{A}$
Quiescent Current	$I_G = 0\text{ mA}$ , $V_{SD} = 220\text{ mV}$ (CP active)	$I_q$	-	215	295	$\mu\text{A}$

### ENABLE

Enable Input Threshold Voltage Logic Low Logic High	$V_{GS} \leq 0.1\text{ V}$ $V_{GS} \geq 4.9\text{ V}$	$V_{th(EN)}$	0.99 -	1.55 1.70	- 2.31	V
Enable Input Current Logic High Logic High Logic Low	$V_{EN} = 13.5\text{ V}$ $V_{EN} = 5\text{ V}$ $V_{EN} = 0\text{ V}$	$I_{EN\_ON}$ $I_{EN\_ON}$ $I_{EN\_OFF}$	- - -	12 3.5 0.010	- 5 1	$\mu\text{A}$

Product parametric performance is indicated in the Electrical Characteristics for the listed test conditions, unless otherwise noted. Product performance may not be indicated by the Electrical Characteristics if operated under different conditions.

TYPICAL CHARACTERISTICS

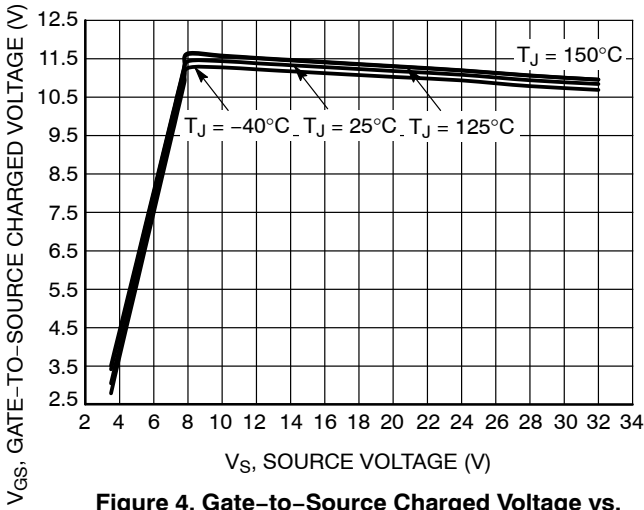

Figure 4. Gate-to-Source Charged Voltage vs. Source Voltage

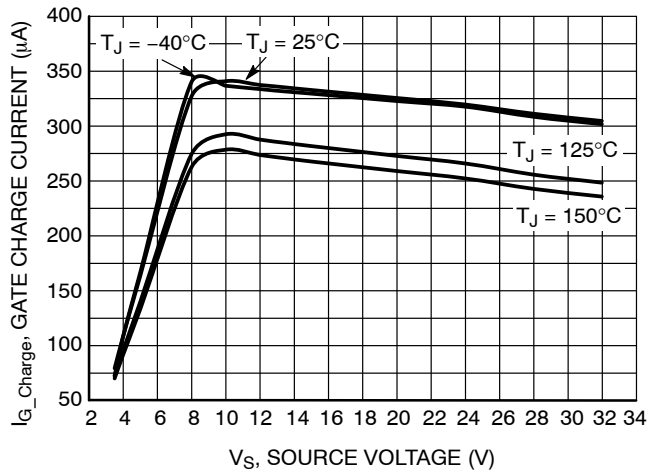

Figure 5. Gate Charge Current vs. Source Voltage

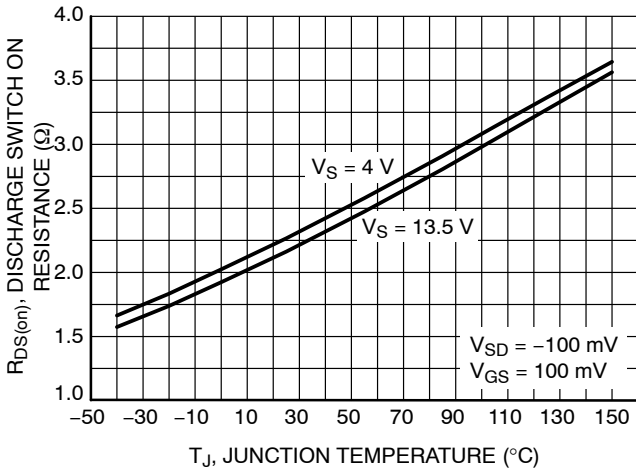

Figure 6. Discharge Switch On Resistance vs. Temperature

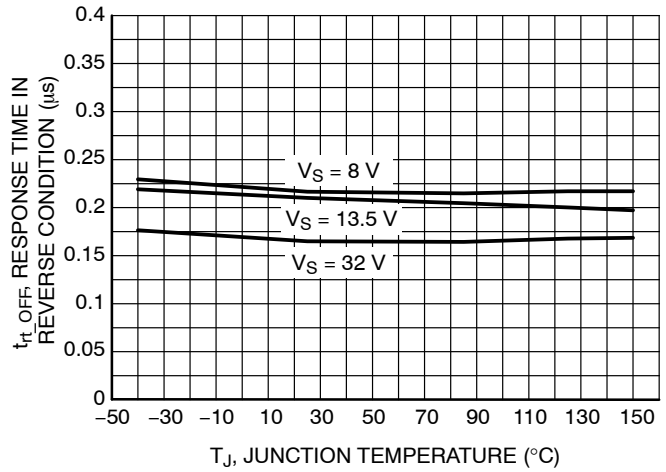

Figure 7. Charge Pump Output Response Time in Reverse Condition (from  $V_{SD} = 0$  V to  $V_{GS} = 9$  V) vs. Temperature

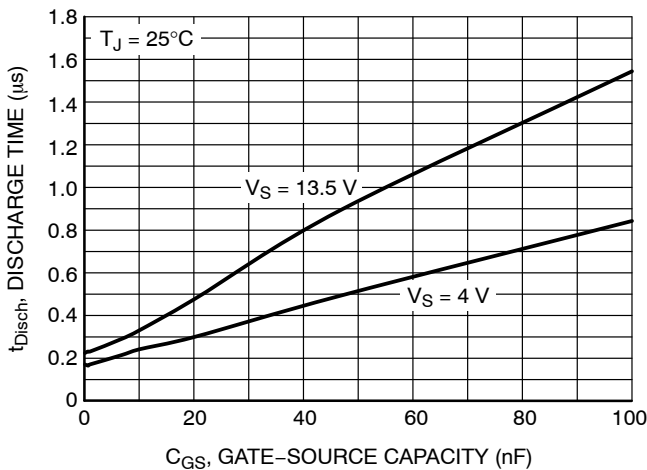

Figure 8. Discharge Time (from  $V_{SD} = 0$  V to  $V_{GS} = 0$  V) vs. Gate-Source Capacitance

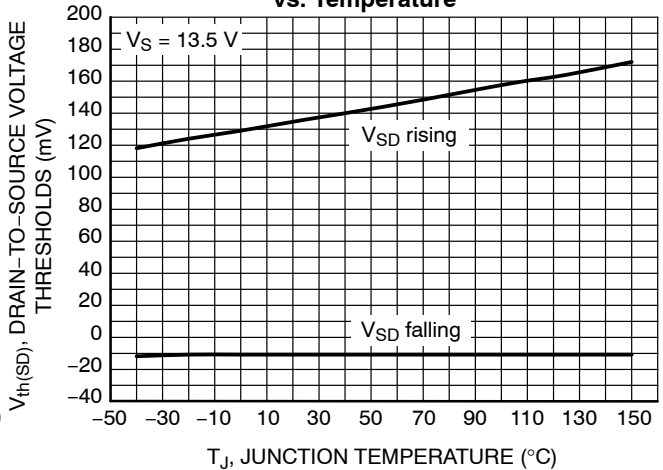

Figure 9. Drain-to-Source Voltage Thresholds vs. Temperature

TYPICAL CHARACTERISTICS

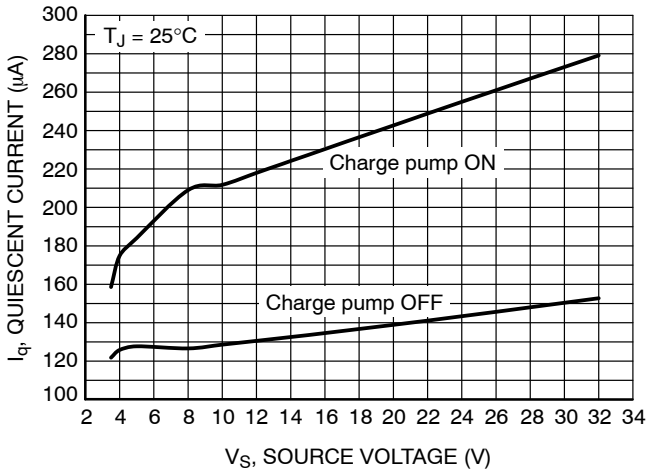

Figure 10. Quiescent Current vs. Source Voltage

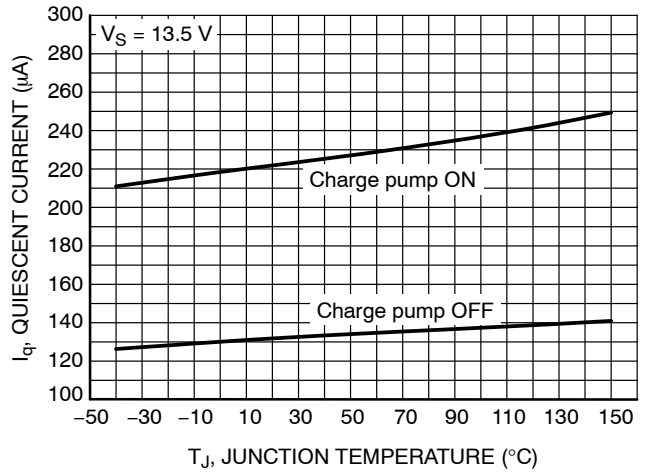

Figure 11. Quiescent Current vs. Temperature

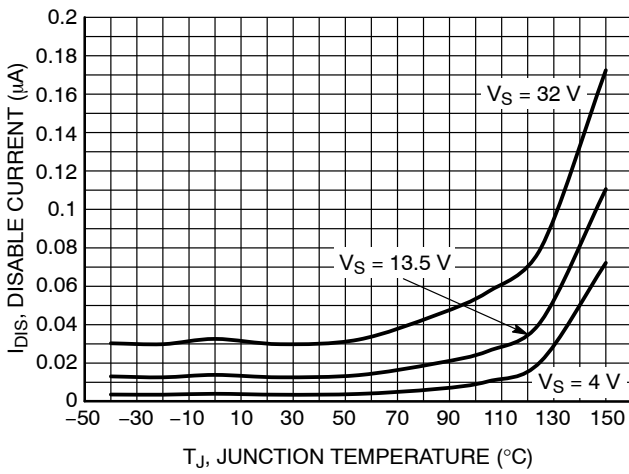

Figure 12. Disable Current vs. Temperature

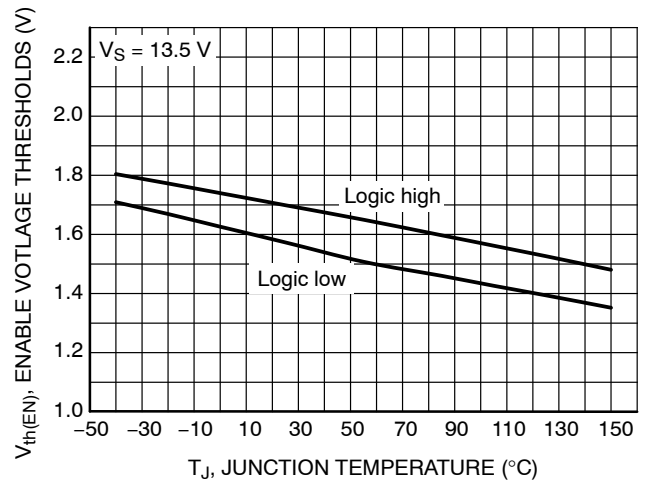

Figure 13. Enable Voltage Thresholds vs. Temperature

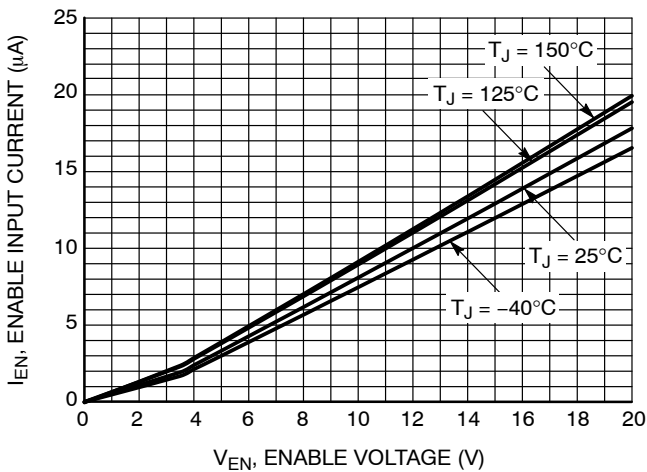

Figure 14. Enable Input Current vs. Enable Voltage

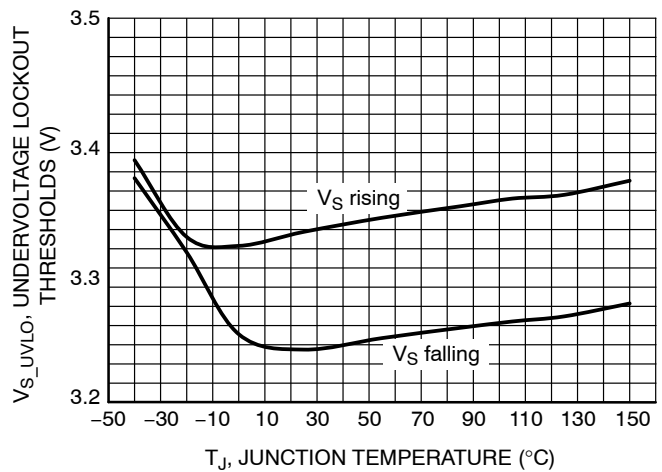

Figure 15. Undervoltage Lockout (UVLO) Thresholds vs. Temperature

TYPICAL CHARACTERISTICS

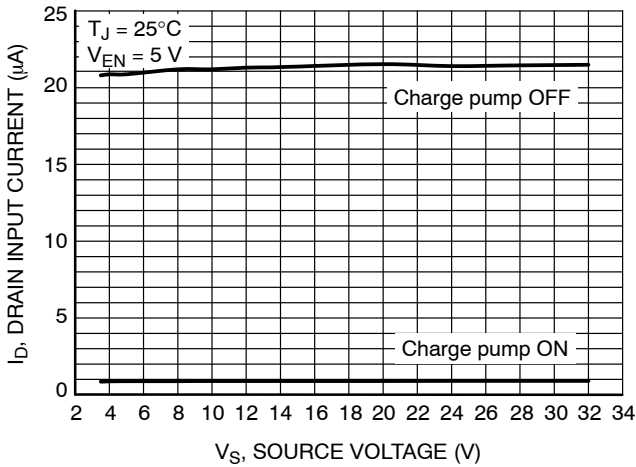

Figure 16. Drain Input Current vs. Source Voltage

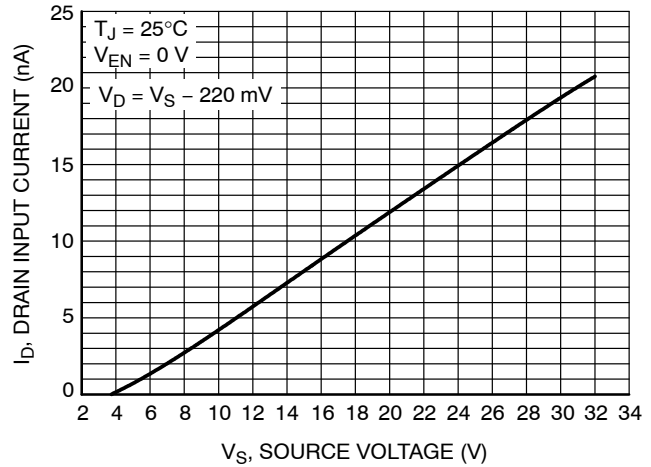

Figure 17. Drain Input Current vs. Source Voltage

Table 8. ISO 7637-2: 2011(E) PULSE TEST RESULTS

ISO 7637-2:2011(E) Test Pulse	Test Severity Levels, 12 V System			Delays and Impedance	# of Pulses or Test Time	Pulse / Burst Rep. Time
	I / II	III	IV			
1	-75	-112	-150	2 ms, 10 Ω	500 pulses	0.5 s
2a	+37	+55	+112	0.05 ms, 2 Ω	500 pulses	0.5 s
3a	-112	-165	-220	0.1 µs, 50 Ω	1 h	100 ms
3b	+75	+112	+150	0.1 µs, 50 Ω	1 h	100 ms

ISO 7637-2:2011(E)	Test Results		
Test Pulse	I / II	III	IV
1	A	E	
2a		A	E
3a	E		
3b			A

Class	Functional Status
A	All functions of a device perform as designed during and after exposure to disturbance.
B	All functions of a device perform as designed during exposure. However, one or more of them can go beyond specified tolerance. All functions return automatically to within normal limits after exposure is removed. Memory functions shall remain class A.
C	One or more functions of a device do not perform as designed during exposure but return automatically to normal operation after exposure is removed.
D	One or more functions of a device do not perform as designed during exposure and do not return to normal operation until exposure is removed and the device is reset by simple "operator/use" action.
E	One or more functions of a device do not perform as designed during and after exposure and cannot be returned to proper operation without replacing the device.

**APPLICATION INFORMATION**  
**Integrated Circuit and Block Diagram Description**

**Integrated Circuit Description**

The NCV68061 operates in conjunction with an external NMOS transistor. Two basic applications can be configured. An **Ideal diode application** or a **Reverse Polarity Protection application**. See the basic application schematics in Figures 1 and 2. The difference in configuration between the two applications is in the Drain pin connection, which is an inverting input of the Source/Drain comparator. Table 9 shows the available protection features based on the Drain pin connection.

**Enable**

The Enable block turns the controller ON and OFF. If the Enable function is not needed, then the Enable pin can be connected to the Source (input voltage) for permanent operation.

**References**

The References block provides voltage references and voltage supply for other internal circuitry. This block is supplied from the Source and controlled by the Enable block.

**Source/Drain Comparator**

This comparator compares voltage levels at the Source and Drain pins. Based on the Drain pin connection, two basic applications can be designed (Figures 1 and 2).

**UVLO Comparator**

The undervoltage lockout (UVLO) comparator compares the Source (input) voltage level with an internal reference voltage level. When the Source voltage falls below the UVLO threshold, the output of the UVLO comparator is set to low resulting in turning OFF the charge pump and switching OFF the external NMOS transistor.

**Logic**

The Logic block controls the Charge Pump block according to the inputs from the Source/Drain and UVLO comparators. The truth table of the logic function is shown in Table 10.

**Pre-regulator**

The pre-regulator provides a stable voltage supply for the charge pump block.

**Oscillator and Charge Pump**

The oscillator generates an approximately 2 MHz clock signal that drives the charge pump. The charge pump generates the Gate-Source voltage from the voltage provided by the pre-regulator. The OSC+CP block drives the discharge switch as well.

**Table 9. AVAILABLE PROTECTION FEATURES**

Drain Pin Connection	Protection Features	
	Reverse Current Protection	Reverse Polarity Protection
Load Side (Protected Battery) (see Fig. 1)	Yes	Yes
GND (see Fig. 2)	No	Yes

**Table 10. TRUTH TABLE OF THE LOGIC (@ EN = HIGH)**

Source/Drain Comparator	UVLO Comparator	DISCH	CP_EN	NMOS
$V_S < V_D$	$V_S < V_{S\_UVLO}$	TRUE	FALSE	OFF
$V_S < V_D$	$V_S > V_{S\_UVLO}$	TRUE	FALSE	OFF
$V_S > V_D$	$V_S < V_{S\_UVLO}$	TRUE	FALSE	OFF
$V_S > V_D$	$V_S > V_{S\_UVLO}$	FALSE	TRUE	ON

## APPLICATION INFORMATION

**Operation**

The main function of the NCV68061 is to control the ON/OFF state of an external NMOS transistor depending on the difference between the voltages at the NCV68061 Source and Drain pins – as shown in Figures 1 and 2. Figure 3 illustrates the internal connections between the functional blocks described above.

**OFF state:** When the Enable input is low, the IC is in disable mode. All the internal blocks are turned OFF, and the current consumption is reduced – typically down to tens of nano–amps. In this state, the external transistor is kept OFF by an integrated 1 M $\Omega$  resistor between the Gate and Source pins.

**ON state:** When the Enable input is high, the IC is active. Further operation depends on the output state of the UVLO and Source/Drain comparators. Table 10 shows the charge pump, gate discharge, and NMOS transistor states resulting from the 4 possible output states of these comparators. The charge pump is turned ON only when the Source voltage level is above both the UVLO threshold and above the Drain voltage level.

**Undervoltage Lockout:** When the Source voltage falls below the UVLO thresholds (typ. 3.2 V), the charge pump is disabled and the external NMOS transistor is turned OFF by an internal PMOS transistor. By decreasing the Source voltage further, the chip is insufficiently powered, and the external NMOS is kept in OFF state by the integrated 1 M $\Omega$  resistor (see Figure 3).

**Application Configurations****Ideal Diode**

In the Ideal Diode configuration (Figure 1), the input voltage is not allowed to discharge the output.

**Conduction Mode:** Prior to entering the conduction mode, the Source voltage is lower than the Drain voltage, and the charge pump and the NMOS transistor are disabled. As Source voltage becomes greater than Drain voltage, forward current flows through the body diode of the NMOS transistor. Once this forward voltage drop exceeds the Source to Drain Gate Charge Voltage Threshold level (typ. 140 mV), the charge pump is turned ON and the NMOS transistor becomes fully conductive.

**Reverse Current Blocking:** When the Source voltage becomes less than the Drain voltage, reverse current initially flows through the conductive channel of the NMOS transistor. This current creates a voltage drop across the conductive channel of the NMOS transistor which is proportional to its R<sub>DS(ON)</sub> resistance. When this voltage crosses below the Source to Drain Gate Discharge Voltage Threshold (typ. –10 mV), the charge pump is disabled and the external NMOS transistor is turned OFF by an internal PMOS transistor (see Figure 3).

**Reverse Polarity Protection (RPP)**

By connecting the Drain pin to the GND potential (Figure 2), the NCV68061 does not allow a falling input voltage to discharge the output below GND potential, but does allow the output to follow any positive input voltage above the UVLO threshold. When Source voltage is above the UVLO threshold (typ. 3.3 V), the Source/Drain and UVLO comparators enable the Charge Pump to provide Gate–Source voltage to the external NMOS transistor, which is fully conductive. For Source voltage below the UVLO threshold (typ. 3.2 V), the Charge Pump and the NMOS transistor are disabled, and any load current flows through the body diode of the NMOS transistor.

# NCV68061

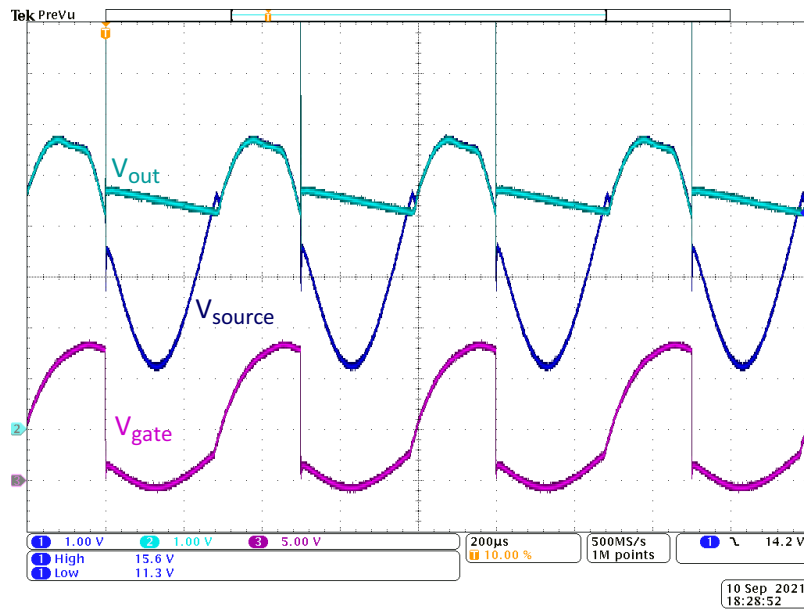

Figure 18. Application Response to 13.5 V + 5 Vpp Sine Wave on the Input ( $V_{Source}$ ) – Ideal Diode Application (see Figure 1)

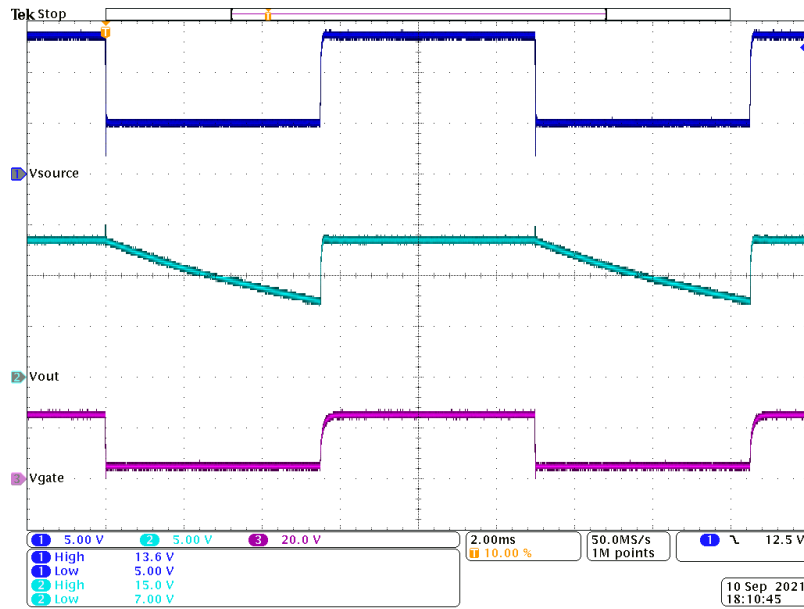

Figure 19. Application Response to Transient on the Input ( $V_{Source}$ ) from 13.5 V to 5 V – Ideal Diode Application (see Figure 1)

# NCV68061

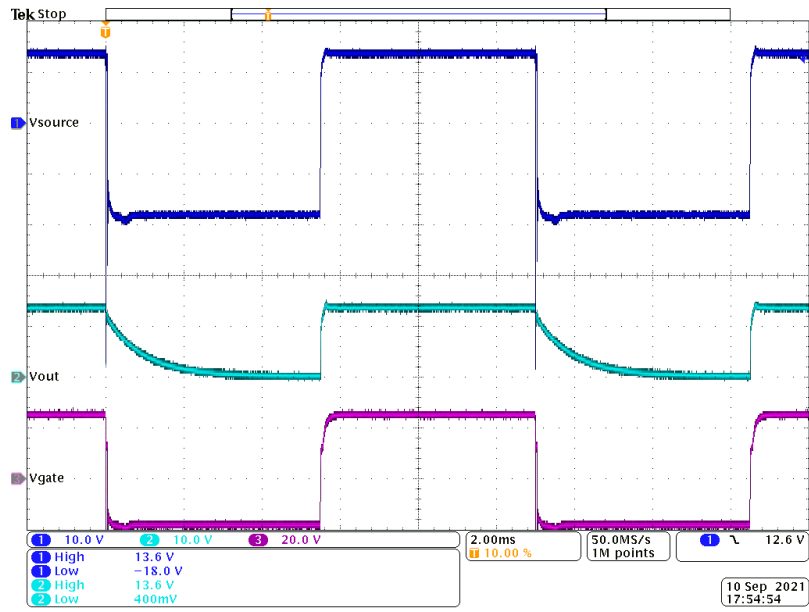

Figure 20. Application Response to Transient on the Input ( $V_{Source}$ ) from 13.5 V to -18 V – Reverse Polarity Protection Application (see Figure 2)

**C<sub>S</sub> (Input) Capacitor Considerations**

For proper device performance, it is recommended that a 0.1 μF ceramic capacitor be placed as close as possible to the NCV68061, and connected with the shortest possible traces.

**C<sub>bulk</sub> (Output) Capacitor Considerations**

Besides presenting a sufficiently low impedance for the load input rail, in an Ideal Diode application the C<sub>bulk</sub> capacitance should be high enough to maintain adequate voltage while providing load current for the duration of battery sag plus the charge from reverse current spike before the NMOS transistor turns off. Capacitor ESR is also limited by the R<sub>DS(ON)</sub> of the NMOS, as high ESR can reduce reverse current flow below that needed to create sufficient NMOS reverse voltage drop (see Figure 18). The value of the C<sub>bulk</sub> capacitor can be calculated according to the equation 1:

$$C_{bulk} = \frac{t_{Disch} \cdot \frac{\Delta U_s}{R_{DS(ON)}} + I_{load} \cdot t_{drop}}{\Delta U_{out}} \quad (eq. 1)$$

where:

- t<sub>Disch</sub> – discharge time for the given Gate–Source capacity of the external NMOS (see Figure 8)
- ΔU<sub>s</sub> – expected battery voltage drop
- R<sub>DS(ON)</sub> – ON resistance of the external NMOS transistor
- t<sub>drop</sub> – the expected duration of the battery voltage drop
- ΔU<sub>out</sub> – the maximum allowed drop of the output voltage

**NMOS Transistor Considerations**

In general, any NMOS can be connected to the NCV68061. There are no special requirements for the transistor. From the NCV68061 perspective, the Gate to Source maximum voltage of the transistor should be rated above a 15 V level (see Table 7 with electrical characteristics) unless an external voltage protection is applied to protect the Gate–Source structure from a breakdown.

**Thermal Considerations**

The NCV68061 has no thermal protection function as it is not designed to handle large currents itself. Regarding the application, the most heated element is the external NMOS transistor. In case an SMD transistor is used, maximum power dissipation, thermal resistance of the NMOS and cooling area of the PCB should be considered to keep the junction temperature of the controller below 150°C.

**PCB Layout Considerations**

For optimal EMC and dynamic performance, place the components as close as possible to the NCV68061. Tracks carrying high load current – Source (Battery), Drain (Protected Battery) and GND are recommended to connect using power planes on the PCB. A PCB Layout example is shown in Figure 21.

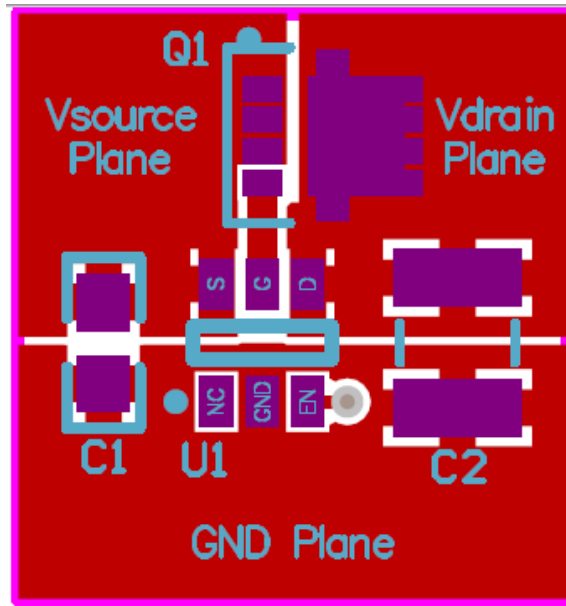
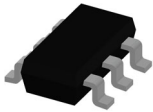

Figure 21. PCB Layout Example

**ORDERING INFORMATION**

Device	Marking	Package	Shipping†
NCV68061SNAIT1G	C66	TSOP-6 (Pb-Free)	3,000 / Tape & Reel

†For information on tape and reel specifications, including part orientation and tape sizes, please refer to our Tape and Reel Packaging Specifications Brochure, BRD8011/D.



**TSOP-6 3.00x1.50x0.90, 0.95P**  
**CASE 318G**  
**ISSUE W**

DATE 26 FEB 2024

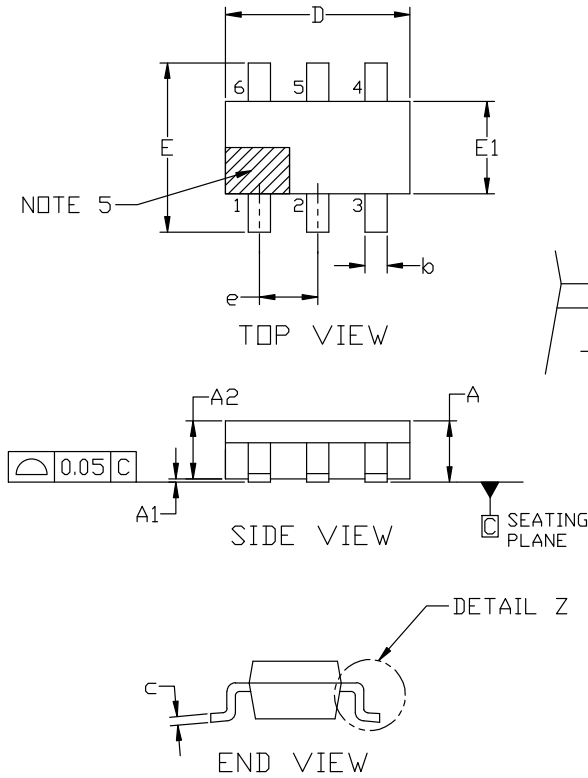

NOTES:

1. DIMENSIONING AND TOLERANCING PER ASME Y14.5M, 2018.
2. CONTROLLING DIMENSION: MILLIMETERS.
3. MAXIMUM LEAD THICKNESS INCLUDES LEAD FINISH. MINIMUM LEAD THICKNESS IS THE MINIMUM THICKNESS OF BASE MATERIAL.
4. DIMENSIONS D AND E1 DO NOT INCLUDE MOLD FLASH, PROTRUSIONS, OR GATE BURRS. MOLD FLASH, PROTRUSIONS, OR GATE BURRS SHALL NOT EXCEED 0.15 PER SIDE. DIMENSIONS D AND E1 ARE DETERMINED AT DATUM H.
5. PIN 1 INDICATOR MUST BE LOCATED IN THE INDICATED ZONE

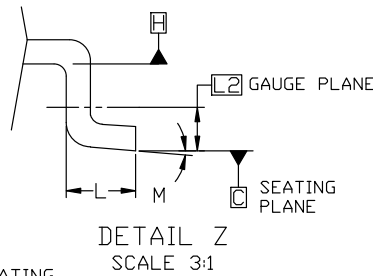

MILLIMETERS			
DIM	MIN	NOM	MAX
A	0.90	1.00	1.10
A1	0.01	0.06	0.10
A2	0.80	0.90	1.00
b	0.25	0.38	0.50
c	0.10	0.18	0.26
D	2.90	3.00	3.10
E	2.50	2.75	3.00
E1	1.30	1.50	1.70
e	0.85	0.95	1.05
L	0.20	0.40	0.60
L2	0.25 BSC		
M	0°	---	10°

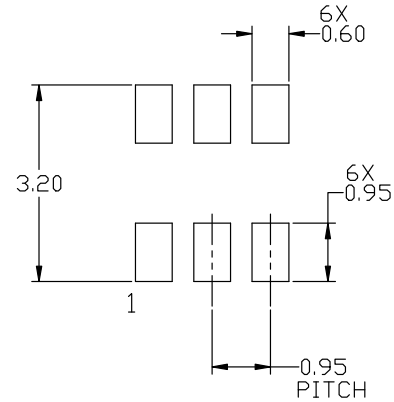

RECOMMENDED MOUNTING FOOTPRINT

\*For additional information on our Pb-Free strategy and soldering details, please download the ON Semiconductor Soldering and Mounting Techniques Reference manual, SOLDERRM/D.

<b>DOCUMENT NUMBER:</b>	<b>98ASB14888C</b>	Electronic versions are uncontrolled except when accessed directly from the Document Repository. Printed versions are uncontrolled except when stamped "CONTROLLED COPY" in red.
<b>DESCRIPTION:</b>	<b>TSOP-6 3.00x1.50x0.90, 0.95P</b>	<b>PAGE 1 OF 2</b>

onsemi and ONSEMI are trademarks of Semiconductor Components Industries, LLC dba onsemi or its subsidiaries in the United States and/or other countries. onsemi reserves the right to make changes without further notice to any products herein. onsemi makes no warranty, representation or guarantee regarding the suitability of its products for any particular purpose, nor does onsemi assume any liability arising out of the application or use of any product or circuit, and specifically disclaims any and all liability, including without limitation special, consequential or incidental damages. onsemi does not convey any license under its patent rights nor the rights of others.

**TSOP-6 3.00x1.50x0.90, 0.95P**  
**CASE 318G**  
**ISSUE W**

DATE 26 FEB 2024

**GENERIC  
MARKING DIAGRAM\***

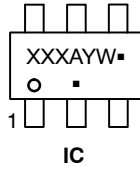

**IC**

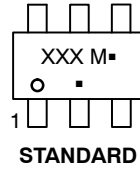

**STANDARD**

XXX = Specific Device Code	XXX = Specific Device Code
A = Assembly Location	M = Date Code
Y = Year	▪ = Pb-Free Package
W = Work Week	
▪ = Pb-Free Package	

\*This information is generic. Please refer to device data sheet for actual part marking. Pb-Free indicator, "G" or microdot "▪", may or may not be present. Some products may not follow the Generic Marking.

- |   |   |  |  |  |   |
|---|---|--|--|--|---|
| <p><b>STYLE 1:</b><br/> PIN 1. DRAIN<br/> 2. DRAIN<br/> 3. GATE<br/> 4. SOURCE<br/> 5. DRAIN<br/> 6. DRAIN</p>              | <p><b>STYLE 2:</b><br/> PIN 1. EMITTER 2<br/> 2. BASE 1<br/> 3. COLLECTOR 1<br/> 4. EMITTER 1<br/> 5. BASE 2<br/> 6. COLLECTOR 2</p>    | <p><b>STYLE 3:</b><br/> PIN 1. ENABLE<br/> 2. N/C<br/> 3. R BOOST<br/> 4. Vz<br/> 5. V in<br/> 6. V out</p>                            | <p><b>STYLE 4:</b><br/> PIN 1. N/C<br/> 2. V in<br/> 3. NOT USED<br/> 4. GROUND<br/> 5. ENABLE<br/> 6. LOAD</p>                | <p><b>STYLE 5:</b><br/> PIN 1. EMITTER 2<br/> 2. BASE 2<br/> 3. COLLECTOR 1<br/> 4. EMITTER 1<br/> 5. BASE 1<br/> 6. COLLECTOR 2</p> | <p><b>STYLE 6:</b><br/> PIN 1. COLLECTOR<br/> 2. COLLECTOR<br/> 3. BASE<br/> 4. EMITTER<br/> 5. COLLECTOR<br/> 6. COLLECTOR</p> |
| <p><b>STYLE 7:</b><br/> PIN 1. COLLECTOR<br/> 2. COLLECTOR<br/> 3. BASE<br/> 4. N/C<br/> 5. COLLECTOR<br/> 6. EMITTER</p>   | <p><b>STYLE 8:</b><br/> PIN 1. Vbus<br/> 2. D(in)<br/> 3. D(in)+<br/> 4. D(out)+<br/> 5. D(out)<br/> 6. GND</p>                         | <p><b>STYLE 9:</b><br/> PIN 1. LOW VOLTAGE GATE<br/> 2. DRAIN<br/> 3. SOURCE<br/> 4. DRAIN<br/> 5. DRAIN<br/> 6. HIGH VOLTAGE GATE</p> | <p><b>STYLE 10:</b><br/> PIN 1. D(OUT)+<br/> 2. GND<br/> 3. D(OUT)-<br/> 4. D(IN)-<br/> 5. VBUS<br/> 6. D(IN)+</p>             | <p><b>STYLE 11:</b><br/> PIN 1. SOURCE 1<br/> 2. DRAIN 2<br/> 3. DRAIN 2<br/> 4. SOURCE 2<br/> 5. GATE 1<br/> 6. DRAIN 1/GATE 2</p>  | <p><b>STYLE 12:</b><br/> PIN 1. I/O<br/> 2. GROUND<br/> 3. I/O<br/> 4. I/O<br/> 5. VCC<br/> 6. I/O</p>                          |
| <p><b>STYLE 13:</b><br/> PIN 1. GATE 1<br/> 2. SOURCE 2<br/> 3. GATE 2<br/> 4. DRAIN 2<br/> 5. SOURCE 1<br/> 6. DRAIN 1</p> | <p><b>STYLE 14:</b><br/> PIN 1. ANODE<br/> 2. SOURCE<br/> 3. GATE<br/> 4. CATHODE/DRAIN<br/> 5. CATHODE/DRAIN<br/> 6. CATHODE/DRAIN</p> | <p><b>STYLE 15:</b><br/> PIN 1. ANODE<br/> 2. SOURCE<br/> 3. GATE<br/> 4. DRAIN<br/> 5. N/C<br/> 6. CATHODE</p>                        | <p><b>STYLE 16:</b><br/> PIN 1. ANODE/CATHODE<br/> 2. BASE<br/> 3. EMITTER<br/> 4. COLLECTOR<br/> 5. ANODE<br/> 6. CATHODE</p> | <p><b>STYLE 17:</b><br/> PIN 1. EMITTER<br/> 2. BASE<br/> 3. ANODE/CATHODE<br/> 4. ANODE<br/> 5. CATHODE<br/> 6. COLLECTOR</p>       |   |

<b>DOCUMENT NUMBER:</b>	<b>98ASB14888C</b>	Electronic versions are uncontrolled except when accessed directly from the Document Repository. Printed versions are uncontrolled except when stamped "CONTROLLED COPY" in red.
<b>DESCRIPTION:</b>	<b>TSOP-6 3.00x1.50x0.90, 0.95P</b>	<b>PAGE 2 OF 2</b>

**onsemi** and **ONSEMI** are trademarks of Semiconductor Components Industries, LLC dba **onsemi** or its subsidiaries in the United States and/or other countries. **onsemi** reserves the right to make changes without further notice to any products herein. **onsemi** makes no warranty, representation or guarantee regarding the suitability of its products for any particular purpose, nor does **onsemi** assume any liability arising out of the application or use of any product or circuit, and specifically disclaims any and all liability, including without limitation special, consequential or incidental damages. **onsemi** does not convey any license under its patent rights nor the rights of others.

**onsemi**, **Onsemi**, and other names, marks, and brands are registered and/or common law trademarks of Semiconductor Components Industries, LLC dba "**onsemi**" or its affiliates and/or subsidiaries in the United States and/or other countries. **onsemi** owns the rights to a number of patents, trademarks, copyrights, trade secrets, and other intellectual property. A listing of **onsemi**'s product/patent coverage may be accessed at [www.onsemi.com/site/pdf/Patent-Marking.pdf](http://www.onsemi.com/site/pdf/Patent-Marking.pdf). **onsemi** reserves the right to make changes at any time to any products or information herein, without notice. The information herein is provided "as-is" and **onsemi** makes no warranty, representation or guarantee regarding the accuracy of the information, product features, availability, functionality, or suitability of its products for any particular purpose, nor does **onsemi** assume any liability arising out of the application or use of any product or circuit, and specifically disclaims any and all liability, including without limitation special, consequential or incidental damages. Buyer is responsible for its products and applications using **onsemi** products, including compliance with all laws, regulations and safety requirements or standards, regardless of any support or applications information provided by **onsemi**. "Typical" parameters which may be provided in **onsemi** data sheets and/or specifications can and do vary in different applications and actual performance may vary over time. All operating parameters, including "Typicals" must be validated for each customer application by customer's technical experts. **onsemi** does not convey any license under any of its intellectual property rights nor the rights of others. **onsemi** products are not designed, intended, or authorized for use as a critical component in life support systems or any FDA Class 3 medical devices or medical devices with a same or similar classification in a foreign jurisdiction or any devices intended for implantation in the human body. Should Buyer purchase or use **onsemi** products for any such unintended or unauthorized application, Buyer shall indemnify and hold **onsemi** and its officers, employees, subsidiaries, affiliates, and distributors harmless against all claims, costs, damages, and expenses, and reasonable attorney fees arising out of, directly or indirectly, any claim of personal injury or death associated with such unintended or unauthorized use, even if such claim alleges that **onsemi** was negligent regarding the design or manufacture of the part. **onsemi** is an Equal Opportunity/Affirmative Action Employer. This literature is subject to all applicable copyright laws and is not for resale in any manner.

## ADDITIONAL INFORMATION

### TECHNICAL PUBLICATIONS:

Technical Library: [www.onsemi.com/design/resources/technical-documentation](http://www.onsemi.com/design/resources/technical-documentation)  
onsemi Website: [www.onsemi.com](http://www.onsemi.com)

### ONLINE SUPPORT: [www.onsemi.com/support](http://www.onsemi.com/support)

For additional information, please contact your local Sales Representative at [www.onsemi.com/support/sales](http://www.onsemi.com/support/sales)