

Bipolar Power Transistors

100 V, 3.0 A, Low $V_{CE(sat)}$

PNP Transistor

PNP TRANSISTOR
-3.0 AMPERES
-100 VOLTS

NSV1C300CT

onsemi's e²PowerEdge family of low $V_{CE(sat)}$ transistors are surface mount devices featuring ultra-low saturation voltage, $V_{CE(sat)}$, and high current gain capability. These are designed for use in lower voltage, high speed switching applications where affordable efficient energy control is important.

Housed in an ultra slim LFAK4 5x6 package, typical applications are DC-DC converters and power management in portable and battery powered products such as cellular and cordless phones, digital cameras and MP3 players where PCB space is at a premium. The LFAK4 5x6 package also contains wettable flanks which are a requirement for the automotive industry's optical inspection methods that are implemented in end applications such as air bag deployment, powertrain control units, and instrument clusters.

Features

- Complement to NSS1C301CT
- Ultra-slim LFAK4 Package (5 x 6 mm) with Wettable Flanks
- NSV Prefix for Automotive and Other Applications Requiring Unique Site and Control Change Requirements; AEC-Q101 Qualified and PPAP Capable
- These Devices are Pb-Free, Halogen Free/BFR Free and are RoHS Compliant

MAXIMUM RATINGS ($T_C = 25\text{ }^\circ\text{C}$ unless otherwise noted)

Symbol	Rating	Value	Unit
V_{CEO}	Collector-Emitter Voltage	-100	Vdc
V_{CBO}	Collector-Base Voltage	-140	Vdc
V_{EB}	Emitter-Base Voltage	-6.0	Vdc
I_B	Base Current - Continuous	-0.5	Adc
I_C	Collector Current - Continuous	-3.0	Adc
I_{CM}	Collector Current - Peak	-6.0	A
P_D	Total Power Dissipation Total P_D @ $T_A = 25\text{ }^\circ\text{C}$ (Note 1) Total P_D @ $T_A = 25\text{ }^\circ\text{C}$ (Note 2)	5.0 1.0	W
T_J, T_{stg}	Operating and Storage Junction Temperature Range	-55 to +150	$^\circ\text{C}$

Stresses exceeding those listed in the Maximum Ratings table may damage the device. If any of these limits are exceeded, device functionality should not be assumed, damage may occur and reliability may be affected.

1. Mounted on 1" sq. (645 sq. mm) Collector pad on FR-4 bd material.
2. Mounted on 0.012" sq. (7.6 sq. mm) Collector pad on FR-4 bd material.

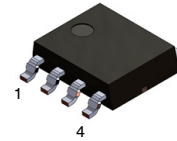

LFAK4 5x6
CASE 760AB

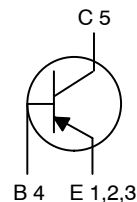

Schematic

MARKING DIAGRAM

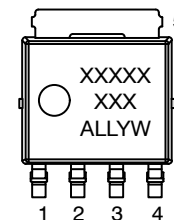

(Top View)

- XXXXXX = Specific Device Code
- A = Assembly Location
- LL = Wafer Lot
- Y = Year
- W = Work Week

ORDERING INFORMATION

See detailed ordering and shipping information in the package dimensions section on page 5 of this data sheet.

NSV1C300CT

THERMAL CHARACTERISTICS

Symbol	Characteristic	Max	Unit
$R_{\theta JA}$	Thermal Resistance, Junction-to-Ambient		$^{\circ}\text{C}/\text{W}$
$R_{\theta JA}$	Junction-to-Ambient on 1" sq. (645 sq. mm) Collector pad on FR-4 bd material	40	
$R_{\theta JA}$	Junction-to-Ambient on 0.012" sq. (7.6 sq. mm) Collector pad on FR-4 bd material	120	

ELECTRICAL CHARACTERISTICS ($T_A = 25^{\circ}\text{C}$ unless otherwise noted)

Symbol	Characteristic	Min	Typ	Max	Unit
--------	----------------	-----	-----	-----	------

OFF CHARACTERISTICS

$V_{(BR)CEO}$	Collector - Emitter Breakdown Voltage ($I_C = -10\text{ mA}$, $I_B = 0$)	-100			Vdc
$V_{(BR)CBO}$	Collector - Base Breakdown Voltage ($I_C = -0.1\text{ mA}$, $I_E = 0$)	-140			Vdc
$V_{(BR)EBO}$	Emitter - Base Breakdown Voltage ($I_E = -0.1\text{ mA}$, $I_C = 0$)	-6.0			Vdc
I_{CBO}	Collector Cutoff Current ($V_{CB} = -140\text{ Vdc}$, $I_E = 0$)			-0.1	μAdc
I_{EBO}	Emitter Cutoff Current ($V_{EB} = -6.0\text{ Vdc}$)			-0.1	μAdc

ON CHARACTERISTICS

h_{FE}	DC Current Gain (Note 3) ($I_C = -0.1\text{ A}$, $V_{CE} = -2.0\text{ V}$) ($I_C = -0.5\text{ A}$, $V_{CE} = -2.0\text{ V}$) ($I_C = -1.0\text{ A}$, $V_{CE} = -2.0\text{ V}$) ($I_C = -3.0\text{ A}$, $V_{CE} = -2.0\text{ V}$)	180 180 120 50		500	-
$V_{CE(sat)}$	Collector - Emitter Saturation Voltage (Note 3) ($I_C = -0.1\text{ A}$, $I_B = -10\text{ mA}$) ($I_C = -1.0\text{ A}$, $I_B = -0.100\text{ A}$) ($I_C = -2.0\text{ A}$, $I_B = -0.200\text{ A}$) ($I_C = -3.0\text{ A}$, $I_B = -0.300\text{ A}$)			-0.070 -0.150 -0.250 -0.400	V
$V_{BE(sat)}$	Base - Emitter Saturation Voltage (Note 3) ($I_C = -1.0\text{ A}$, $I_B = -0.1\text{ A}$)			-1.0	V
$V_{BE(on)}$	Base - Emitter Turn-on Voltage (Note 3) ($I_C = -1.0\text{ A}$, $V_{CE} = -2.0\text{ V}$)			-0.900	V
f_T	Cutoff Frequency ($I_C = -500\text{ mA}$, $V_{CE} = -10\text{ V}$, $f = 100\text{ MHz}$)		100		MHz
C_{ibo}	Input Capacitance ($V_{EB} = -5.0\text{ V}$, $f = 1.0\text{ MHz}$)		360		pF
C_{obo}	Output Capacitance ($V_{CB} = -10\text{ V}$, $f = 1.0\text{ MHz}$)		60		pF

Product parametric performance is indicated in the Electrical Characteristics for the listed test conditions, unless otherwise noted. Product performance may not be indicated by the Electrical Characteristics if operated under different conditions.

3. Pulsed Condition: Pulse Width = 300 msec, Duty Cycle $\leq 2\%$.

NSV1C300CT

TYPICAL CHARACTERISTICS

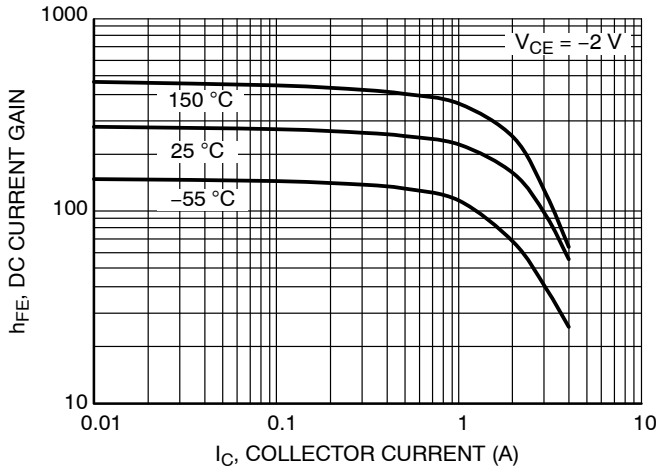

Figure 1. DC Current Gain

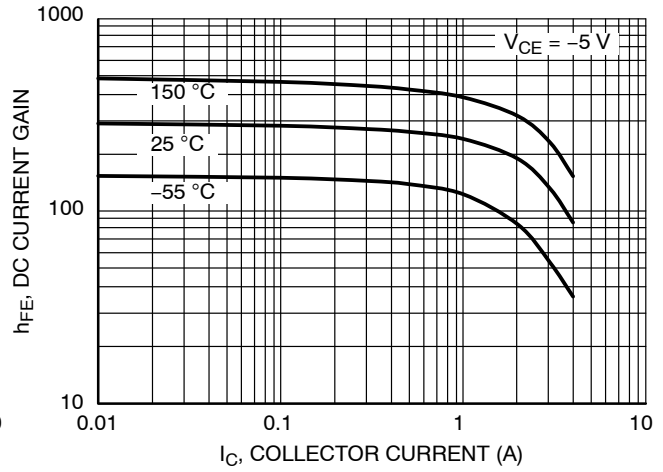

Figure 2. DC Current Gain

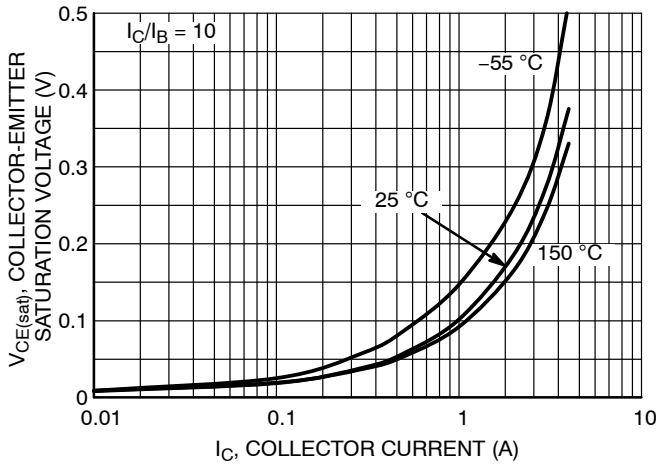

Figure 3. Collector-Emitter Saturation Voltage

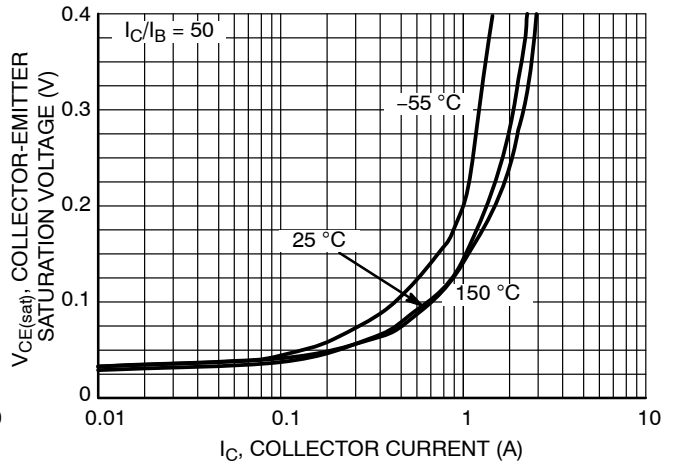

Figure 4. Collector-Emitter Saturation Voltage

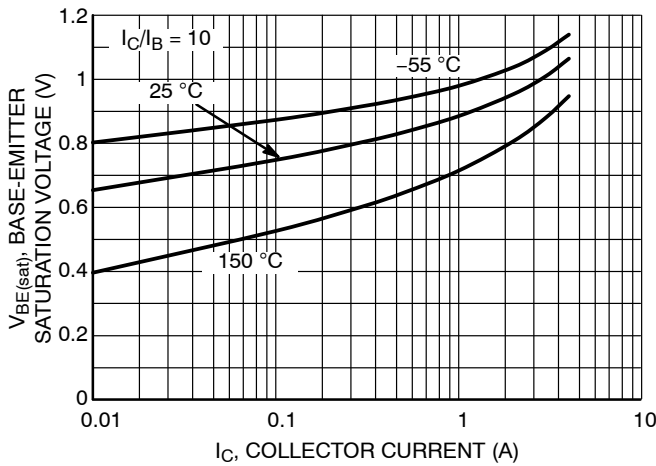

Figure 5. Base-Emitter Saturation Voltage

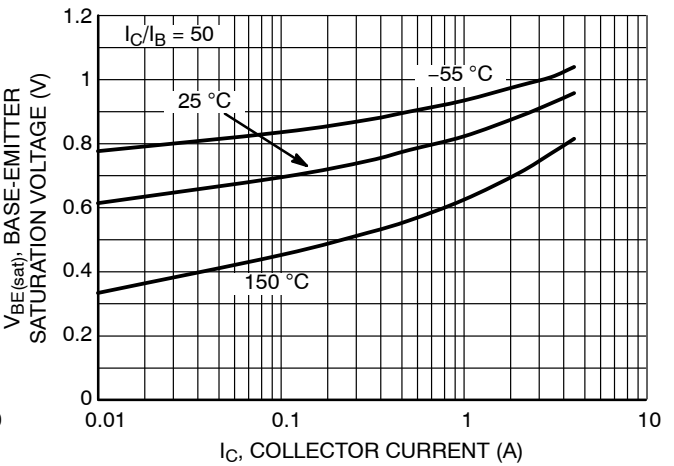

Figure 6. Base-Emitter Saturation Voltage

NSV1C300CT

TYPICAL CHARACTERISTICS (continued)

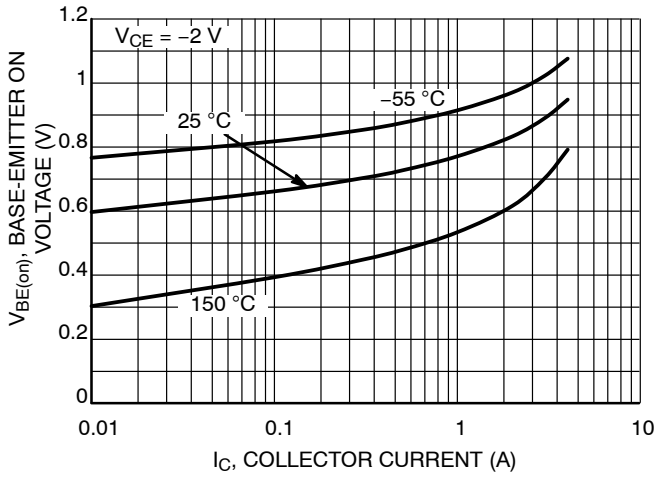

Figure 7. Base-Emitter On Voltage

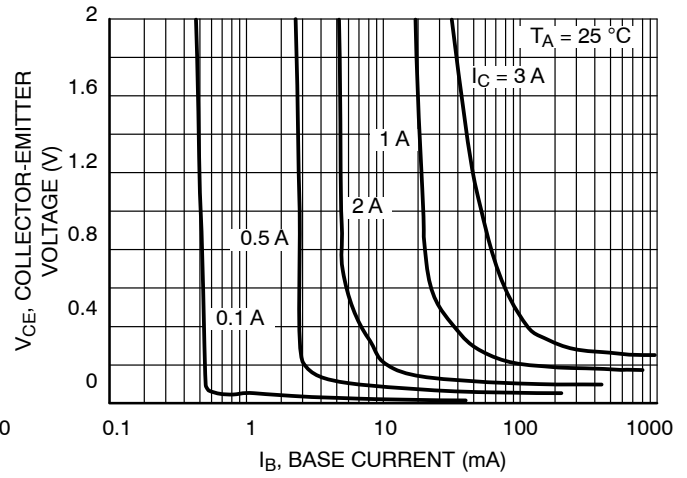

Figure 8. Collector Saturation Region

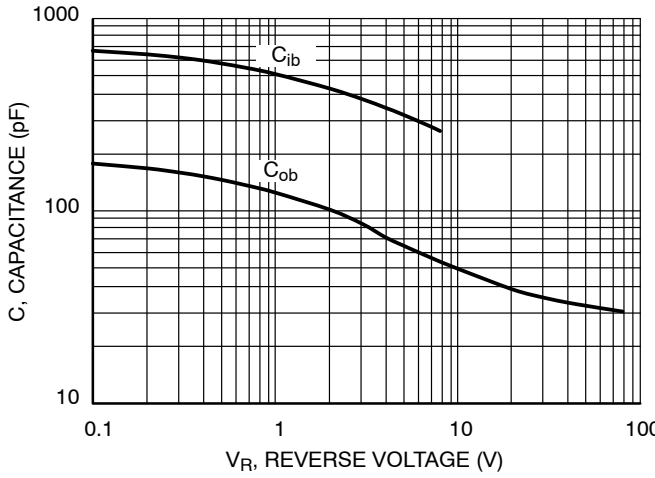

Figure 9. Capacitance

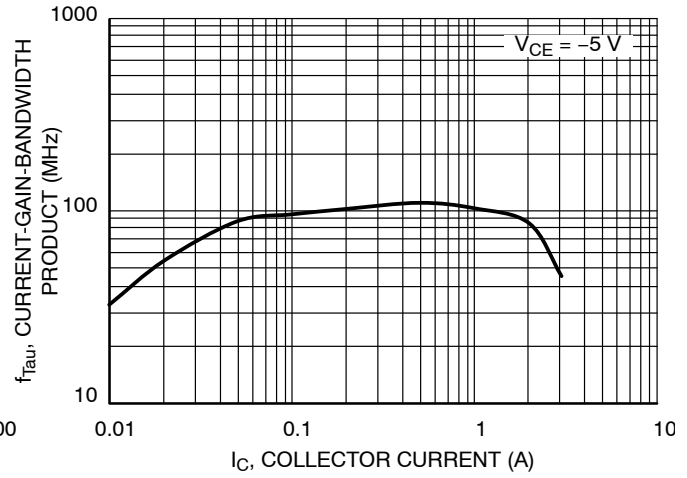

Figure 10. Current-Gain-Bandwidth Product

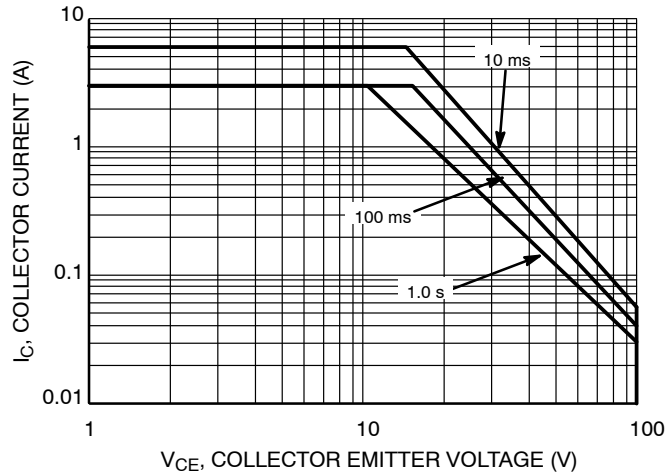

Figure 11. Safe Operating Area

NSV1C300CT

TYPICAL CHARACTERISTICS (continued)

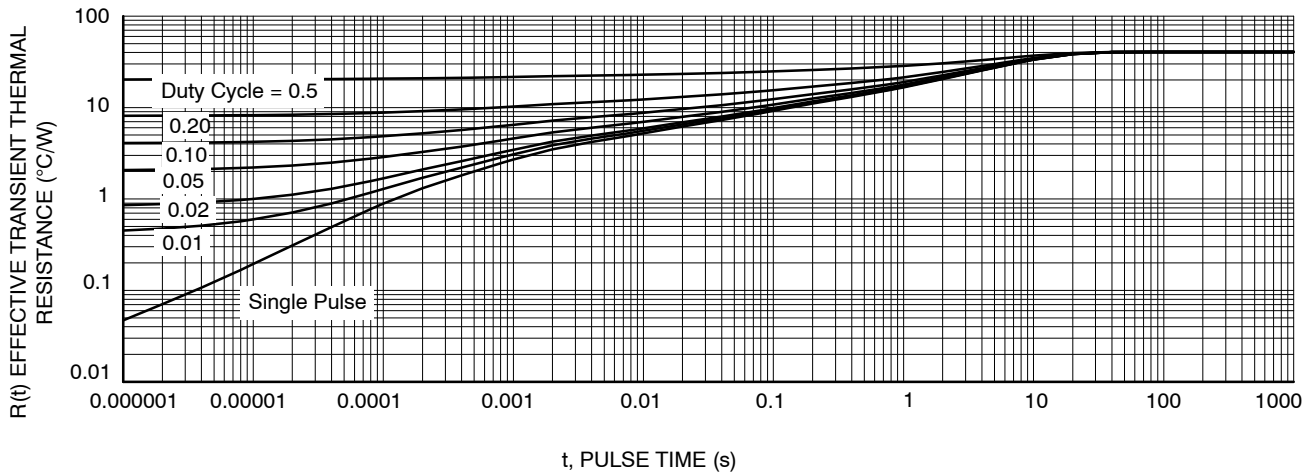

Figure 12. Typical Transient Thermal Response, Junction-to-Ambient

ORDERING INFORMATION

Device	Package	Shipping [†]
NSS1C300CTWG	LFP4K 5x6 (Pb-Free)	3,000 / Tape & Reel
NSV1C300CTWG*	LFP4K 5x6 (Pb-Free)	3,000 / Tape & Reel

[†] For information on tape and reel specifications, including part orientation and tape sizes, please refer to our Tape and Reel Packaging Specifications Brochure, [BRD8011/D](#).

* NSV Prefix for Automotive and Other Applications Requiring Unique Site and Control Change Requirements; AEC-Q101 Qualified and PPAP Capable

NSV1C300CT

REVISION HISTORY

Revision	Description of Changes	Date
1	Replace curve and title on Fig 12 + Rebranded the data sheet to onsemi format.	5/14/2026

This document has undergone updates prior to the inclusion of this revision history table. The changes tracked here only reflect updates made on the noted approval dates.

LFLPAK4 4.90x4.15x1.15MM, 1.27P
CASE 760AB
ISSUE D

DATE 22 MAY 2024

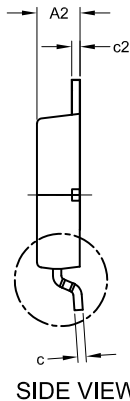
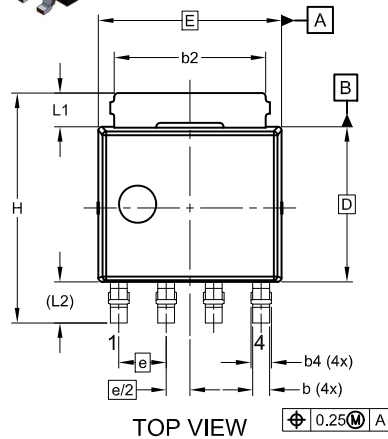
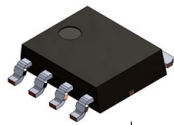

- NOTES:
1. DIMENSIONING AND TOLERANCING PER ASME Y14.5M, 2018.
 2. CONTROLLING DIMENSION: MILLIMETERS.
 3. DIMENSIONS D AND E DO NOT INCLUDE MOLD FLASH, PROTRUSIONS, OR BURRS. MOLD FLASH PROTRUSIONS OR GATE BURRS SHALL NOT EXCEED 0.150mm PER SIDE.
 4. DIMENSIONS D AND E ARE DETERMINED AT THE OUTERMOST EXTREMES OF THE PLASTIC BODY.

TOP VIEW $\text{M} \begin{matrix} \text{A} \\ 0.25 \end{matrix}$

SIDE VIEW

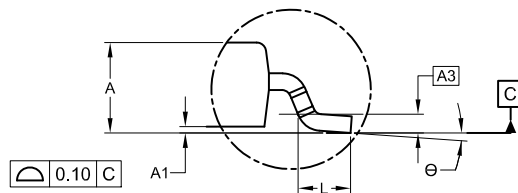

DETAIL 'A'
SCALE: 2:1

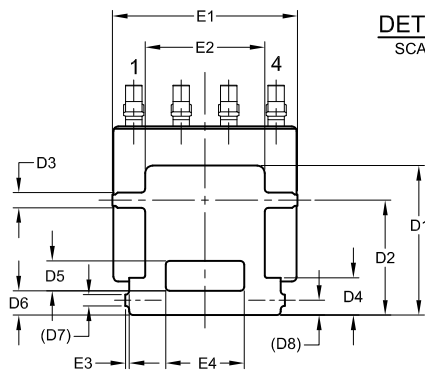

BOTTOM VIEW

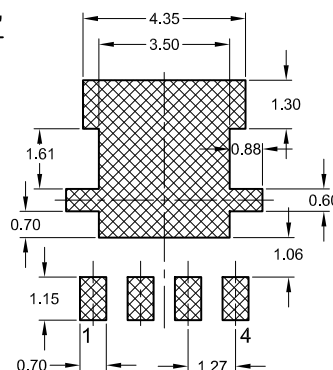

RECOMMENDED LAND PATTERN

*FOR ADDITIONAL INFORMATION ON OUR PB-FREE STRATEGY AND SOLDERING DETAILS, PLEASE DOWNLOAD THE ONSEMI SOLDERING AND MOUNTING TECHNIQUES REFERENCE MANUAL, SOLDERRM/D.

GENERIC MARKING DIAGRAM*

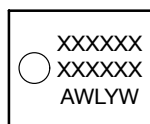

- XXXXXX = Specific Device Code
- A = Assembly Location
- WL = Wafer Lot
- Y = Year
- W = Work Week

*This information is generic. Please refer to device data sheet for actual part marking. Some products may not follow the Generic Marking.

MILLIMETER			
DIM	MIN	NOM	MAX
A	1.10	1.20	1.30
A1	0.00	0.08	0.15
A2	1.10	1.15	1.20
A3	0.25 BSC		
b	0.40	0.45	0.50
b2	3.80	4.10	4.40
b4	0.45	0.55	0.65
c	0.19	0.22	0.25
c2	0.19	0.22	0.25
D	4.15 BSC		
D1	3.80	4.00	4.20
D2	3.00	3.10	3.20
D3	0.30	0.40	0.50
D4	0.90	1.00	1.10
D5	0.70	0.80	0.90
D6	0.55	0.65	0.75
D7	0.31 REF		
D8	0.40 REF		
E	4.90 BSC		
E1	4.85	4.95	5.05
E2	3.10	3.20	3.30
E3	0.00	0.10	0.20
E4	2.00	2.10	2.20
e	1.27 BSC		
e/2	0.635 BSC		
e1	0.40 REF		
H	6.00	6.15	6.30
L	0.50	0.70	0.90
L1	0.80	0.90	1.00
L2	1.10 REF		
Θ	0°	4°	8°

DOCUMENT NUMBER:	98AON82777G	Electronic versions are uncontrolled except when accessed directly from the Document Repository. Printed versions are uncontrolled except when stamped "CONTROLLED COPY" in red.
DESCRIPTION:	LFLPAK4 4.90x4.15x1.15MM, 1.27P	PAGE 1 OF 1

onsemi and ONSEMI are trademarks of Semiconductor Components Industries, LLC dba onsemi or its subsidiaries in the United States and/or other countries. onsemi reserves the right to make changes without further notice to any products herein. onsemi makes no warranty, representation or guarantee regarding the suitability of its products for any particular purpose, nor does onsemi assume any liability arising out of the application or use of any product or circuit, and specifically disclaims any and all liability, including without limitation special, consequential or incidental damages. onsemi does not convey any license under its patent rights nor the rights of others.

onsemi, **Onsemi**, and other names, marks, and brands are registered and/or common law trademarks of Semiconductor Components Industries, LLC dba "**onsemi**" or its affiliates and/or subsidiaries in the United States and/or other countries. **onsemi** owns the rights to a number of patents, trademarks, copyrights, trade secrets, and other intellectual property. A listing of **onsemi**'s product/patent coverage may be accessed at www.onsemi.com/site/pdf/Patent-Marking.pdf. **onsemi** reserves the right to make changes at any time to any products or information herein, without notice. The information herein is provided "as-is" and **onsemi** makes no warranty, representation or guarantee regarding the accuracy of the information, product features, availability, functionality, or suitability of its products for any particular purpose, nor does **onsemi** assume any liability arising out of the application or use of any product or circuit, and specifically disclaims any and all liability, including without limitation special, consequential or incidental damages. Buyer is responsible for its products and applications using **onsemi** products, including compliance with all laws, regulations and safety requirements or standards, regardless of any support or applications information provided by **onsemi**. "Typical" parameters which may be provided in **onsemi** data sheets and/or specifications can and do vary in different applications and actual performance may vary over time. All operating parameters, including "Typicals" must be validated for each customer application by customer's technical experts. **onsemi** does not convey any license under any of its intellectual property rights nor the rights of others. **onsemi** products are not designed, intended, or authorized for use as a critical component in life support systems or any FDA Class 3 medical devices or medical devices with a same or similar classification in a foreign jurisdiction or any devices intended for implantation in the human body. Should Buyer purchase or use **onsemi** products for any such unintended or unauthorized application, Buyer shall indemnify and hold **onsemi** and its officers, employees, subsidiaries, affiliates, and distributors harmless against all claims, costs, damages, and expenses, and reasonable attorney fees arising out of, directly or indirectly, any claim of personal injury or death associated with such unintended or unauthorized use, even if such claim alleges that **onsemi** was negligent regarding the design or manufacture of the part. **onsemi** is an Equal Opportunity/Affirmative Action Employer. This literature is subject to all applicable copyright laws and is not for resale in any manner.

ADDITIONAL INFORMATION

TECHNICAL PUBLICATIONS:

Technical Library: www.onsemi.com/design/resources/technical-documentation
onsemi Website: www.onsemi.com

ONLINE SUPPORT: www.onsemi.com/support

For additional information, please contact your local Sales Representative at www.onsemi.com/support/sales