

Silicon Carbide (SiC) MOSFET - EliteSiC, 16 mohm, 650 V, M3S, T2PAK

NVT2016N065M3S

Features

- Typ. $R_{DS(on)} = 16\text{ m}\Omega @ V_{GS} = 18\text{ V}$
- Low Effective Output Capacitance
- Ultra Low Gate Charge
- 100% UIS Tested
- Qualified According to AECQ101
- This Device is Halide Free and RoHS Compliant with Exemption 7a, Pb-Free 2LI (on second level interconnection)

Applications

- Automotive On and Off Board Charger
- Automotive DC-DC Converter for EV-HEV

MAXIMUM RATINGS ($T_J = 25\text{ }^\circ\text{C}$ unless otherwise noted)

Parameter	Symbol	Value	Unit
Drain-to-Source Voltage	V_{DSS}	650	V
Gate-to-Source Voltage	V_{GS}	-8/+22	V
Continuous Drain Current	$T_C = 25\text{ }^\circ\text{C}$	I_D	85 A
Power Dissipation		P_D	333 W
Continuous Drain Current	$T_C = 100\text{ }^\circ\text{C}$	I_D	62 A
Power Dissipation		P_D	167 W
Pulsed Drain Current (Note 1)	$T_C = 25\text{ }^\circ\text{C}$ $t_p = 100\text{ }\mu\text{s}$	I_{DM}	178 A
Continuous Source-Drain Current (Body Diode)	$T_C = 25\text{ }^\circ\text{C}$ $V_{GS} = -3\text{ V}$	I_S	49 A
	$T_C = 100\text{ }^\circ\text{C}$ $V_{GS} = -3\text{ V}$		29
Pulsed Source-Drain Current (Body Diode) (Note 1)	$T_C = 25\text{ }^\circ\text{C}$ $V_{GS} = -3\text{ V}$ $t_p = 100\text{ }\mu\text{s}$	I_{SM}	198 A
Single Pulse Avalanche Energy ($I_{LPK} = 60\text{ A}$, $L = 0.1\text{ mH}$) (Note 2)	E_{AS}	180	mJ
Operating Junction and Storage Temperature Range	T_J, T_{stg}	-55 to +175	$^\circ\text{C}$
Lead Temperature for Soldering Purposes (1/8" from case for 10 seconds)	T_L	245	$^\circ\text{C}$

Stresses exceeding those listed in the Maximum Ratings table may damage the device. If any of these limits are exceeded, device functionality should not be assumed, damage may occur and reliability may be affected.

1. Single pulse, limited by max junction temperature.
2. E_{AS} of 180 mJ is based on starting $T_J = 25\text{ }^\circ\text{C}$, $L = 0.1\text{ mH}$, $I_{AS} = 60\text{ A}$, $V_{DD} = 100\text{ V}$, $V_{GS} = 18\text{ V}$.

$V_{(BR)DSS}$	$R_{DS(ON)}$ TYP	I_D MAX
650 V	16 m Ω @ $V_{GS} = 18\text{ V}$	85 A

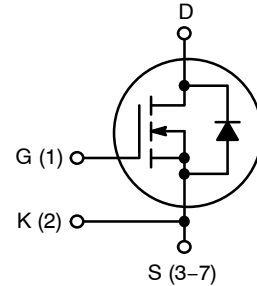

N-CHANNEL MOSFET

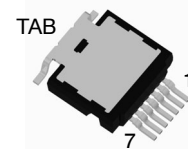

T2PAK-7
CASE 763AC

MARKING DIAGRAM

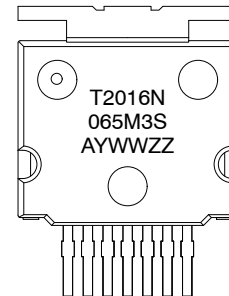

NVT2016N065M3S = Specific Device Code
 A = Assembly Site
 WW = Work Week Number
 Y = Year of Production, Last Number
 ZZ = Assembly Lot Number, Last Two Numbers

ORDERING INFORMATION

Device	Package	Shipping [†]
NVT2016N065M3S	T2PAK-7L	800 / Tape & Reel

[†] For information on tape and reel specifications, including part orientation and tape sizes, please refer to our Tape and Reel Packaging Specification Brochure, [BRD8011/D](http://www.onsemi.com/BRD8011/D).

NVT2016N065M3S

THERMAL CHARACTERISTICS

Parameter	Symbol	Value	Unit
Thermal Resistance, Junction-to-Case (Note 3)	$R_{\theta JC}$	0.45	$^{\circ}\text{C}/\text{W}$

3. The entire application environment impacts the thermal resistance values shown, they are not constants and are only valid for the particular conditions noted.

RECOMMENDED OPERATING CONDITIONS

Parameter	Symbol	Value	Unit
Operation Values of Gate-to-Source Voltage	V_{GSop}	-3/18	V

Functional operation above the stresses listed in the Recommended Operating Ranges is not implied. Extended exposure to stresses beyond the Recommended Operating Ranges limits may affect device reliability.

ELECTRICAL CHARACTERISTICS ($T_J = 25^{\circ}\text{C}$ unless otherwise specified)

Parameter	Symbol	Test Conditions	Min	Typ	Max	Unit
-----------	--------	-----------------	-----	-----	-----	------

OFF CHARACTERISTICS

Drain-to-Source Breakdown Voltage	$V_{(BR)DSS}$	$V_{GS} = 0\text{ V}, I_D = 1\text{ mA}, T_J = 25^{\circ}\text{C}$	650	-	-	V
Zero Gate Voltage Drain Current	I_{DSS}	$V_{DS} = 650\text{ V}, T_J = 25^{\circ}\text{C}$	-	-	10	μA
		$V_{DS} = 650\text{ V}, T_J = 175^{\circ}\text{C}$ (Note 5)	-	-	500	μA
Gate-to-Source Leakage Current	I_{GSS}	$V_{GS} = -10\text{ V}, V_{DS} = 0\text{ V}$	-1	-	-	μA
		$V_{GS} = +22\text{ V}, V_{DS} = 0\text{ V}$	-	-	1	

ON CHARACTERISTICS

Drain-to-Source On Resistance	$R_{DS(on)}$	$V_{GS} = 18\text{ V}, I_D = 29\text{ A}, T_J = 25^{\circ}\text{C}$	-	17	23.4	m Ω
		$V_{GS} = 18\text{ V}, I_D = 29\text{ A}, T_J = 175^{\circ}\text{C}$ (Note 5)	-	26	-	
		$V_{GS} = 15\text{ V}, I_D = 29\text{ A}, T_J = 25^{\circ}\text{C}$	-	22	-	
		$V_{GS} = 15\text{ V}, I_D = 29\text{ A}, T_J = 175^{\circ}\text{C}$ (Note 5)	-	29	-	
Gate Threshold Voltage	$V_{GS(TH)}$	$V_{GS} = V_{DS}, I_D = 15\text{ mA}, T_J = 25^{\circ}\text{C}$	2.0	2.7	4.0	V
Forward Transconductance	g_{FS}	$V_{DS} = 10\text{ V}, I_D = 29\text{ A}$ (Note 5)	-	19	-	S

CHARGES, CAPACITANCES & GATE RESISTANCE

Input Capacitance	C_{ISS}	$V_{DS} = 400\text{ V}, V_{GS} = 0\text{ V}, f = 1\text{ MHz}$ (Note 5)	-	2735	-	pF
Output Capacitance	C_{OSS}		-	208	-	
Reverse Transfer Capacitance	C_{RSS}		-	18	-	
Total Gate Charge	$Q_{G(TOT)}$	$V_{DD} = 400\text{ V}, I_D = 29\text{ A}, V_{GS} = -3/18\text{ V}$ (Note 5)	-	100	-	nC
Gate-to-Source Charge	Q_{GS}		-	26	-	
Gate-to-Drain Charge	Q_{GD}		-	25	-	
Gate Resistance	R_G	$f = 1\text{ MHz}$	-	2.8	-	Ω

SWITCHING CHARACTERISTICS

Turn-On Delay Time	$t_{d(ON)}$	$V_{GS} = -3/18\text{ V}, V_{DD} = 400\text{ V}, I_D = 30\text{ A}, R_G = 4.7\ \Omega, T_J = 25^{\circ}\text{C}, L_{stray} = 13\text{ nH}$ (Notes 4, 5)	-	25	-	ns
Turn-Off Delay Time	$t_{d(OFF)}$		-	54	-	
Rise Time	t_r		-	17	-	
Fall Time	t_f		-	10.5	-	
Turn-On Switching Loss	E_{ON}		-	146	-	μJ
Turn-Off Switching Loss	E_{OFF}		-	55	-	
Total Switching Loss	E_{TOT}		-	201	-	

NVT2016N065M3S

ELECTRICAL CHARACTERISTICS ($T_J = 25\text{ }^\circ\text{C}$ unless otherwise specified) (continued)

Parameter	Symbol	Test Conditions	Min	Typ	Max	Unit
SWITCHING CHARACTERISTICS						
Turn-On Delay Time	$t_{d(ON)}$	$V_{GS} = -3/18\text{ V}$, $V_{DD} = 400\text{ V}$, $I_D = 30\text{ A}$, $R_G = 4.7\text{ }\Omega$, $T_J = 175\text{ }^\circ\text{C}$, $L_{stray} = 13\text{ nH}$ (Notes 4, 5)	-	30.6	-	ns
Turn-Off Delay Time	$t_{d(OFF)}$		-	63	-	
Rise Time	t_r		-	16	-	
Fall Time	t_f		-	11.5	-	
Turn-On Switching Loss	E_{ON}		-	150	-	μJ
Turn-Off Switching Loss	E_{OFF}		-	65	-	
Total Switching Loss	E_{TOT}		-	216	-	

SOURCE-TO-DRAIN DIODE CHARACTERISTICS

Forward Diode Voltage	V_{SD}	$I_{SD} = 29\text{ A}$, $V_{GS} = -3\text{ V}$, $T_J = 25\text{ }^\circ\text{C}$	-	4.5	6.0	V
		$I_{SD} = 29\text{ A}$, $V_{GS} = -3\text{ V}$, $T_J = 175\text{ }^\circ\text{C}$ (Note 5)	-	4.2	-	
Reverse Recovery Time	t_{RR}	$V_{GS} = -3\text{ V}$, $I_S = 29\text{ A}$, $dI/dt = 1000\text{ A}/\mu\text{s}$, $V_{DS} = 400\text{ V}$, $T_J = 25\text{ }^\circ\text{C}$ (Note 5)	-	23	-	ns
Charge Time	t_a		-	13	-	
Discharge Time	t_b		-	10	-	
Reverse Recovery Charge	Q_{RR}		-	146	-	nC
Reverse Recovery Energy	E_{REC}		-	12	-	μJ
Peak Reverse Recovery Current	I_{RRM}		-	11	-	A

Product parametric performance is indicated in the Electrical Characteristics for the listed test conditions, unless otherwise noted. Product performance may not be indicated by the Electrical Characteristics if operated under different conditions.

4. E_{ON}/E_{OFF} result is with body diode.

5. Defined by design, not subject to production test.

TYPICAL CHARACTERISTICS

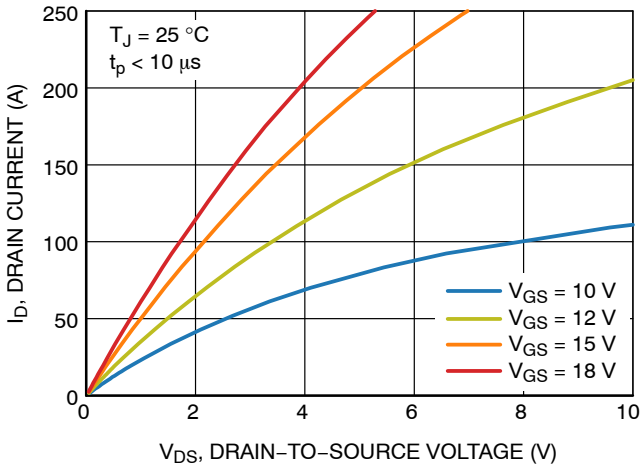

Figure 1. Output Characteristics

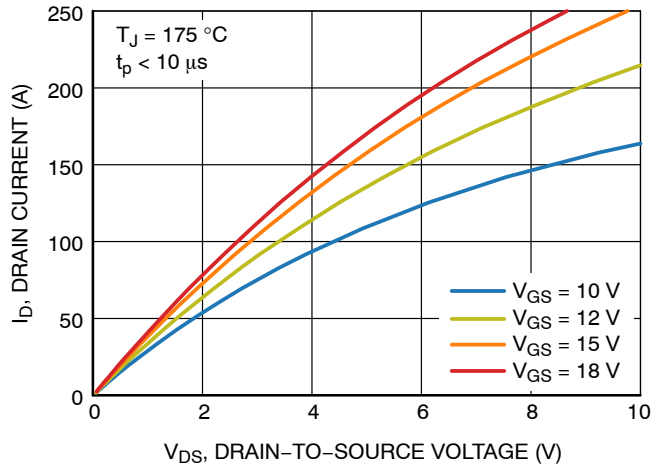

Figure 2. Output Characteristics

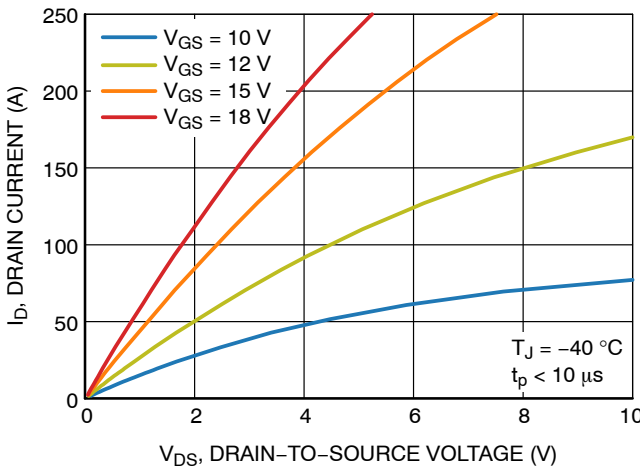

Figure 3. Output Characteristics

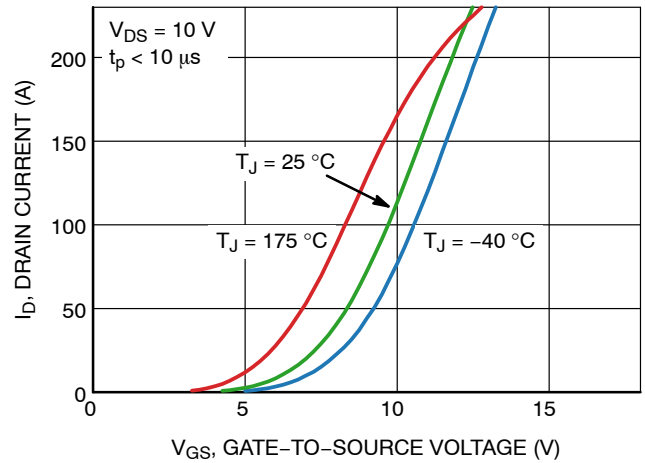

Figure 4. I_D vs. V_{GS}

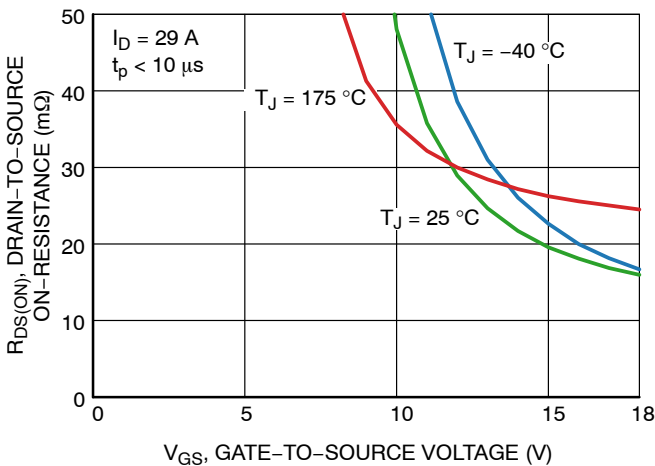

Figure 5. $R_{DS(ON)}$ vs. V_{GS}

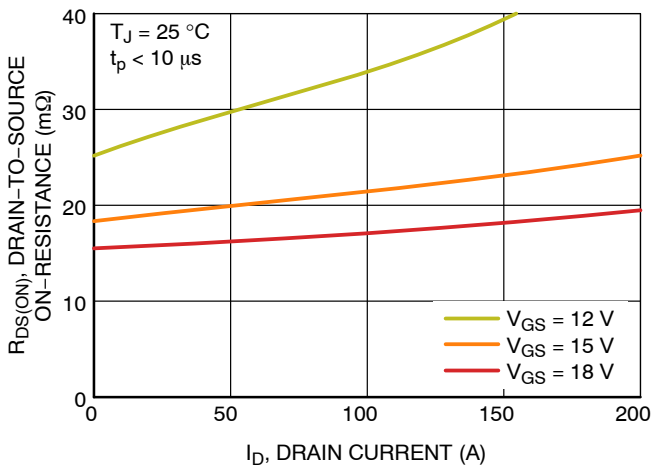

Figure 6. $R_{DS(ON)}$ vs. I_D

TYPICAL CHARACTERISTICS

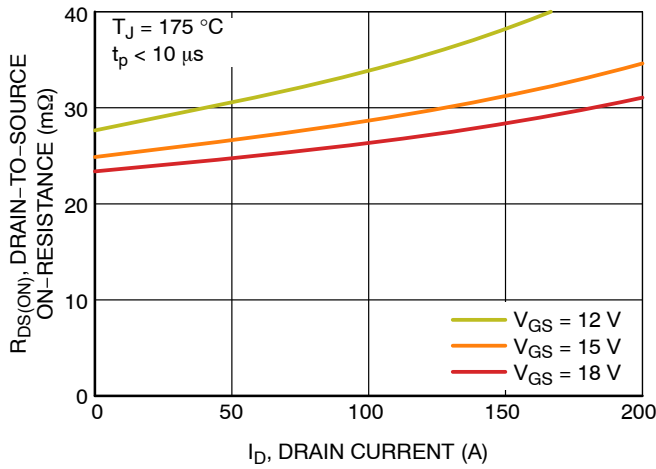

Figure 7. $R_{DS(ON)}$ vs. I_D

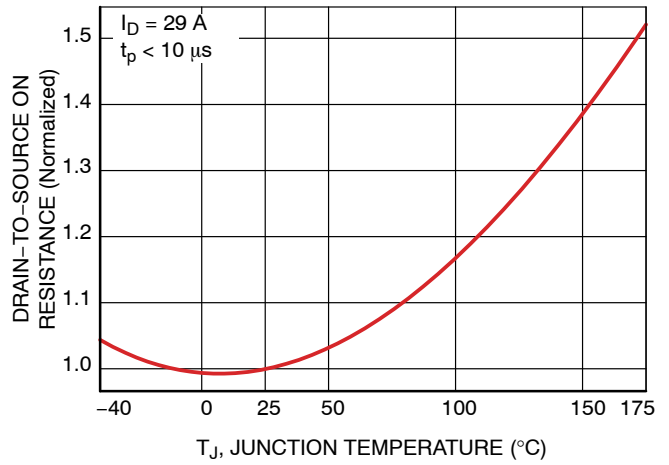

Figure 8. $R_{DS(ON)}$ vs. T_J

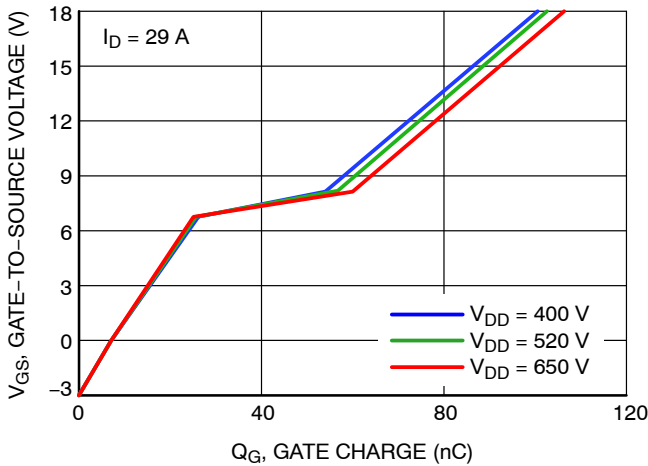

Figure 9. Gate Charge Characteristics

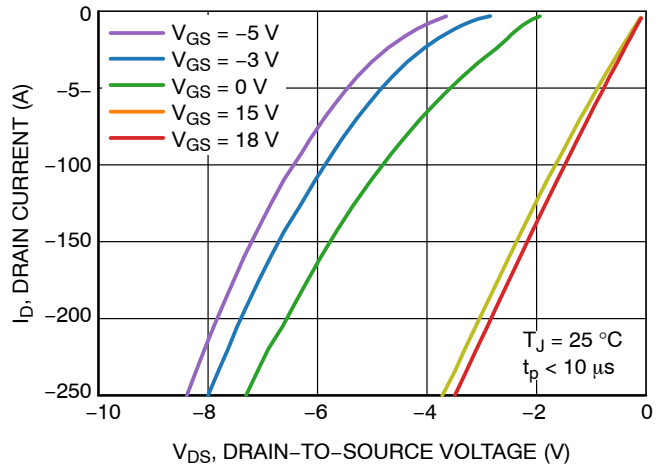

Figure 10. I_D vs. V_{DS}

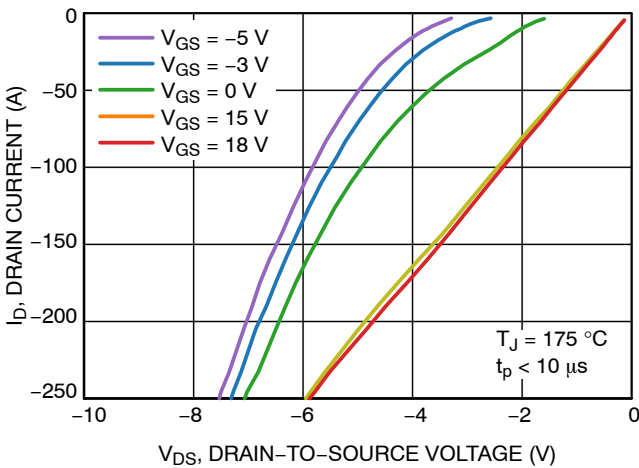

Figure 11. I_D vs. V_{DS}

TYPICAL CHARACTERISTICS

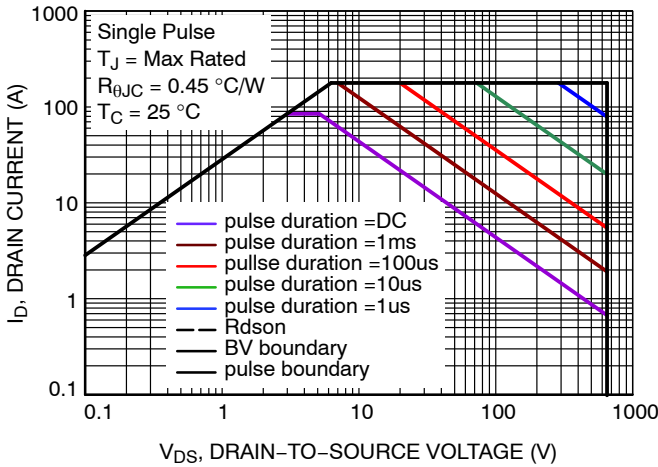

Figure 12. Safe Operating Area

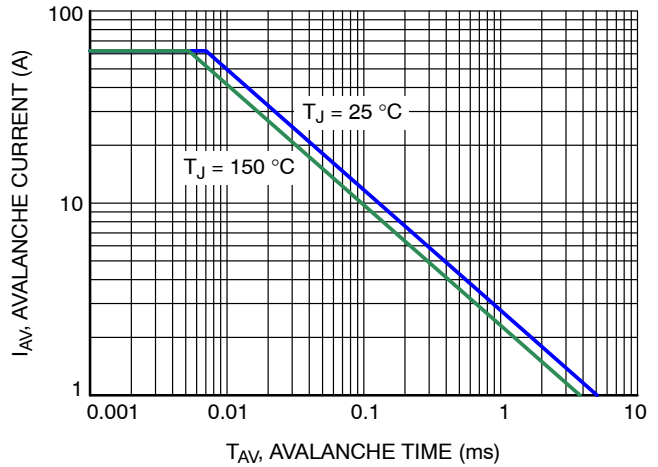

Figure 13. Avalanche Current vs. Pulse Time (UIS)

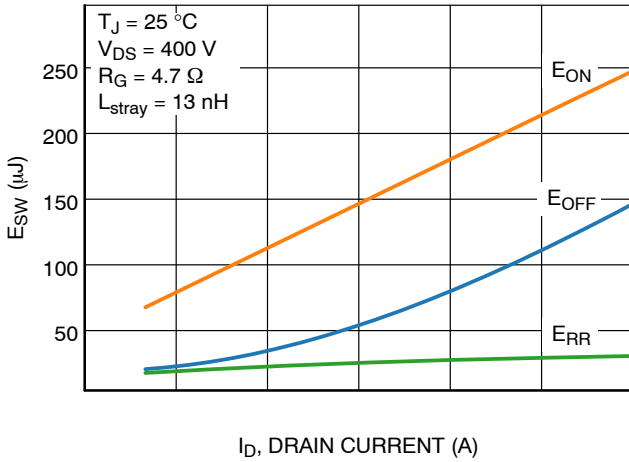

Figure 14. E_{SW} vs. I_D

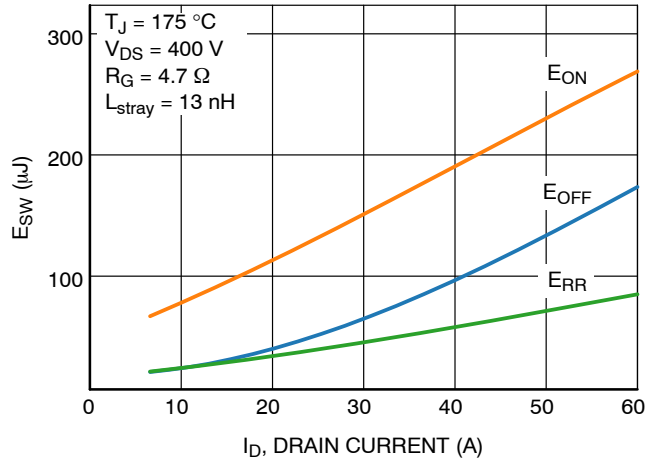

Figure 15. E_{SW} vs. I_D

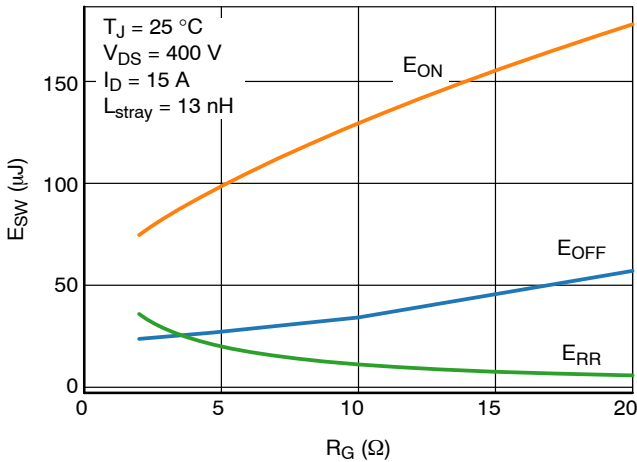

Figure 16. E_{SW} vs. R_G

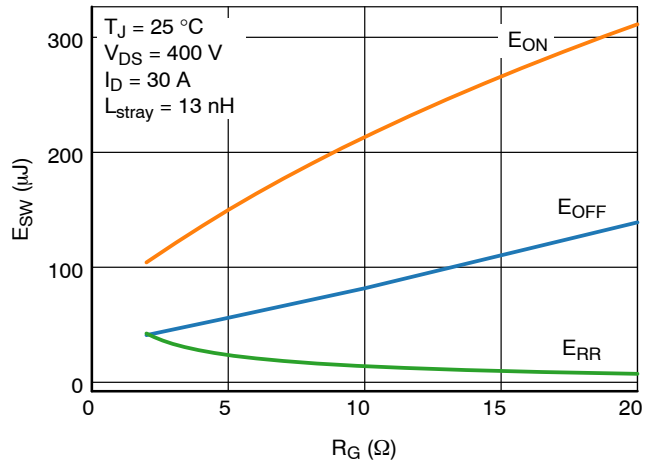

Figure 17. E_{SW} vs. R_G

NVT2016N065M3S

TYPICAL CHARACTERISTICS

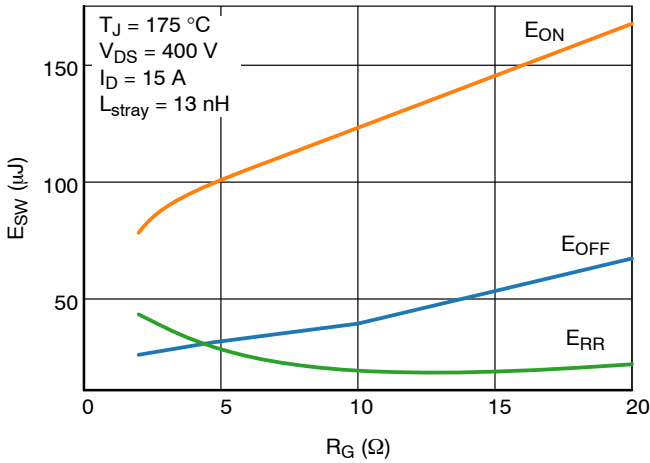

Figure 18. E_{SW} vs. R_G

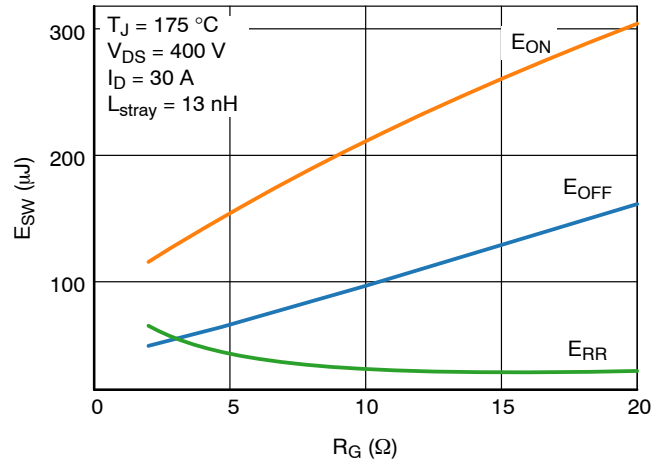

Figure 19. E_{SW} vs. R_G

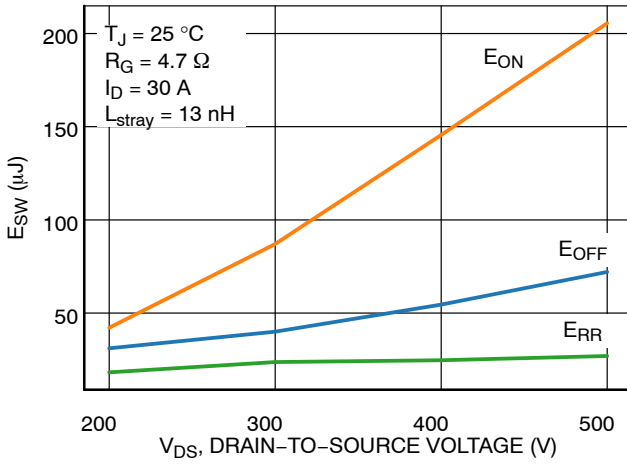

Figure 20. E_{SW} vs. V_{DS}

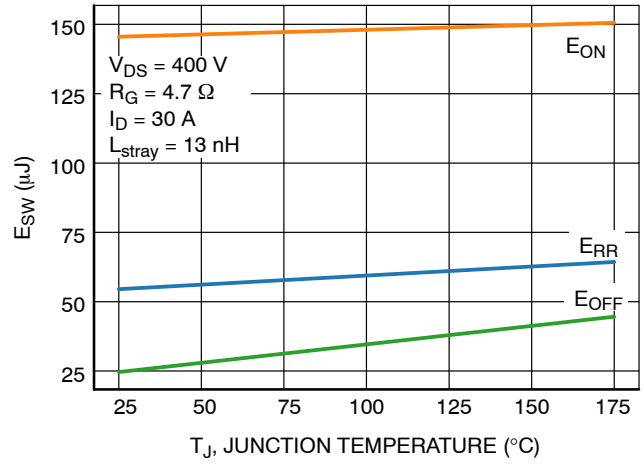

Figure 21. E_{SW} vs. T_J

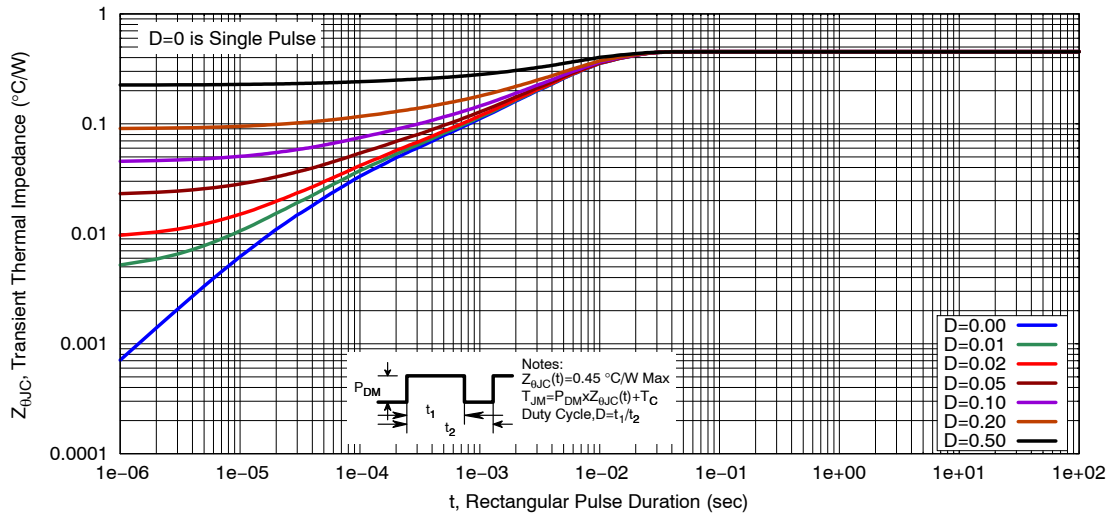
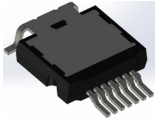

Figure 22. Thermal Response Characteristics

NVT2016N065M3S

REVISION HISTORY

Revision	Description of Changes	Date
0	Initial data sheet release.	09/29/2025
1	Edits to a page 1 bullet and figures 5 and 8	10/10/2025



T2PAK-7 11.80x14.00x3.50, 1.27P
CASE 763AC
ISSUE A

DATE 20 JUN 2025

- NOTES:
- DIMENSIONING AND TOLERANCING AS PER ASME Y14.5M, 2018.
 - CONTROLLING DIMENSION: MILLIMETERS.
 - DIMENSIONS b, b2, b3 AND c TO BE MEASURED ON FLAT SECTION OF THE LEAD BETWEEN 0.13 AND 0.25mm FROM LEAD TIP.
 - COPLANARITY APPLIES TO THE EXPOSED PAD AS WELL AS THE TERMINALS.
 - POSITIONAL TOLERANCE APPLIES TO THE TERMINALS AND EXPOSED PAD.
 - A1 IS DEFINED AS THE VERTICAL DISTANCE FROM THE SEATING PLANE TO THE LOWEST POINT OF THE PACKAGE BODY.
 - DIMENSIONS D AND E ARE DETERMINED AT THE OUTERMOST EXTREMES OF THE PLASTIC BODY.
 - ALLOWABLE ENCRACHED FLASH ON HEAT SINK AREA MAXIMUM OF 0.05mm.
 - EJECTOR PINS ϕ 12.5mm REF.

MILLIMETERS			
DIM	MIN	NOM	MAX
A	3.53	3.63	3.73
A1	0.07	0.13	0.18
A2	3.40	3.50	3.60
b	0.50	0.60	0.70
b2	0.50	0.75	1.00
b3	0.80	0.90	1.00
c	0.40	0.50	0.60
c2	0.40	0.50	0.60
D	11.80 BSC		
D2	8.90	9.00	9.10
D3	3.00	3.10	3.20
D4	3.80	3.90	4.00
D5	2.10	2.20	2.30
E	14.00 BSC		
E2	12.30	12.40	12.50
e	1.27 BSC		

MILLIMETERS			
DIM	MIN	NOM	MAX
H	18.00	18.50	19.00
H1	13.80	14.00	14.20
L	2.42	2.52	2.62
L1	4.53 REF		
L2	0.25 BSC		
L3	3.00	3.10	3.20
R	0.80	---	1.00
θ	0°	---	8°
ϕ 1	0°	---	8°
TOLERANCE FORM AND POSITION			
aaa	0.10		
bbb	0.10		
ccc	0.10		
ddd	0.05		
eee	0.05		

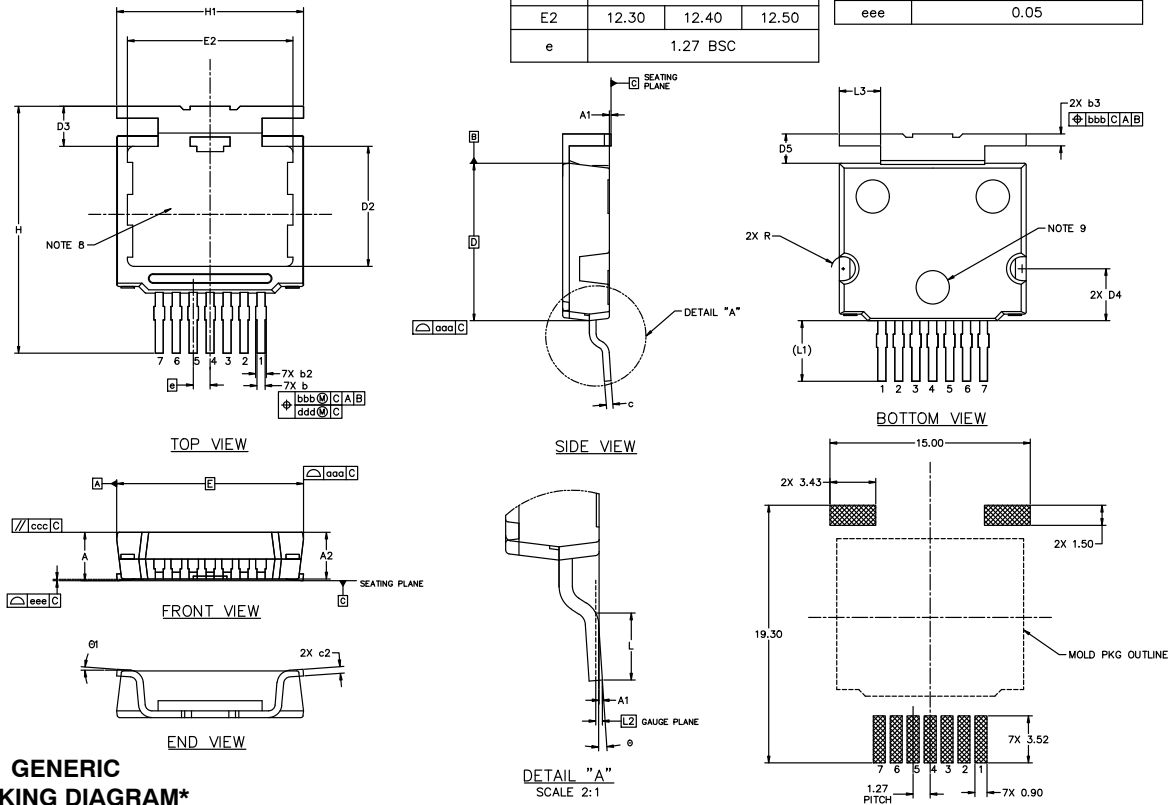

GENERIC MARKING DIAGRAM*

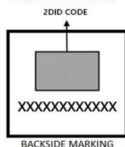

XXXX = Specific Device Code
 A = Assembly Location
 Y = Year
 WW = Work Week
 ZZ = Assembly Lot Code

*This information is generic. Please refer to device data sheet for actual part marking. Pb-Free indicator, "G" or microdot "m", may or may not be present. Some products may not follow the Generic Marking.

RECOMMENDED MOUNTING FOOTPRINT

*For additional information on our Pb-Free strategy and soldering details, please download the onsemi Soldering and Mounting Techniques Reference Manual, SOLDERRM/D.

DOCUMENT NUMBER:	98AON60982H	Electronic versions are uncontrolled except when accessed directly from the Document Repository. Printed versions are uncontrolled except when stamped "CONTROLLED COPY" in red.
DESCRIPTION:	T2PAK-7 11.80x14.00x3.50, 1.27P	PAGE 1 OF 1

onsemi and ONSEMI are trademarks of Semiconductor Components Industries, LLC dba onsemi or its subsidiaries in the United States and/or other countries. onsemi reserves the right to make changes without further notice to any products herein. onsemi makes no warranty, representation or guarantee regarding the suitability of its products for any particular purpose, nor does onsemi assume any liability arising out of the application or use of any product or circuit, and specifically disclaims any and all liability, including without limitation special, consequential or incidental damages. onsemi does not convey any license under its patent rights nor the rights of others.

onsemi, **Onsemi**, and other names, marks, and brands are registered and/or common law trademarks of Semiconductor Components Industries, LLC dba "**onsemi**" or its affiliates and/or subsidiaries in the United States and/or other countries. **onsemi** owns the rights to a number of patents, trademarks, copyrights, trade secrets, and other intellectual property. A listing of **onsemi**'s product/patent coverage may be accessed at www.onsemi.com/site/pdf/Patent-Marking.pdf. **onsemi** reserves the right to make changes at any time to any products or information herein, without notice. The information herein is provided "as-is" and **onsemi** makes no warranty, representation or guarantee regarding the accuracy of the information, product features, availability, functionality, or suitability of its products for any particular purpose, nor does **onsemi** assume any liability arising out of the application or use of any product or circuit, and specifically disclaims any and all liability, including without limitation special, consequential or incidental damages. Buyer is responsible for its products and applications using **onsemi** products, including compliance with all laws, regulations and safety requirements or standards, regardless of any support or applications information provided by **onsemi**. "Typical" parameters which may be provided in **onsemi** data sheets and/or specifications can and do vary in different applications and actual performance may vary over time. All operating parameters, including "Typicals" must be validated for each customer application by customer's technical experts. **onsemi** does not convey any license under any of its intellectual property rights nor the rights of others. **onsemi** products are not designed, intended, or authorized for use as a critical component in life support systems or any FDA Class 3 medical devices or medical devices with a same or similar classification in a foreign jurisdiction or any devices intended for implantation in the human body. Should Buyer purchase or use **onsemi** products for any such unintended or unauthorized application, Buyer shall indemnify and hold **onsemi** and its officers, employees, subsidiaries, affiliates, and distributors harmless against all claims, costs, damages, and expenses, and reasonable attorney fees arising out of, directly or indirectly, any claim of personal injury or death associated with such unintended or unauthorized use, even if such claim alleges that **onsemi** was negligent regarding the design or manufacture of the part. **onsemi** is an Equal Opportunity/Affirmative Action Employer. This literature is subject to all applicable copyright laws and is not for resale in any manner.

ADDITIONAL INFORMATION

TECHNICAL PUBLICATIONS:

Technical Library: www.onsemi.com/design/resources/technical-documentation
onsemi Website: www.onsemi.com

ONLINE SUPPORT: www.onsemi.com/support

For additional information, please contact your local Sales Representative at www.onsemi.com/support/sales