

# Intelligent Power Module (IPM)

600 V, 15 A



ON Semiconductor®

[www.onsemi.com](http://www.onsemi.com)

## STK531U394C-E

The STK531U394C-E is a fully-integrated inverter power stage consisting of a high-voltage driver, six IGBT's and a thermistor, suitable for driving permanent magnet synchronous (PMSM) motors, brushless-DC (BLDC) motors and AC asynchronous motors. The IGBT's are configured in a 3-phase bridge with separate emitter connections for the lower legs for maximum flexibility in the choice of control algorithm.

The power stage has a full range of protection functions including cross-conduction protection, external shutdown and under-voltage lockout functions. Output stage uses IGBT/FRD technology and implements Under Voltage Protection (UVP) and Over Current Protection (OCP: Shunt Resistor internal) with a Fault Detection output flag. Internal Boost diodes are provided for high side gate boost drive.

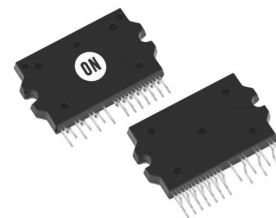

SIP29 44x26.5  
CASE 127ET

### Features

- Three-phase 15 A / 600 V IGBT Module with Integrated Drivers
- Typical Values (Upper Side at 15 A) :  $V_{CE(sat)} = 1.8 \text{ V}$ ,  $V_F = 2.0 \text{ V}$
- 44.0 mm × 26.5 mm Single In-line Package with Vertical LF Type
- Cross-conduction Protection
- Adjustable Over-current Protection Level
- Integrated Bootstrap Diodes and Resistors
- These Devices are Pb-Free and are RoHS Compliant

### Certification

- UL1557 (File number : E339285)

### Typical Applications

- Industrial Pumps
- Industrial Fans
- Industrial Automation
- Heat Pumps, Home Appliances

### MARKING DIAGRAM



STK531U394C = Specific Device Code  
 A = Year  
 B = Month  
 C = Production Site  
 DD = Factory Lot code  
 Device marking is on package underside

### ORDERING INFORMATION

See detailed ordering and shipping information in the package dimensions section on page 12 of this data sheet.

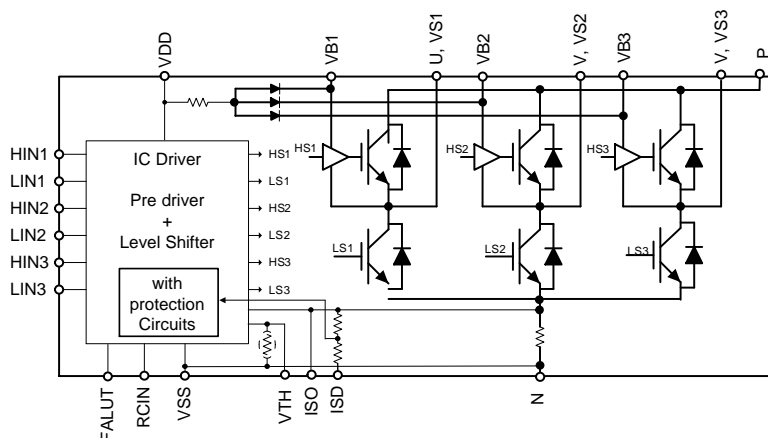

Figure 1. Functional Diagram

## STK531U394C-E

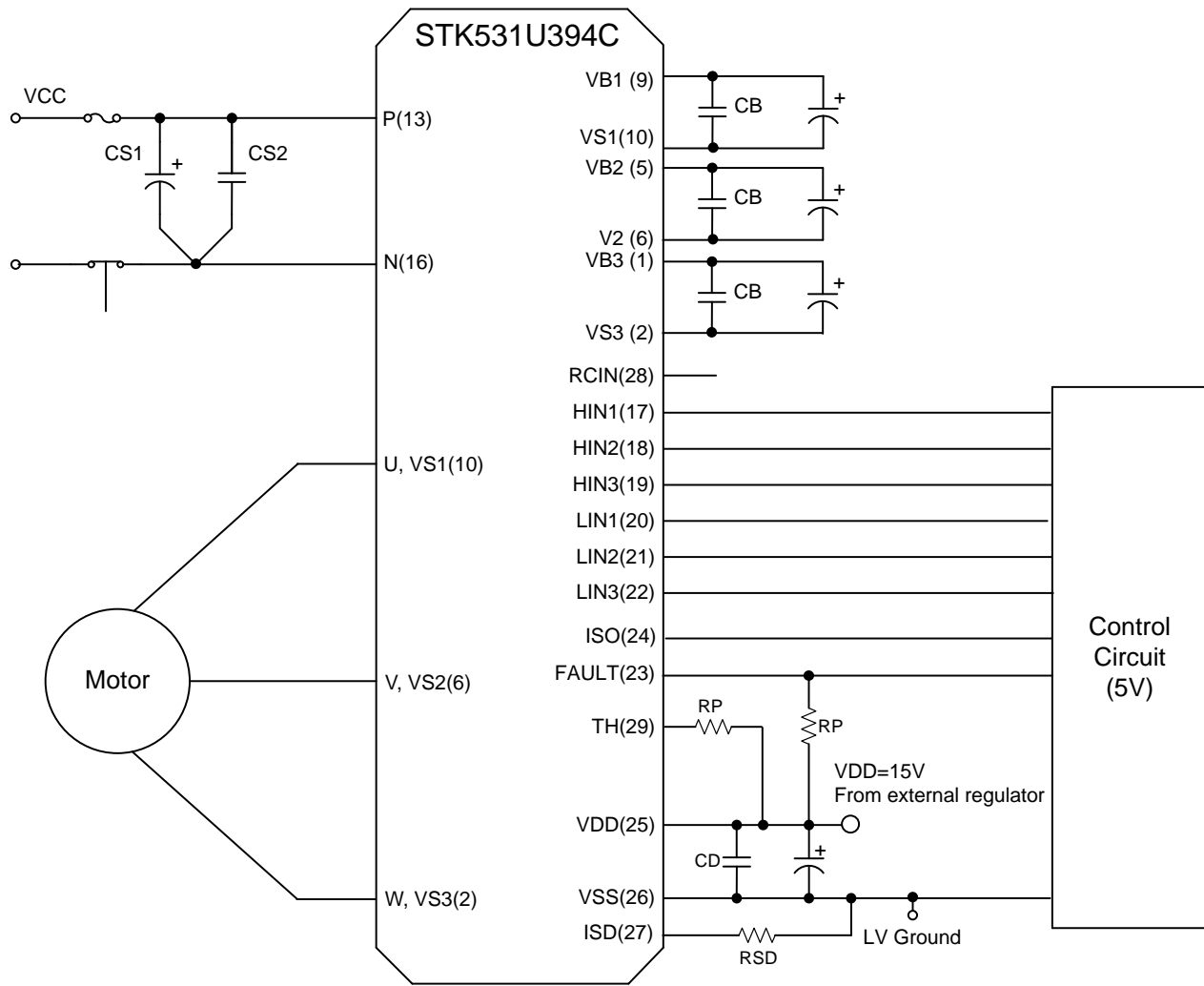

Figure 2. Application Schematic

### Usage Precaution

1. It is essential that wiring length between terminals in the snubber circuit be kept as short as possible to reduce the effect of surge voltages.  
Recommended value of "CS" is in the range of 0.1 to 10  $\mu$ F.
2. "ISO" (pin24) is terminal for current monitor.  
High current may flow into that course when short-circuiting the "ISO" terminal and "VSS" terminal. Please do not connect them.
3. Inside the IPM, a thermistor used as the temperature monitor for internal substrate is connected between VSS terminal and TH terminal therefore, an external pull up resistor connected between the TH terminal and an external power supply should be used.  
The temperature monitor example application is as follows, please refer the Fig.5, and Fig.6 below.

4. Pull down resistor of 33 k $\Omega$  is provided internally at the signal input terminals. An external resistor of 2.2 k to 3.3 k $\Omega$  should be added to reduce the influence of external wiring noise.
5. The level of the over current protection might be changed from IPM design value when "ISD" terminal and "VSS" terminal are shorted at external. Be confirm with actual application ("N" terminal and "VSS" terminal are shorted at internal).
6. The level of the over current protection is adjustable with the external resistor "RSD" between "ISD" terminal and "VSS" terminal.

This data shows the example of the application circuit, does not guarantee a design as the mass production set.

# STK531U394C-E

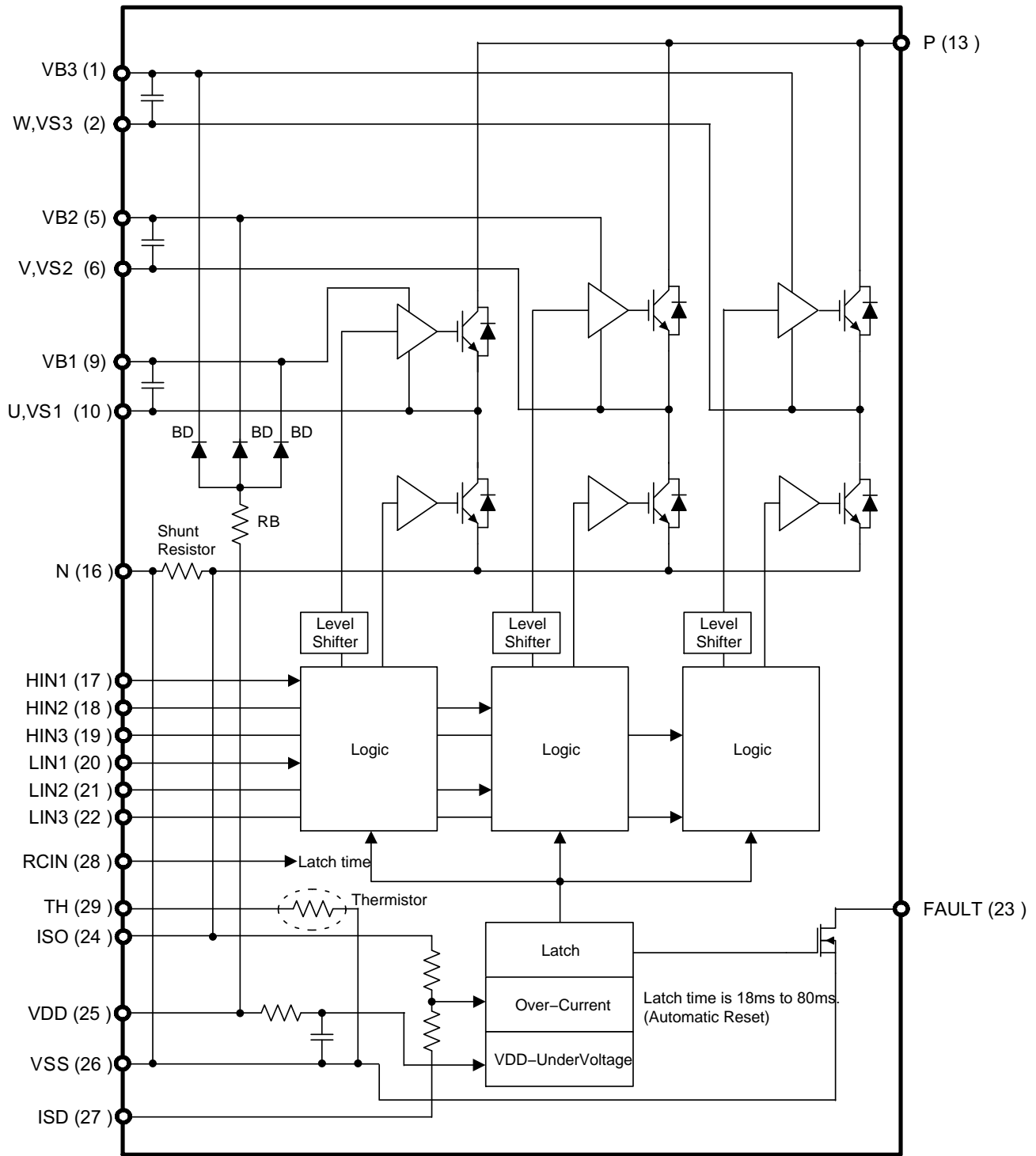

Figure 3. Simplified Block Diagram

Table 1. PIN FUNCTION DESCRIPTION

Pin	Name	Description
1	VB3	High Side Floating Supply Voltage 3
2	W, VS3	Output 3 – High Side Floating Supply Offset Voltage
5	VB2	High Side Floating Supply voltage 2
6	V, VS2	Output 2 – High Side Floating Supply Offset Voltage

# STK531U394C-E

**Table 1. PIN FUNCTION DESCRIPTION** (continued)

Pin	Name	Description
9	VB1	High Side Floating Supply voltage 1
10	U,VS1	Output 1 – High Side Floating Supply Offset Voltage
13	P	Positive Bus Input Voltage
16	N	Negative Bus Input Voltage
17	HIN1	Logic Input High Side Gate Driver – Phase U
18	HIN2	Logic Input High Side Gate Driver – Phase V
19	HIN3	Logic Input High Side Gate Driver – Phase W
20	LIN1	Logic Input Low Side Gate Driver – Phase U
21	LIN2	Logic Input Low Side Gate Driver – Phase V
22	LIN3	Logic Input Low Side Gate Driver – Phase W
23	FAULT	Fault output
24	ISO	Current monitor output
25	VDD	+15V Main Supply
26	VSS	Negative Main Supply
27	ISD	Over current detection and setting
28	RCIN	Fault clear time setting output
29	TH	Thermistor output

NOTE: Pins 3, 4, 7, 8, 11, 12, 14, 15 are not present.

**Table 2. ABSOLUTE MAXIMUM RATINGS** at  $T_C = 25^\circ\text{C}$  (Note 1)

Rating	Symbol	Conditions	Value	Unit
Supply voltage	$V_{CC}$	P to N, surge < 500 V (Note 2)	450	V
Collector–emitter voltage	$V_{CE}$	P to U,V,W or U, V, W, to N	600	V
Output current	$I_o$	P, N, U, V, W terminal current	$\pm 15$	A
		P, N, U, V, W terminal current at $T_c = 100^\circ\text{C}$	$\pm 7$	A
Output peak current	$I_{op}$	P, N, U, V, W terminal current, PW=1ms	$\pm 30$	A
Pre–driver supply voltages	VD1,2,3,4	VB1 to U, VB2 to V, VB3 to W, $V_{DD}$ to $V_{SS}$ (Note 3)	+20	V
Input signal voltage	$V_{IN}$	HIN1, 2, 3, LIN1, 2, 3	-0.3 to $V_{DD}$	V
FAULT terminal voltage	$V_{FAULT}$	FAULT terminal	-0.3 to $V_{DD}$	V
Maximum power dissipation	$P_d$	IGBT per 1 channel	35	W
Junction temperature	$T_j$	IGBT, FRD	150	$^\circ\text{C}$
Storage temperature	$T_{stg}$		-40 to +125	$^\circ\text{C}$
Operating case temperature	$T_c$	IPM case temperature	-20 to +100	$^\circ\text{C}$
Package mounting torque		Case mounting screw	0.9	Nm
Isolation voltage	$V_{is}$	50 Hz sine wave AC 1 minute (Note 4)	2000	Vrms

Stresses exceeding those listed in the Maximum Ratings table may damage the device. If any of these limits are exceeded, device functionality should not be assumed, damage may occur and reliability may be affected.

1. Refer to ELECTRICAL CHARACTERISTICS, RECOMMENDED OPERATING RANGES and/or APPLICATION INFORMATION for Safe Operating parameters
2. This surge voltage developed by the switching operation due to the wiring inductance between P and N terminals.
3. VD1=VB1 to U, VD2 = VB2 to V, VD3 = VB3 to W, VD4 = VDD to VSS terminal voltage.
4. Test conditions: AC 2500 V, 1 s.

# STK531U394C-E

**Table 3. RECOMMENDED OPERATING RANGES** (Note 5)

Rating	Symbol	Conditions	Min	Typ	Max	Unit
Supply voltage	$V_{CC}$	P to N	0	280	450	V
Pre-driver supply voltage	VD1, 2, 3	VB1 to U, VB2 to V, VB3 to W	12.5	15	17.5	V
	VD4	$V_{DD}$ to $V_{SS}$ (Note 5)	13.5	15	16.5	V
PWM frequency	$f_{PWM}$		1	-	20	kHz
Dead time	DT	Turn-off to turn-on (external)	2	-	-	$\mu s$
Allowable input pulse width	PWIN	ON and OFF	1	-	-	$\mu s$
Package mounting torque		'M3' type screw	0.6	-	0.9	Nm

Functional operation above the stresses listed in the Recommended Operating Ranges is not implied. Extended exposure to stresses beyond the Recommended Operating Ranges limits may affect device reliability.

5. Pre-drive power supply (VD4 = 15  $\pm$  1.5 V) must have the capacity of  $I_o = 20$  mA (DC), 0.5 A (Peak).

**Table 4. ELECTRICAL CHARACTERISTICS** at  $T_c = 25^\circ C$ , VD1, VD2, VD3, VD4 = 15 V

Parameter	Test Conditions	Symbol	Min	Typ	Max	Unit	
<b>Power Output Section</b>							
Collector-emitter leakage current	$V_{CE} = 600$ V	$I_{CE}$	-	-	100	$\mu A$	
Bootstrap diode reverse current	$V_{R(BD)} = 600$ V	$I_{R(BD)}$	-	-	100	$\mu A$	
Collector to emitter saturation voltage	$I_c = 15$ A, $T_j = 25^\circ C$	Upper side	$V_{CE(sat)}$	-	1.8	2.3	V
		Lower side (Note 6)		-	2.2	2.7	V
	$I_c = 7$ A, $T_j = 100^\circ C$	Upper side		-	1.5	-	V
		Lower side (Note 6)		-	1.7	-	V
Diode forward voltage	$I_F = 15$ A, $T_j = 25^\circ C$	Upper side	$V_F$	-	2.0	3.2	V
		Lower side (Note 6)		-	2.2	3.4	V
	$I_F = 7$ A, $T_j = 100^\circ C$	Upper side		-	1.6	-	V
		Lower side (Note 6)		-	1.8	-	V
Junction to case thermal resistance	IGBT	$\theta_{j-c(T)}$	-	-	3.8	$^\circ C/W$	
	FRD	$\theta_{j-c(D)}$	-	-	6.0		
Switching time	$I_o = 15$ A, $V_{CC} = 300$ V, $L = 3.9$ mH,	$t_{ON}$	0.3	0.5	1.2	$\mu s$	
		$t_{OFF}$	-	0.6	1.5	$\mu s$	
Turn-on switching loss	$I_o = 7$ A, $V_{CC} = 300$ V, $L = 3.9$ mH	$E_{ON}$	-	160	-	$\mu J$	
Turn-off switching loss		$E_{OFF}$	-	200	-	$\mu J$	
Total switching loss		$E_{TOT}$	-	360	-	$\mu J$	
Turn-on switching loss	$I_o = 7$ A, $V_{CC} = 300$ V, $T_c = 100^\circ C$	$E_{ON}$	-	200	-	$\mu J$	
Turn-off switching loss		$E_{OFF}$	-	250	-	$\mu J$	
Total switching loss		$E_{TOT}$	-	450	-	$\mu J$	
Diode reverse recovery energy	$I_o = 7$ A, $V_{CC} = 400$ V, $T_C = 100^\circ C$ (di/dt set by internal driver)	$E_{REC}$	-	25	-	$\mu J$	
Diode reverse recovery time		$t_{rr}$	-	80	-	ns	
Reverse bias safe operating area	$I_o = 30$ A, $V_{CE} = 450$ V	RBSOA	Full Square				
Short circuit safe operating area	$V_{CE} = 400$ V, $T_c = 100^\circ C$	SCSOA	4	-	-	$\mu s$	
<b>Driver Section</b>							
Pre-driver consumption current	VD1,2,3 = 15 V (Note 3)	$I_D$	-	0.08	0.4	mA	
	VD4 = 15 V		-	1.6	4.0	mA	
High level Input voltage	HIN1, HIN2, HIN3,	$V_{in H}$	2.5	-	-	V	
Low level Input voltage	LIN1, LIN2, LIN3 to VSS	$V_{in L}$	-	-	0.8	V	
Input threshold voltage hysteresis (Note 7)		$V_{inH(hys)}$	0.5	0.8	-	V	

## STK531U394C–E

**Table 4. ELECTRICAL CHARACTERISTICS** at  $T_c = 25^\circ\text{C}$ ,  $V_{D1}, V_{D2}, V_{D3}, V_{D4} = 15\text{ V}$  (continued)

Parameter	Test Conditions	Symbol	Min	Typ	Max	Unit
Logic 1 input current	$V_{IN} = +3.3\text{ V}$	$I_{IN+}$	–	100	143	$\mu\text{A}$
Logic 0 input current	$V_{IN} = 0\text{ V}$	$I_{IN-}$	–	–	2	$\mu\text{A}$
FAULT terminal sink current	FAULT : ON / $V_{FAULT} = 0.1\text{ V}$	$I_{oSD}$	–	2	–	mA
FAULT clearance delay time	Fault output latch time	FLTCLR	18	–	80	ms
VCC and VS undervoltage positive going threshold		$V_{CCUV+}$ $V_{SUV+}$	10.5	11.1	11.7	V
VCC and VS undervoltage negative going threshold		$V_{CCUV-}$ $V_{SUV-}$	10.3	10.9	11.5	V
VCC and VS undervoltage hysteresis		$V_{CCUVH}$ $V_{SUVH-}$	0.14	0.2	–	V
Over current protection level	$PW=100\ \mu\text{s}$ , $RSD = 0\ \Omega$	ISD	22.0	–	27.8	A
Electric current output signal level	$I_o = 15\text{ A}$	ISO	0.36	0.38	0.40	V

Product parametric performance is indicated in the Electrical Characteristics for the listed test conditions, unless otherwise noted. Product performance may not be indicated by the Electrical Characteristics if operated under different conditions.

6. The lower side's  $V_{CE(SAT)}$  and  $V_F$  include a loss by the shunt resistance.

7. Input threshold voltage hysteresis indicates a reference value based on the design value of built-in pre-driver IC.

APPLICATIONS INFORMATION

Input / Output Timing Chart

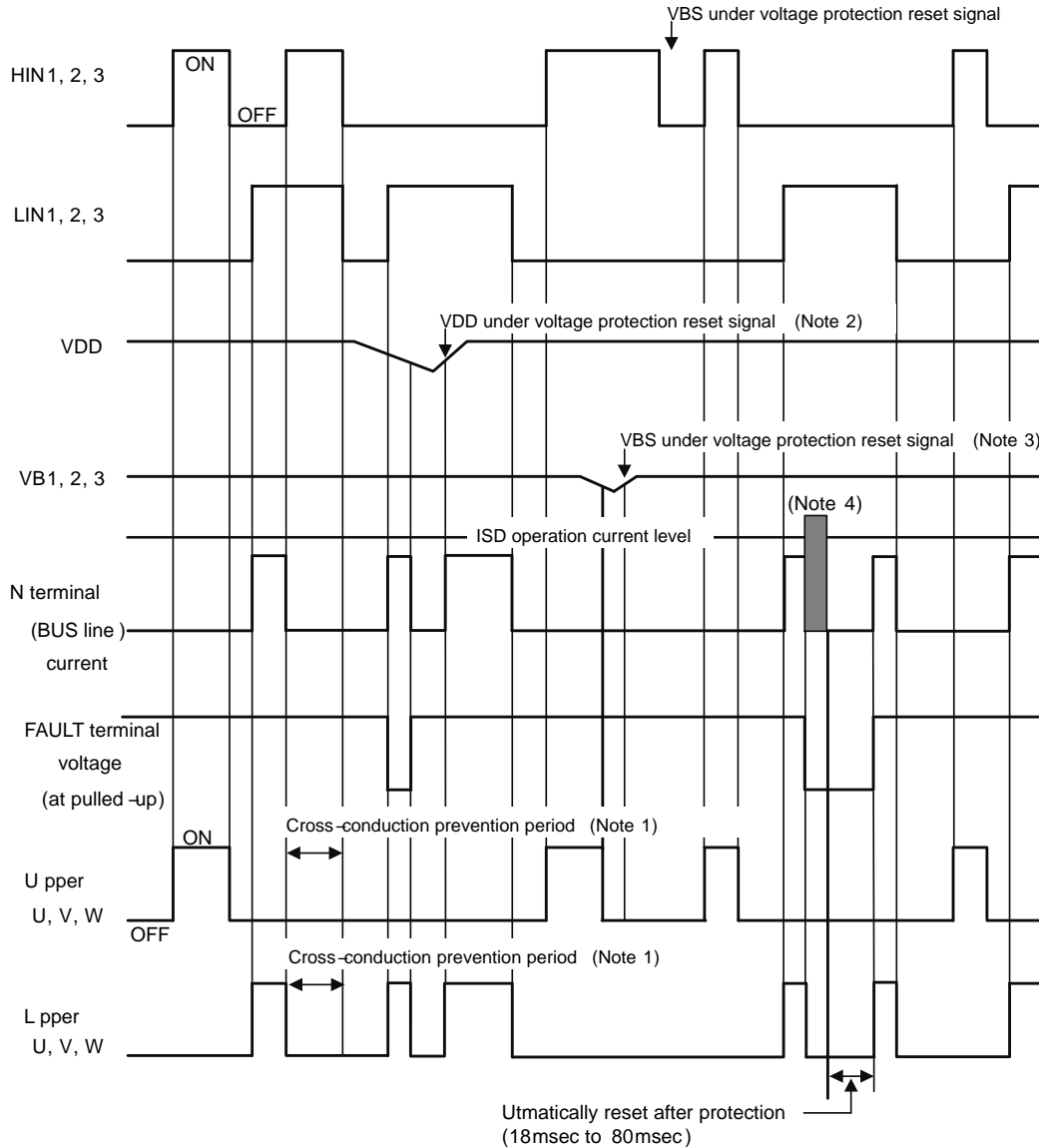

Figure 4. Input / Output Timing Chart

Notes:

1. Diagram shows the prevention of shoot-through via control logic. More dead time to account for switching delay needs to be added externally.
2. When VDD decreases all gate output signals will go low and cut off all of 6 IGBT outputs. When VDD rises the operation will resume immediately.
3. When the upper side gate voltage at VB1, VB2 and VB3 drops only, the corresponding upper side

output is turned off.

The outputs return to normal operation immediately after the upper side gate voltage rises.

4. In case of over current detection, all IGBT's are turned off and the FAULT output is asserted. Normal operation resumes in 18 to 80 ms after the over current condition is removed.

# STK531U394C-E

**Table 5. INPUT / OUTPUT LOGIC TABLE**

INPUT			OUTPUT			
HIN	LIN	OCP	Upper side IGBT	Lower side IGBT	U,V,W	FAULT
H	L	OFF	ON	OFF	P	OFF
L	H	OFF	OFF	ON	N	OFF
L	L	OFF	OFF	OFF	High Impedance	OFF
H	H	OFF	OFF	OFF	High Impedance	OFF
X	X	ON	OFF	OFF	High Impedance	ON

**Table 6. THERMISTOR CHARACTERISTICS**

Parameter	Symbol	Condition	Min	Typ	Max	Unit
Resistance	R <sub>25</sub>	T <sub>c</sub> = 25°C	99	100	101	kΩ
	R <sub>100</sub>	T <sub>c</sub> = 100°C	5.18	5.38	5.60	kΩ
B-Constant (25 to 50°C)	B		4208	4250	4293	K
Temperature Range			-40	-	+125	°C

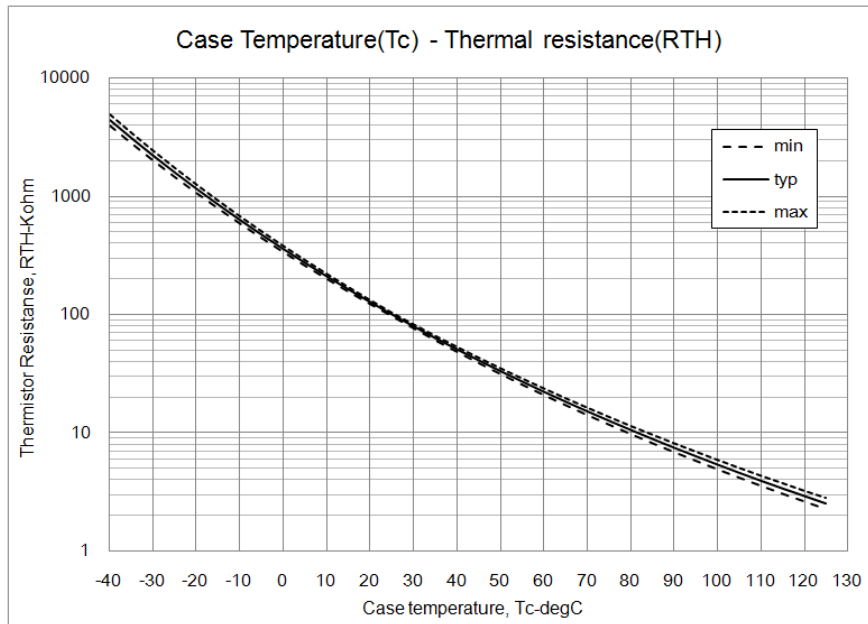

**Figure 5. Thermistor Resistance versus Case Temperature**



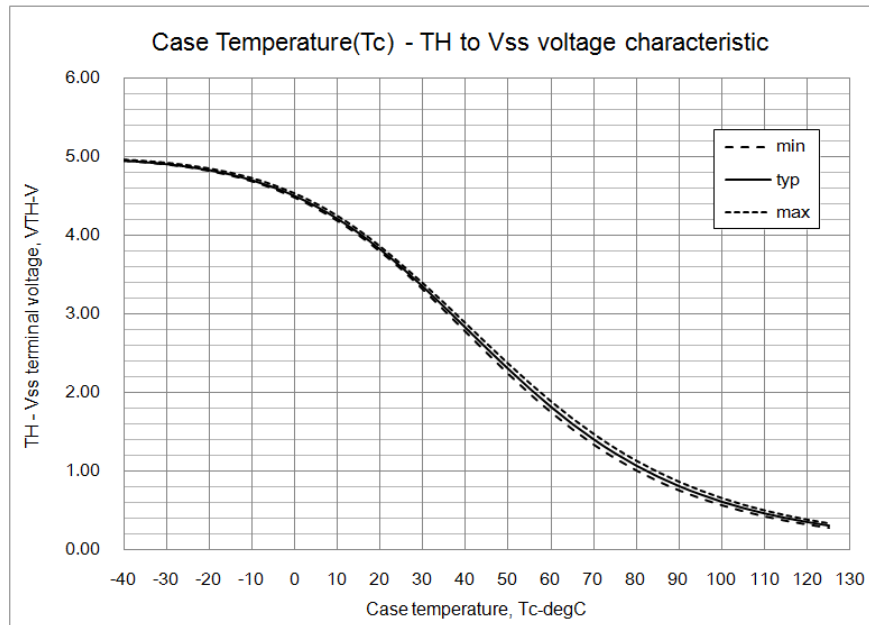

Conditions: R<sub>TH</sub> = 39 kΩ, pull-up voltage 5.0 V

Figure 6. Thermistor Voltage versus Case Temperature

**FAULT Output**

The FAULT terminal is an open drain output requiring a pull-up resistor. If the pull-up voltage is 5 V, use a pull-up resistor with a value of 6.8 kΩ or higher. If the pull-up voltage is 15 V, use a pull-up resistor with a value of 20 kΩ or higher. The FAULT output is triggered if there is a V<sub>DD</sub> undervoltage or an overcurrent condition.

The terminal has a function of enable output, this pin is used to enable or shut down the built-in driver. If the voltage on the FAULT pin rises above the ENABLE ON-state voltage, the output drivers are enabled. If the voltage on the ELTEN pin falls below the ENABLE OFF-state voltage, the drivers are disabled.

**Undervoltage Lockout Protection**

If V<sub>DD</sub> goes below the V<sub>DD</sub> supply undervoltage lockout falling threshold, the FAULT output is switched on. The FAULT output stays on until V<sub>DD</sub> rises above the V<sub>DD</sub> supply undervoltage lockout rising threshold. After V<sub>DD</sub> has risen above the threshold to enable normal operation, the driver waits to receive an input signal on the LIN input before enabling the driver for the HIN signal.

**Overcurrent protection**

The over current protection feature is not intended to protect in exceptional fault condition. An external fuse is recommended for safety.

An additional fuse is recommended to protect against system level or abnormal over-current fault conditions.

**Capacitors on High Voltage and V<sub>DD</sub> Supplies**

Both the high voltage and V<sub>DD</sub> supplies require an electrolytic capacitor and an additional high frequency capacitor.

**Minimum Input Pulse Width**

When input pulse width is less than 1.0 μs, an output may not react to the pulse. (Both ON signal and OFF signal)

**Calculation of Bootstrap Capacitor Value**

The bootstrap capacitor value C<sub>B</sub> is calculated using the following approach. The following parameters influence the choice of bootstrap capacitor:

- VBS: Bootstrap power supply.  
15 V is recommended.
- QG: Total gate charge of IGBT at VBS = 15 V.  
132 nC
- UVLO: Falling threshold for UVLO.  
Specified as 12 V.
- I<sub>D</sub>MAX: High side drive consumption current.  
Specified as 0.4 mA
- t<sub>ON</sub>MAX: Maximum ON pulse width of high side IGBT.

Capacitance calculation formula:

$$C_B = (Q_G + I_{D_{MAX}} * t_{ON_{MAX}}) / (V_{BS} - UVLO)$$

C<sub>B</sub> is recommended to be approximately 3 times the value calculated above. The recommended value of C<sub>B</sub> is in the

range of 1 to 47  $\mu\text{F}$ , however, the value needs to be verified prior to production. When not using the bootstrap circuit, each high side driver power supply requires an external independent power supply.

The internal bootstrap circuit uses a MOSFET. The turn on time of this MOSFET is synchronized with the turn on of the low side IGBT. The bootstrap capacitor is charged by turning on the low side IGBT.

If the low side IGBT is held on for a long period of time (more than one second for example), the bootstrap voltage on the high side MOSFET will slowly discharge.

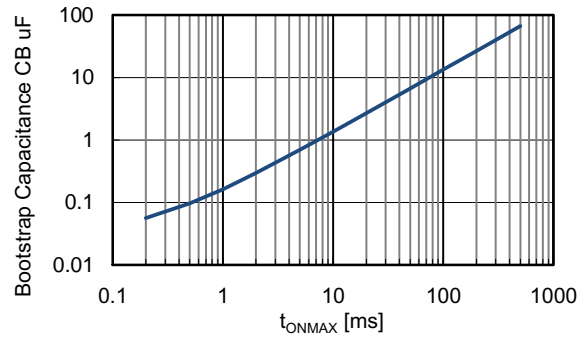

Figure 7. Bootstrap Capacitance versus  $t_{ONMAX}$

Table 7. MOUNTING INSTRUCTIONS

Item	Recommended Condition
Pitch	40.6 $\pm$ 0.1 mm (Please refer to Package Outline Diagram)
Screw	Diameter: M3 Screw head types: pan head, truss head, binding head
Washer	Plane washer The size is D = 7 mm, d = 3.2 mm and t = 0.5 mm JIS B 1256
Heat sink	Material: Aluminum or Copper Warpage (the surface that contacts IPM ): -50 to 100 $\mu\text{m}$ Screw holes must be countersunk. No contamination on the heat sink surface that contacts IPM.
Torque	Temporary tightening: 20 to 30 % of final tightening on first screw Temporary tightening: 20 to 30 % of final tightening on second screw Final tightening: 0.6 to 0.9 Nm on first screw Final tightening: 0.6 to 0.9 Nm on second screw
Grease	Silicone grease. Thickness: 100 to 200 $\mu\text{m}$ Uniformly apply silicone grease to whole back. Thermal foils are only recommended after careful evaluation. Thickness, stiffness and compressibility parameters have a strong influence on performance.

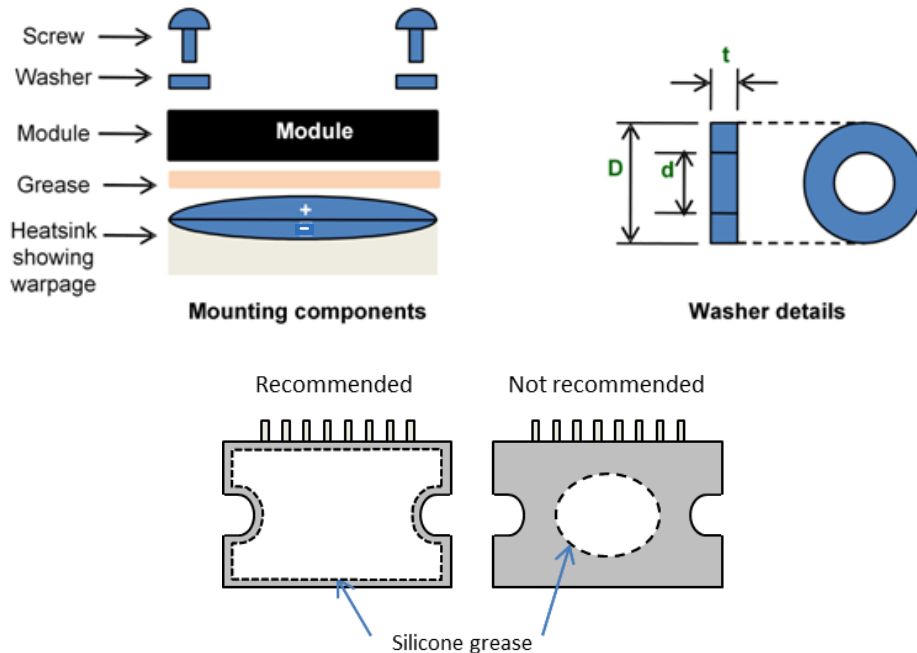

Figure 8. Module Mounting Details: Components; Washer Drawing; Need for Even Spreading of Thermal Grease

# STK531U394C-E

## TEST CIRCUITS

- $I_{CE}$

	U+	V+	W+	U-	V-	W-
M	13	13	13	10	6	2
N	10	6	2	16	16	16

	U(DB)	V(DB)	W(DB)
M	9	5	1
N	26	26	26

NOTE: U+,V+,W+ : High side phase  
U-, V-, W- : Low side phase

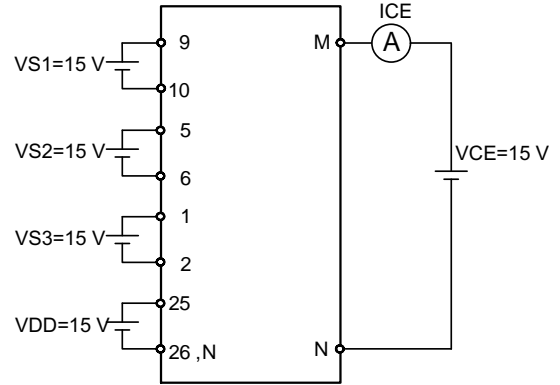

Figure 9. Test Circuit for  $I_{CE}$

- $V_{CE(sat)}$  (Test by pulse)

	U+	V+	W+	U-	V-	W-
M	13	13	13	10	6	2
N	10	6	2	16	16	16
m	17	18	19	20	21	22

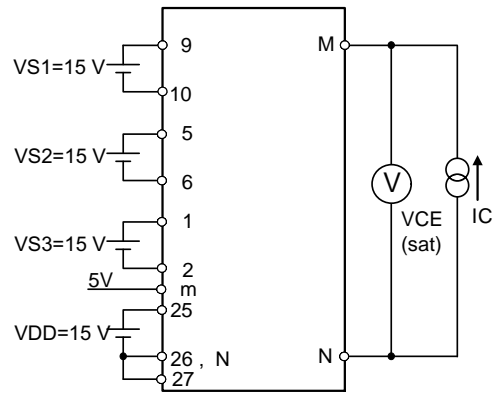

Figure 10. Test Circuit for  $V_{CE(sat)}$

- $V_F$  (Test by pulse)

	U+	V+	W+	U-	V-	W-
M	13	13	13	10	6	2
N	10	6	2	16	16	16

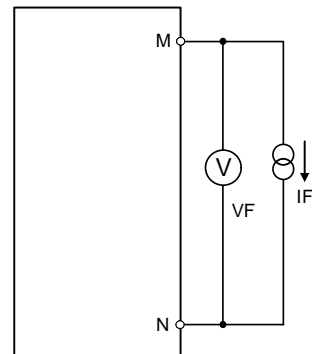

Figure 11. Test Circuit for  $V_F$

# STK531U394C-E

- ID

	VD1	VD2	VD3	VD4
M	9	5	1	25
N	10	6	2	26

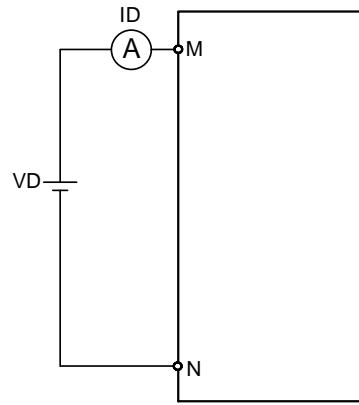

Figure 12. Test Circuit for ID

- ISD

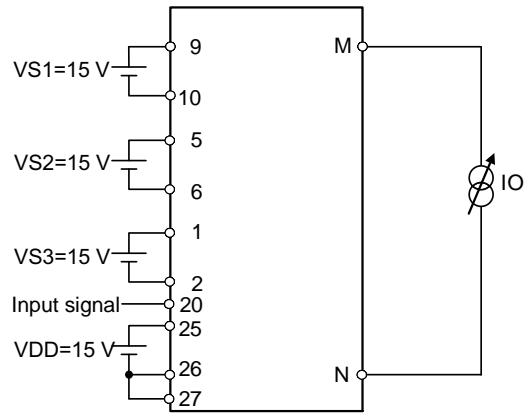
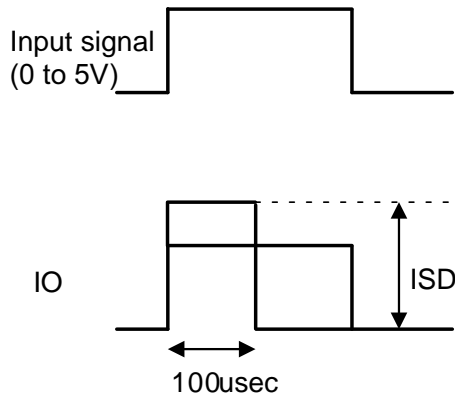

Figure 13. Test Circuit for ISD

- Switching time

(The circuit is a representative example of the low side U phase.)

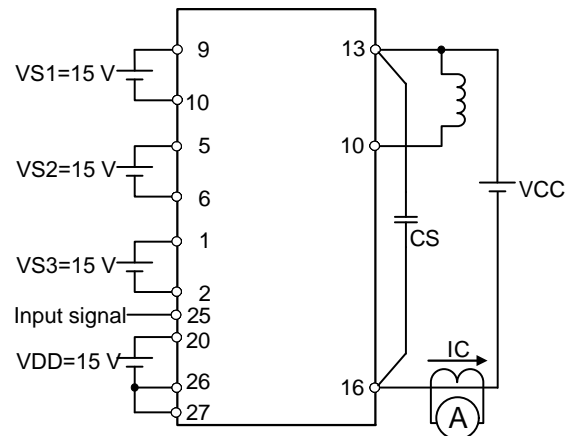
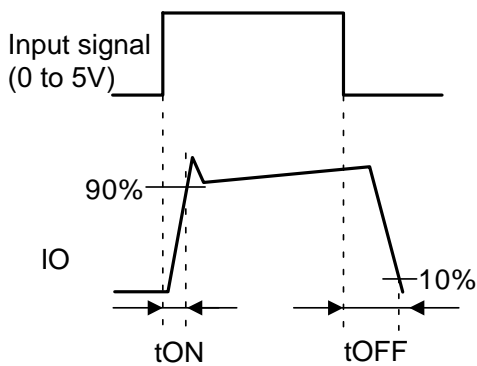

Figure 14. Switching Time Test Circuit

### ORDERING INFORMATION

Device	Marking	Package	Shipping
STK531U394C-E	STK531U394C	SIP29 44x26.5 (Pb-Free)	11 Units / Tube

# MECHANICAL CASE OUTLINE

## PACKAGE DIMENSIONS

ON Semiconductor®



**SIP29 44x26.5**  
**CASE 127ET**  
**ISSUE O**

DATE 18 AUG 2017

**NOTES:**

1. DIMENSIONING AND TOLERANCING PER. ASME Y14.5M, 2009.
2. CONTROLLING DIMENSION: MILLIMETERS
3. DIMENSION b and c APPLY TO THE PLATED LEADS AND ARE MEASURED BETWEEN 1.00 AND 2.00 FROM THE LEAD TIP.
4. POSITION OF THE LEAD IS DETERMINED AT THE ROOT OF THE LEAD WHERE IT EXITS THE PACKAGE BODY.
5. PIN 1 IDENTIFICATION IS A MIRRORED SURFACE INDENT.
6. MISSING PINS ARE 3,4,7,8,11,12,14 AND 15.

DIM	MILLIMETERS		
	MIN.	NOM.	MAX.
A	5.00	5.50	6.00
A1	2.70	3.20	3.70
A2	4.50	5.00	5.50
b	0.55	0.60	0.65
c	0.45	0.50	0.55
D	43.50	44.00	44.50
D1	40.50	41.00	41.50
E	26.00	26.50	27.00
e	1.27 BSC		
F	3.10	3.60	4.10
L	6.30	6.80	7.30
L1	3.80	4.30	4.80

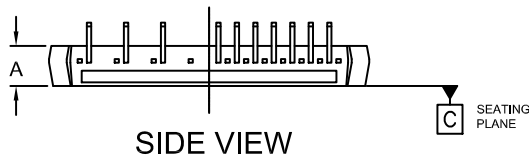
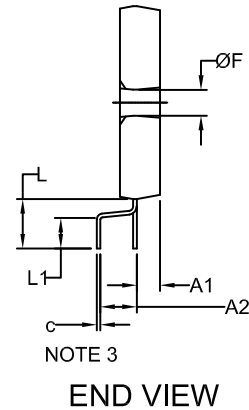
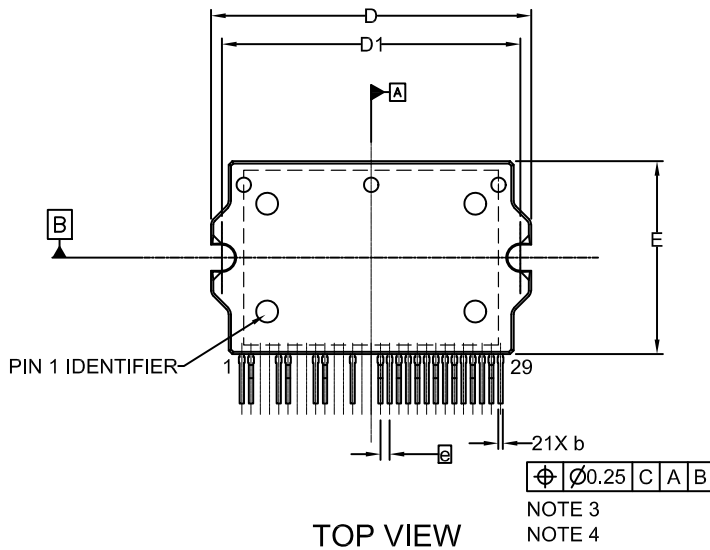

<b>DOCUMENT NUMBER:</b>	<b>98AON73701G</b>	Electronic versions are uncontrolled except when accessed directly from the Document Repository. Printed versions are uncontrolled except when stamped "CONTROLLED COPY" in red.
<b>DESCRIPTION:</b>	<b>SIP29 44X26.5</b>	<b>PAGE 1 OF 1</b>

ON Semiconductor and are trademarks of Semiconductor Components Industries, LLC dba ON Semiconductor or its subsidiaries in the United States and/or other countries. ON Semiconductor reserves the right to make changes without further notice to any products herein. ON Semiconductor makes no warranty, representation or guarantee regarding the suitability of its products for any particular purpose, nor does ON Semiconductor assume any liability arising out of the application or use of any product or circuit, and specifically disclaims any and all liability, including without limitation special, consequential or incidental damages. ON Semiconductor does not convey any license under its patent rights nor the rights of others.

**onsemi**, **Onsemi**, and other names, marks, and brands are registered and/or common law trademarks of Semiconductor Components Industries, LLC dba "**onsemi**" or its affiliates and/or subsidiaries in the United States and/or other countries. **onsemi** owns the rights to a number of patents, trademarks, copyrights, trade secrets, and other intellectual property. A listing of **onsemi**'s product/patent coverage may be accessed at [www.onsemi.com/site/pdf/Patent-Marking.pdf](http://www.onsemi.com/site/pdf/Patent-Marking.pdf). **onsemi** reserves the right to make changes at any time to any products or information herein, without notice. The information herein is provided "as-is" and **onsemi** makes no warranty, representation or guarantee regarding the accuracy of the information, product features, availability, functionality, or suitability of its products for any particular purpose, nor does **onsemi** assume any liability arising out of the application or use of any product or circuit, and specifically disclaims any and all liability, including without limitation special, consequential or incidental damages. Buyer is responsible for its products and applications using **onsemi** products, including compliance with all laws, regulations and safety requirements or standards, regardless of any support or applications information provided by **onsemi**. "Typical" parameters which may be provided in **onsemi** data sheets and/or specifications can and do vary in different applications and actual performance may vary over time. All operating parameters, including "Typicals" must be validated for each customer application by customer's technical experts. **onsemi** does not convey any license under any of its intellectual property rights nor the rights of others. **onsemi** products are not designed, intended, or authorized for use as a critical component in life support systems or any FDA Class 3 medical devices or medical devices with a same or similar classification in a foreign jurisdiction or any devices intended for implantation in the human body. Should Buyer purchase or use **onsemi** products for any such unintended or unauthorized application, Buyer shall indemnify and hold **onsemi** and its officers, employees, subsidiaries, affiliates, and distributors harmless against all claims, costs, damages, and expenses, and reasonable attorney fees arising out of, directly or indirectly, any claim of personal injury or death associated with such unintended or unauthorized use, even if such claim alleges that **onsemi** was negligent regarding the design or manufacture of the part. **onsemi** is an Equal Opportunity/Affirmative Action Employer. This literature is subject to all applicable copyright laws and is not for resale in any manner.

## ADDITIONAL INFORMATION

### TECHNICAL PUBLICATIONS:

Technical Library: [www.onsemi.com/design/resources/technical-documentation](http://www.onsemi.com/design/resources/technical-documentation)  
onsemi Website: [www.onsemi.com](http://www.onsemi.com)

### ONLINE SUPPORT: [www.onsemi.com/support](http://www.onsemi.com/support)

For additional information, please contact your local Sales Representative at [www.onsemi.com/support/sales](http://www.onsemi.com/support/sales)