

**AHPM15-CDA MODULE
CASE MODHG
ISSUE B**

DATE 22 SEP 2021

NOTES:

1. DIMENSIONING AND TOLERANCING PER ASME Y14.5M, 2009.
2. CONTROLLING DIMENSION: MILLIMETERS
3. DIMENSIONS D & E DO NOT INCLUDE MOLD PROTRUSIONS
4. DIMENSIONS b,b1,b2 DO NOT INCLUDE DAMBAR REMAIN.
5. MARKING AREA.

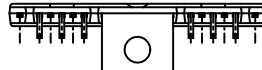

END VIEW

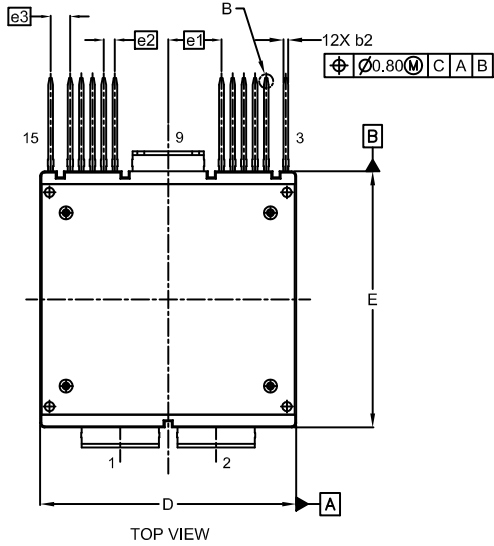

TOP VIEW

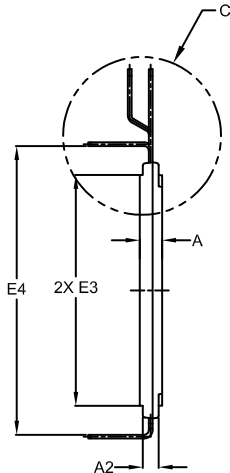

SIDE VIEW

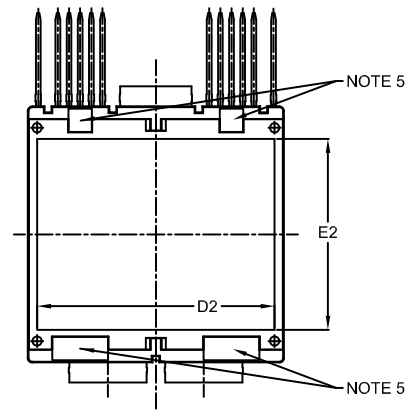

BOTTOM VIEW

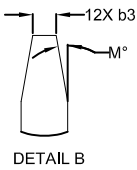

DETAIL B

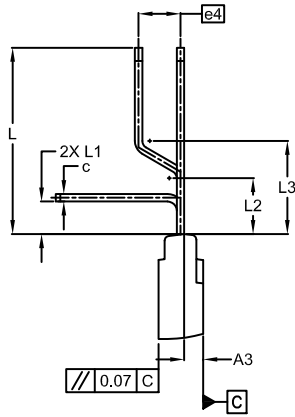

DETAIL C
SCALE N/A

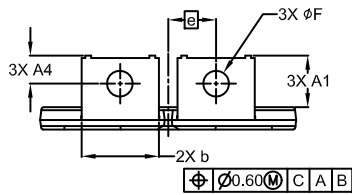

END VIEW

DIM	MILLIMETERS		
	MIN.	NOM.	MAX.
A	4.60	4.80	5.00
A1	10.75	11.05	11.35
A2	3.20	3.40	3.60
A3	1.70	2.05	2.40
A4	5.70	6.00	6.30
b	16.50	16.60	16.70
b1	15.20	15.30	15.40
b2	0.90	1.00	1.10
b3	0.50 REF		
c	0.70	0.80	0.90
D	54.80	55.00	55.20
D2	50.40	51.00	51.60

DIM	MILLIMETERS		
	MIN.	NOM.	MAX.
E	54.80	55.00	55.20
E2	40.40	41.00	41.60
E3	49.40	49.60	49.80
E4	61.50	62.00	62.50
e	10.00	10.30	10.60
e1	11.15	11.45	11.75
e2	2.40 BSC		
e3	4.20 BSC		
e4	4.20	4.50	4.80
F	5.40	5.50	5.60
L	19.60	20.00	20.40
L1	3.10	3.50	3.90
L2	6.00 REF		
L3	10.00 REF		
M	10° REF		

DOCUMENT NUMBER:	98AON23821H	Electronic versions are uncontrolled except when accessed directly from the Document Repository. Printed versions are uncontrolled except when stamped "CONTROLLED COPY" in red.
DESCRIPTION:	AHPM15-CDA MODULE	PAGE 1 OF 2

onsemi and ONSEMI are trademarks of Semiconductor Components Industries, LLC dba onsemi or its subsidiaries in the United States and/or other countries. onsemi reserves the right to make changes without further notice to any products herein. onsemi makes no warranty, representation or guarantee regarding the suitability of its products for any particular purpose, nor does onsemi assume any liability arising out of the application or use of any product or circuit, and specifically disclaims any and all liability, including without limitation special, consequential or incidental damages. onsemi does not convey any license under its patent rights nor the rights of others.

**AHPM15-CDA MODULE
CASE MODHG
ISSUE A**

DATE 22 SEP 2021

**GENERIC
MARKING DIAGRAM***

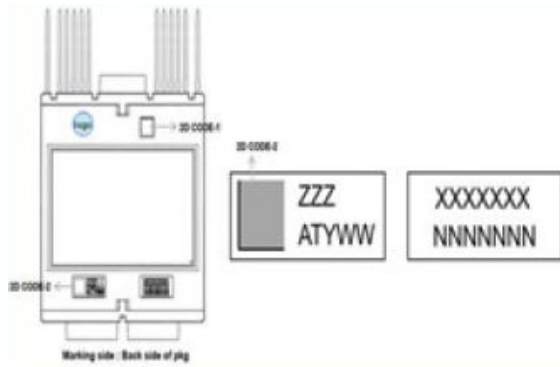

ZZZ = Assembly Lot Code
 AT = Assembly & Test Location
 Y = Year
 WW = Work Week
 NNNN = Serial Number

*This information is generic. Please refer to device data sheet for actual part marking. Pb-Free indicator, "G" or microdot "▪", may or may not be present. Some products may not follow the Generic Marking.

DOCUMENT NUMBER:	98AON23821H	Electronic versions are uncontrolled except when accessed directly from the Document Repository. Printed versions are uncontrolled except when stamped "CONTROLLED COPY" in red.
DESCRIPTION:	AHPM15-CDA MODULE	PAGE 2 OF 2

onsemi and **ONSEMI** are trademarks of Semiconductor Components Industries, LLC dba **onsemi** or its subsidiaries in the United States and/or other countries. **onsemi** reserves the right to make changes without further notice to any products herein. **onsemi** makes no warranty, representation or guarantee regarding the suitability of its products for any particular purpose, nor does **onsemi** assume any liability arising out of the application or use of any product or circuit, and specifically disclaims any and all liability, including without limitation special, consequential or incidental damages. **onsemi** does not convey any license under its patent rights nor the rights of others.