

产品概览

LC709511F: 移动电源控制器、USB Type-C和快充TM 3.0 , 应用于单节锂离子电池和锂聚合物电池

欲看完整文档, 请参阅数据表。

LC709511F is a Lithium ion switching charger controller for Power Bank. This device has all functions to control Power Bank application. It includes Type-C port control and Quick Charge 3.0 HVDCP. In addition this device applies 2.0 V or 2.7 V on USB data lines automatically for devices require the voltage. The built-in switching controller can output from 5 V up to 12 V for Quick Charge. The high power output for USB Type-C and Quick Charge is possible with appropriate external MOSFETs.

特性

- Easy power scaling with external MOSFETs
- Buck charge / Boost charge
- Supports Quick Charge 3.0 HVDCP Class A. 5 V up to 12 V
- Supports USB type-C DRP without external IC
- Applies 2.7 V or 2.0 V on USB data lines for devices require it
- Prepared firmware supports various combination of USB port
- Supports USB BC1.2
- Battery level gauging
- Status & Battery level display with 4 LEDs
- Boost auto start-up

For more features, see the data sheet

优势

- Power scaling with external MOSFETs support 30 W application
- Basic functions required in Power Bank Application is prepared
- HV Boost IC and QC communication IC can be eliminated. It reduces the set cost.
- Built-in portcontrol IC
- Recognize types of PortableDevice and require the most suitable current
- It can change firmware depend on customer models.
- Supports general adapters
- Simple setting for various batteries
- Built-in 4 LED drivers, customers don't need add MCU
- Customer don't need to add button to charge smartphone.

应用

- Lithium-ion Switching Charger Controller
- USB-related Charger

终端产品

- Power Bank

器件电气规格

产品	Pricing (\$/Unit)	Compliance	Status	Type	Number of Cells Charged	V _{CC} Min (V)	V _{CC} Max (V)	I _D Max (μA)	Package Type
LC709511FQD-A00TWG	3.4132	Pb-free Halide free	Active	Li-Ion/Polymer	1	2.8	13.2	15	QFN-52

应用框图

Power Bank Application (Reference Software : FW02)

Micro-B (Sink : BC1.2) + Type-A (1) (Source : Quick Charge 3.0 HVDCP) + Type-A (2) (Source : DCP and Divided mode)

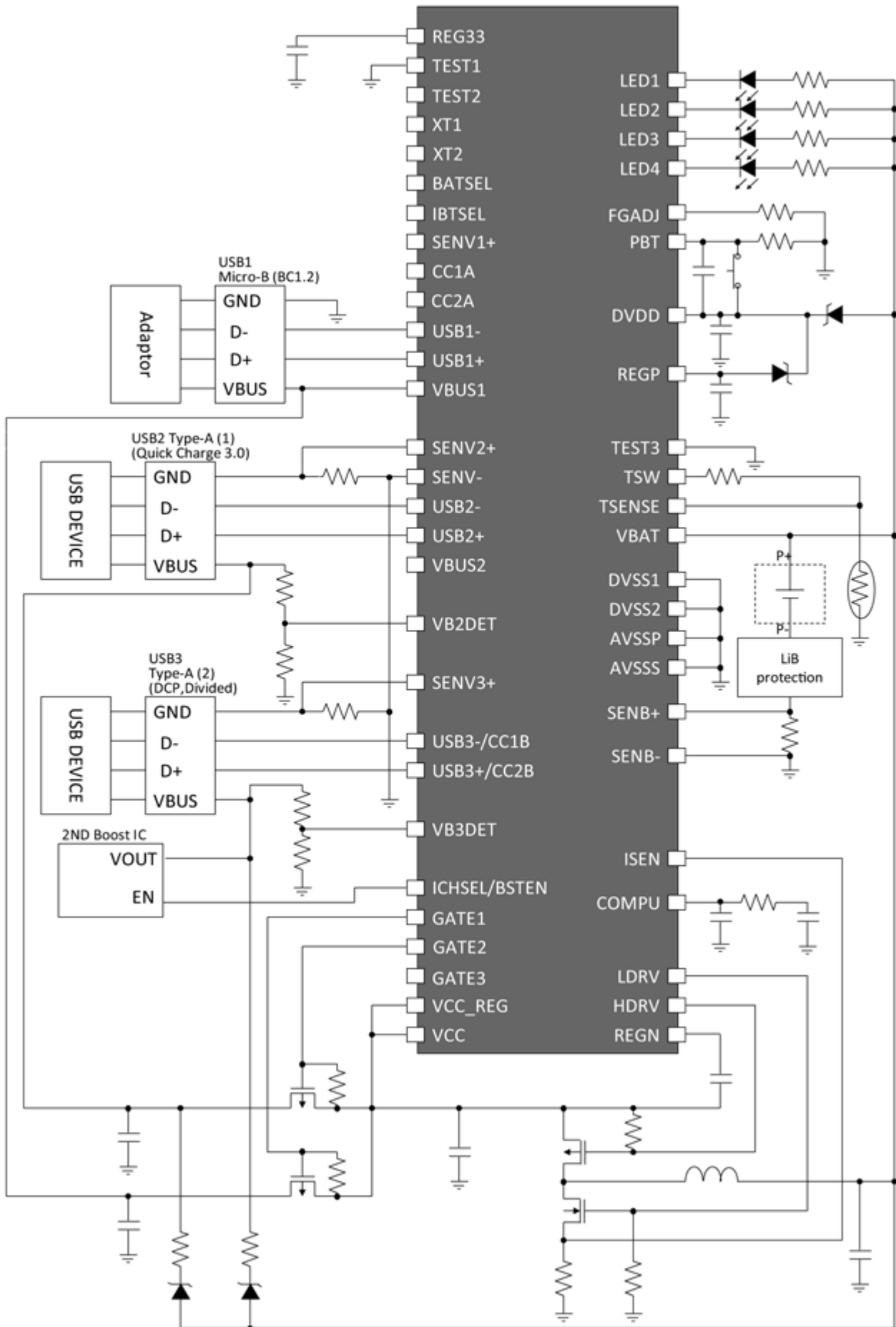

Power Bank Application (Reference Software : FW05)

Type-C (Sink : BC1.2, Source : Quick Charge 3.0 HVDCP) + Type-A (Source : DCP and Divided mode)

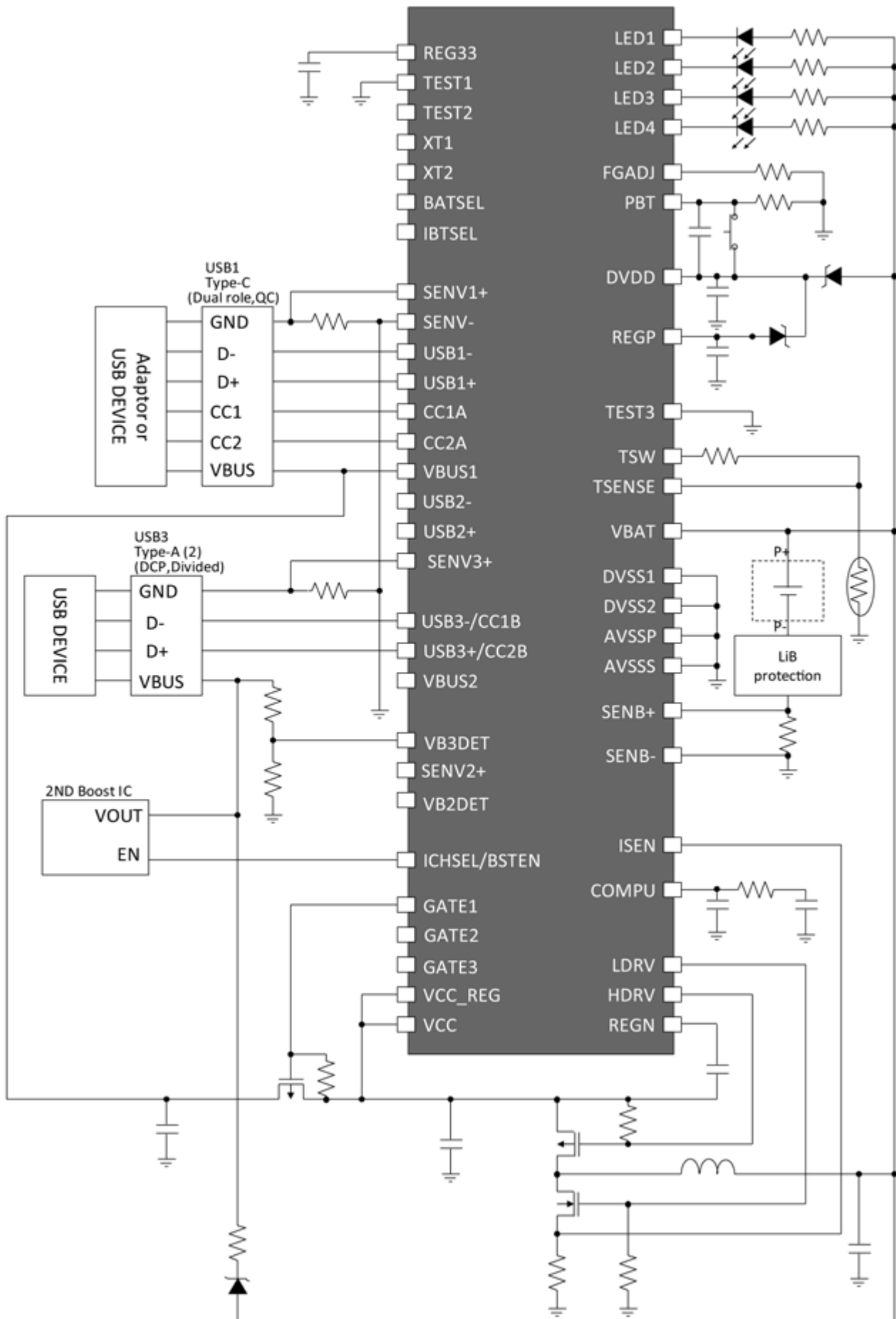

创建于：4/4/2020