

ON Semiconductor

Is Now

onsemi™

To learn more about onsemi™, please visit our website at
www.onsemi.com

onsemi and **onsemi** and other names, marks, and brands are registered and/or common law trademarks of Semiconductor Components Industries, LLC dba "**onsemi**" or its affiliates and/or subsidiaries in the United States and/or other countries. **onsemi** owns the rights to a number of patents, trademarks, copyrights, trade secrets, and other intellectual property. A listing of **onsemi** product/patent coverage may be accessed at www.onsemi.com/site/pdf/Patent-Marking.pdf. **onsemi** reserves the right to make changes at any time to any products or information herein, without notice. The information herein is provided "as-is" and **onsemi** makes no warranty, representation or guarantee regarding the accuracy of the information, product features, availability, functionality, or suitability of its products for any particular purpose, nor does **onsemi** assume any liability arising out of the application or use of any product or circuit, and specifically disclaims any and all liability, including without limitation special, consequential or incidental damages. Buyer is responsible for its products and applications using **onsemi** products, including compliance with all laws, regulations and safety requirements or standards, regardless of any support or applications information provided by **onsemi**. "Typical" parameters which may be provided in **onsemi** data sheets and/or specifications can and do vary in different applications and actual performance may vary over time. All operating parameters, including "Typicals" must be validated for each customer application by customer's technical experts. **onsemi** does not convey any license under any of its intellectual property rights nor the rights of others. **onsemi** products are not designed, intended, or authorized for use as a critical component in life support systems or any FDA Class 3 medical devices or medical devices with a same or similar classification in a foreign jurisdiction or any devices intended for implantation in the human body. Should Buyer purchase or use **onsemi** products for any such unintended or unauthorized application, Buyer shall indemnify and hold **onsemi** and its officers, employees, subsidiaries, affiliates, and distributors harmless against all claims, costs, damages, and expenses, and reasonable attorney fees arising out of, directly or indirectly, any claim of personal injury or death associated with such unintended or unauthorized use, even if such claim alleges that **onsemi** was negligent regarding the design or manufacture of the part. **onsemi** is an Equal Opportunity/Affirmative Action Employer. This literature is subject to all applicable copyright laws and is not for resale in any manner. Other names and brands may be claimed as the property of others.

Constant Current Regulator Charging Circuit

Abstract

This application note describes how a Constant Current Regulator, CCR, can be used in a low cost charging circuit for rechargeable batteries, providing a simple controller to terminate charging.

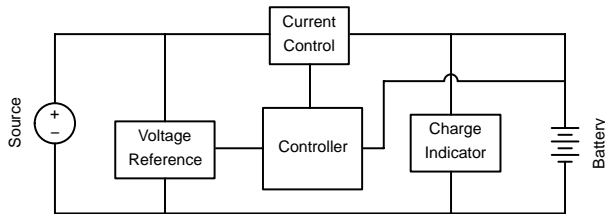

Figure 1. Block Diagram of Charging Circuit

Types of Rechargeable Batteries

The three most common rechargeable batteries are Nickel Metal Hydride (NiMH), Nickel Cadmium (NiCad), and Lithium Ion (Li-Ion). When referring to the rate at which a battery is charged the letter “C” is used. The “C” defines the capacity of the battery over 1.0 hour. For example, a battery rated at 800 mAh could be charged at 0.5C resulting in a charge current of 400 mA over two hours to fully charge the battery.

Nickel Metal Hydride and Nickel Cadmium

The nominal voltage of a NiMH battery is 1.2 V/cell and should be charged up to 1.5–1.6 V/cell. There are several different techniques for determining when to shutoff the charge. They include: peak voltage detection, negative delta voltage, delta temperature (dT/dt), temperature threshold, and timers. For high end chargers these may be all combined into one charger.

The CCR charger is a peak voltage detect circuit and terminates charging at a predetermined peak. The predetermined peak voltage is 1.5 V/cell, and will charge the battery to ≈ 97%.

Nickel Cadmium batteries can be charged using this circuit. They perform very similar to NiMH batteries so this method will work well for them.

Lithium Ion

The usual method of charging a Li-Ion battery is to charge the battery to 4.2 V/cell at 0.5C to 1C followed by a trickle charge. The temperature rise of Li-Ion batteries should be kept below 5°C while charging, a higher temperature rise indicates a potential to combust. The trickle charge portion of the charge cycle is when the battery temperature rises the most and it has the greatest chance to combust. High end chargers use smart IC’s, such as the NCP1835B, to monitor and control the charge of Lithium ion batteries because of this issue.



ON Semiconductor®

www.onsemi.com

APPLICATION NOTE

The CCR controller discussed here eliminates this by not including a trickle charge, keeping the battery in a safe operating area and helping to increase the life of the battery. However, by eliminating the trickle charge the battery will only receive ≈ 85% charge.

Setting the Reference Voltage

The TL431, a three-terminal programmable shunt regulator, is used to set the reference voltage. It is designed to give a constant 2.5 V output at its reference pin. When two external resistors are connected as shown in Figure 2, the reference voltage can be selected from 2.5 V to 36 V. For our purposes we will set R₂ to 1.0 kΩ, and will adjust R_{ref} to match the reference voltage we want. The equation used to find the ratio of R₂/R_{ref} is given by:

$$V_{\text{ref}} = \left(1 + \frac{R_2}{R_{\text{ref}}} \right) 2.5$$

The resistor that is connected to the cathode of the TL431 is used to limit the current, and to separate the input voltage from the reference voltage.

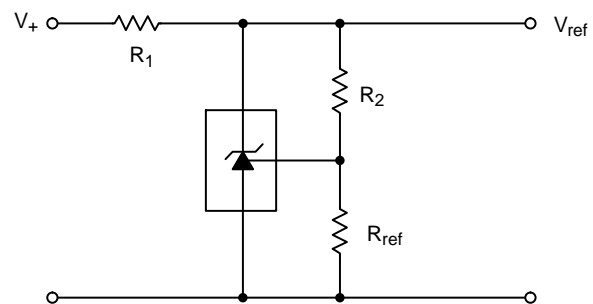

Figure 2. Setup of Reference Voltage

Comparator with Hysteresis Loop

The LM311, a Single comparator, is used to compare the voltage of the battery to the reference voltage. Connected to the inverting input is the battery voltage. Hysteresis is provided by a feedback resistor (R_h) between the output and the non-inverting input. R₃, a 1.0 kΩ resistor is used to make the ratio of R₃/R_h simple. By adjusting R_h you can change the bandwidth of the hysteresis loop. By increasing R_h you

AND9031/D

decrease the bandwidth and vice versa. It is recommended the bandwidth of the hysteresis be greater than 200 mV because when charging is terminated the voltage of the battery will drop slightly. The equations to calculate the high and low voltages of the inverting input are:

$$V_{inL} = \frac{R_3}{R_3 + R_h}(V_{OL} - V_{ref}) + V_{ref}$$

$$V_{inH} = \frac{R_3}{R_3 + R_h}(V_{OH} - V_{ref}) + V_{ref}$$

A 1.0 kΩ resistor (R_4) is connected to the output of the comparator to act as a pull-up resistor.

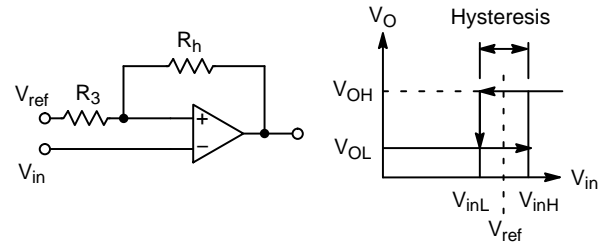

Figure 3. Hysteresis Setup

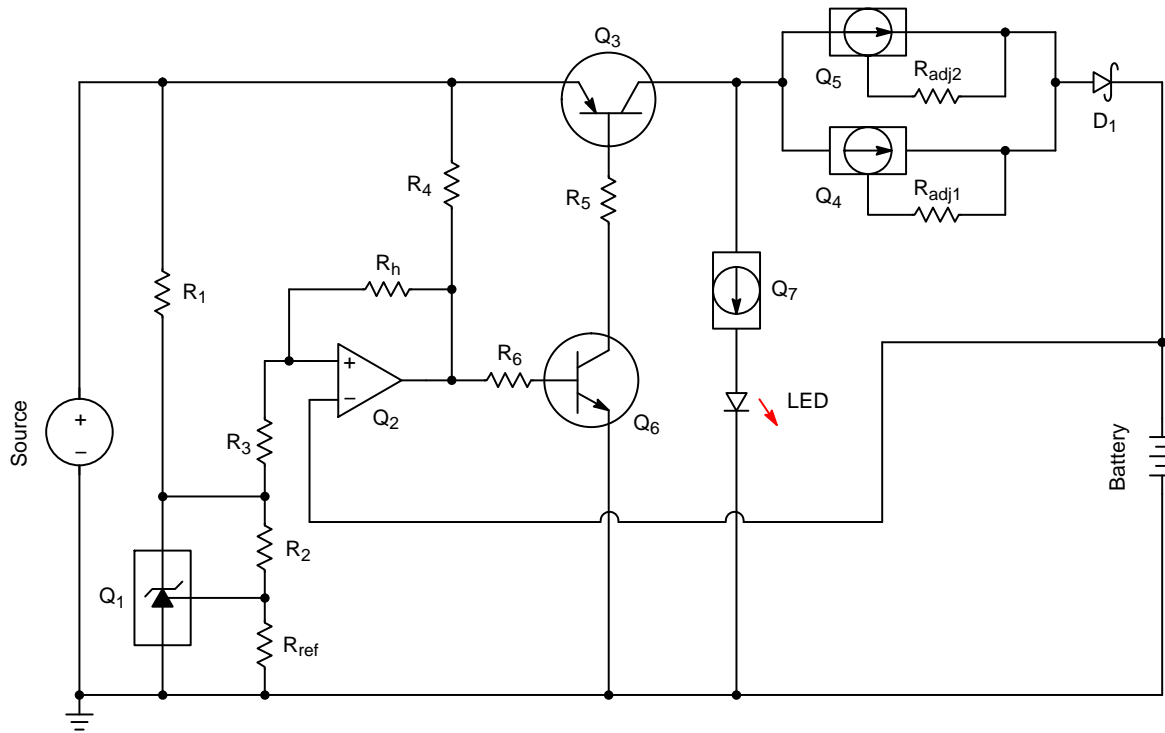

Figure 4. Schematic of Charging Circuit

Current Switch

The two BJTs (Q_3 and Q_6) in the circuit are acting as the switch to control the charging current. The base of Q_6 is controlled by the output of the comparator through a 5.6 kΩ resistor (R_6). The collector of Q_6 is connected to the base of Q_3 through a 1.0 kΩ resistor (R_5). When the output of the comparator goes Low, Q_6 is turned off, causing Q_3 to turn off which terminates the charge current.

Current Regulation

The charging current for the batteries is controlled by using a CCR. The current can be adjusted by using an adjustable CCR and/or putting CCR's in parallel. This demo board is designed for two CCRs in parallel, Q_4 and Q_5 . (It is possible to connect more than two CCR's in parallel so any current that you desire can be reached). For the experiments discussed in this application note the CCR

(NSI45090JDT4G) could be adjusted from 90 mA – 160 mA. The three currents used for data analysis were, 90, 180, and 300 mA.

Indicator LED

To indicate that the battery is being charged a LED with a CCR, Q_7 , is used. A CCR supplies the LED with a constant current. The LED will also be “On” when there is no battery connected to the charger. When the LED turns “Off” this indicates that the battery has been fully charged.

Setup for the Different test Currents

Table 1 shows the values to the variable components that determine the charge current and at what voltage the charge is terminated. While testing at 180 mA two NSI45090JDT4G CCRs were used to give an output current of 90 mA with $R_{adj} = 10 \Omega$.

Table 1. RESISTANCE VALUES FOR TESTS

Battery Type/ Charge Current	R _{ref}	R _h	R _{adj1}	R _{adj2}
Li-Ion/90 mA	1.8 kΩ	18 kΩ	∞	*
Li-Ion/180 mA	1.8 kΩ	18 kΩ	∞	∞
Li-Ion/300 mA	1.8 kΩ	18 kΩ	5.0 Ω	5.0 Ω
NiMH/90 mA	1.4 kΩ	18 kΩ	∞	*
NiMH/180 mA	1.4 kΩ	18 kΩ	∞	∞
NiMH/300 mA	1.4 kΩ	18 kΩ	5.0 Ω	5.0 Ω

*Q5 is not used, no need for R_{adj2}

Results

The CCR charging circuit was tested by charging both Li-ion and NiMH batteries at 90 mA, 180 mA, and 300 mA. Table 2 shows key voltages that were monitored while a battery was being charged. While Table 3 shows the same key voltages just after the circuit terminates the charging of the battery.

In Table 3 the data for the NiMH being charged at 90 mA is excluded. During this test the temperature of the battery started to climb rapidly (see Table 4), the test was ended before the battery voltage reached the reference voltage. This high temperature rise of the NiMH batteries when being charged at low currents is discussed on the TECHNIK website www.technik.net.

Table 2. VOLTAGES WHILE CHARGING

Battery Type/ Charge Current	Comparator Output Voltage (V)	PNP Collector Voltage (V)	PNP Emitter Voltage (V)	PNP Collector – Emitter Voltage (V)	PNP Base Voltage (V)	Diode Forward Voltage (V)
Li-Ion/90 mA	10.13	12.123	12.141	0.018	8.776	0.2914
Li-Ion/180 mA	10.124	12.102	12.134	0.032	8.785	0.3109
Li-Ion/300 mA	10.08	12.029	12.08	0.051	8.745	0.3247
NiMH/90 mA	10.155	12.132	12.151	0.019	8.782	0.2918
NiMH/180 mA	10.142	12.103	12.135	0.032	8.787	0.3107
NiMH/300 mA	10.109	12.045	120.94	0.049	8.746	0.3263

Table 3. VOLTAGES JUST AFTER CHARGING WAS TERMINATED

Battery Type/Charge Current	Comparator Output Voltage (V)	PNP Collector Voltage (V)	PNP Emitter Voltage (V)	PNP Collector – Emitter Voltage (V)	Diode Forward Voltage (V)
Li-Ion/90 mA	0.223	1.381	12.167	10.786	-2.764
Li-Ion/180 mA	0.223	1.3	12.165	10.865	-2.378
Li-Ion/300 mA	0.223	1.383	12.16	10.777	-2.679
NiMH/180 mA	0.223	1.37	12.165	10.795	-3.025
NiMH/300 mA	0.223	1.35	12.16	10.81	-2.936

Table 4 contains temperature data for the batteries. In all cases the ambient temperature was approximately 25°C. For Li-ion batteries it can be concluded that the higher the charge current the more the temperature of the battery will rise. The

same can be said for NiMH batteries when charging above 0.1C. It is important to keep this in mind when selecting what charge rate will be used.

Table 4. TEMPERATURES OF THE BATTERIES

Battery Type/Charge Current	Start Battery Temperature (°C)	Maximum Battery Temperature (°C)	Change in Battery Temperature (°C)
Li-Ion/90 mA	25.0	26.0	1.0
Li-Ion/180 mA	25.0	27.7	2.7
Li-Ion/300 mA	25.0	28.4	3.4
NiMH/90 mA	25.0	30.0	5.0
NiMH/180 mA	25.0	27.9	2.9
NiMH/300 mA	25.0	28.1	3.1

Charge Current Over Time

With the use of the Constant Current Regulator the charge current is held constant until the charging is terminated as seen in Figure 5.

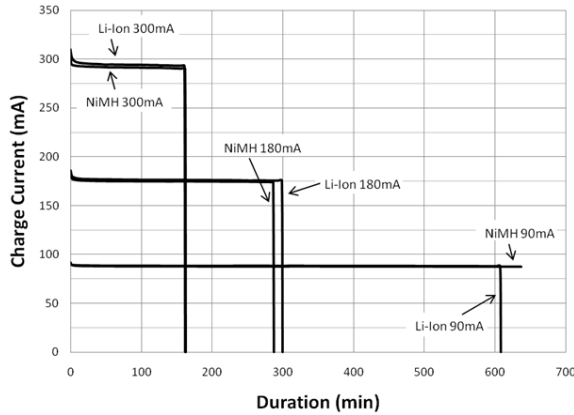

Figure 5. Charge Current vs. Time

Power Dissipation of BJT and Diode

In today's circuits people are very concerned about power dissipation. Lowering the input voltage is one way to increase the performance of the circuit. This is one reason why a low $V_{CE(sat)}$ transistor was used. As shown in Table 1 the V_{CE} of the transistor is very low. This is also reinforced with Figure 6 which depicts the power dissipated by the PNP transistor over time. As one would expect as the charge current is increased the PD increases. However at a charge current of approximately 300 mA the power dissipated over the transistor is less than 15 mW.

In addition to using a low $V_{CE(sat)}$ BJT a DSN2 low V_F Schottky barrier diode was used to minimize the power dissipated. The diode is used for reverse current protection. The NSR10F40NXT5G was used because it has one of the lowest V_F 's the market has to offer. At the highest charging current tested the power dissipated by the diode is around 95 mW. Figure 7 shows the power dissipation of the DSN2 Low V_F Schottky barrier diode as the battery is being charged.

With using both a Low $V_{CE(sat)}$ BJT and Low V_F Schottky diode the input voltage is the lowest possible.

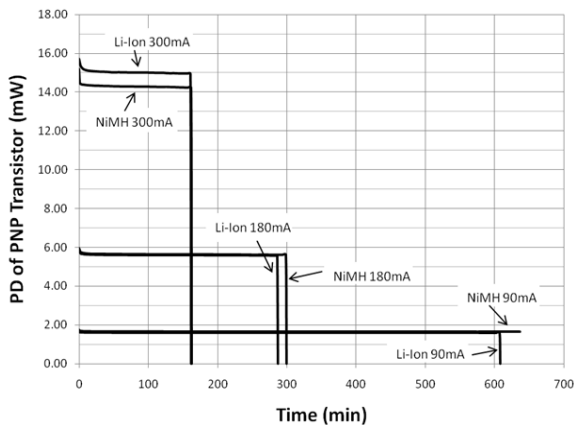

Figure 6. PD of PNP Transistor vs. Time

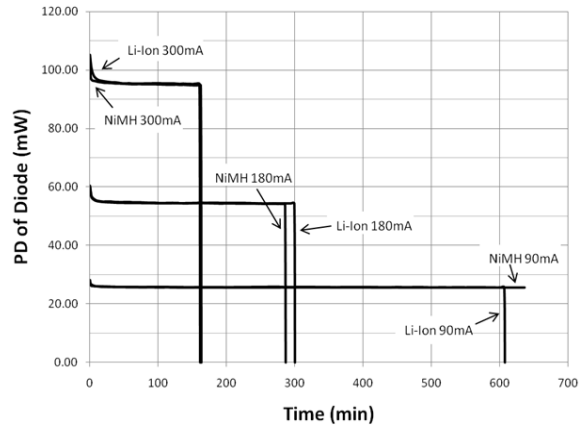

Figure 7. PD of Diode vs. Time

Power Dissipation of CCR

Power dissipation is a very important parameter when using a CCR. This is the device where all the voltage will be dropped to ensure that the battery is charged at a constant current. As the device begins to heat up the current begins to drop. To minimize the temperature rise of the CCR copper is placed on most of the empty space of the board. The cathode of the CCR is then connected to this area of copper to act as a heat sink. When using multiple CCR's in parallel keep in mind that the power dissipated by the individual CCR is only the voltage multiplied by the individual current that is going through the CCR. Not the total charge current. Figure 8 shows the power dissipated by the CCRs over time. Only one of the CCRs data is shown when multiple CCRs are used to obtain higher charge currents.

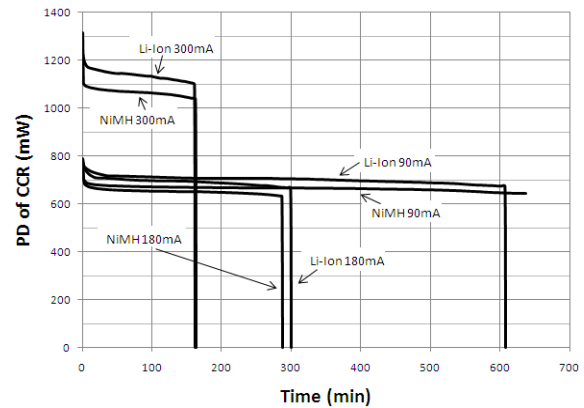

Figure 8. PD of CCR vs. Time

Battery Voltage over Time

Figure 9 depicts the voltage of the battery for all six test cases. For the Li-Ion battery voltages one would expect to see them start to flatten off as the voltage reaches 4.2 V. In more advanced circuits this would be when a trickle charge would be applied. However, as discussed in the Types of Rechargeable Batteries section this circuit is designed to stop charging at predefined voltage, in this case 4.15 V.

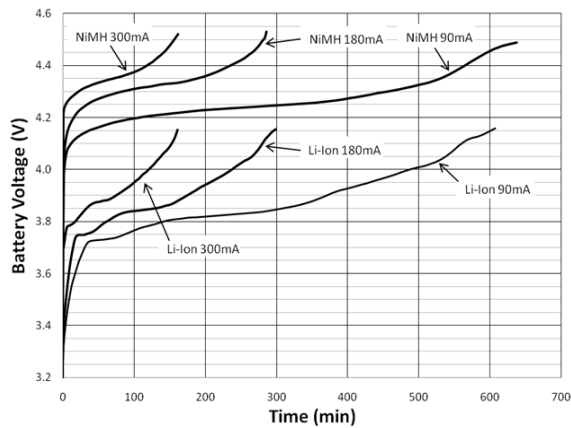

Figure 9. Battery Voltage vs. Time

Conclusion

In conclusion, a Constant Current Regulator, CCR, can be used to provide a constant current to a battery while charging. Furthermore, when the controller discussed here is implemented with a CCR it is possible to charge different battery chemistries at different currents with the same circuit.

References

- [1] [NSR10F20/D](#), “Schottky Barrier Diode”, Data Sheet, ON Semiconductor.
- [2] [NSS40200L/D](#), “40 V, 4.0 A, Low $V_{CE(sat)}$ PNP Transistor”, Data Sheet, ON Semiconductor.
- [3] [NSI45090DD/D](#), “Adjustable Constant Current Regulator & LED Driver”, Data Sheet, ON Semiconductor.
- [4] [LM211/D](#), “Single Comparators”, Data Sheet, ON Semiconductor.
- [5] [TL431/D](#), “Programmable Precision References”, Data Sheet, ON Semiconductor.
- [6] [MMBT3904LT1/D](#), “General Purpose Transistor”, Data Sheet, ON Semiconductor.
- [7] Battery University. “Charging Lithium-ion”.
http://batteryuniversity.com/learn/article/charging_lithium_ion_batteries
- [8] Battery University. “Charging Nickel-metal-hydride”.
http://batteryuniversity.com/learn/article/charging_nickel_metal_hydride
- [9] Battery University. “Charging Nickel-cadmium”.
http://batteryuniversity.com/learn/article/charging_nickel_based_batteries
- [10] TECHNIK. “Charging the Nickel-metal Hydride Battery”.
http://www.technik.net/public/code/cp_dpage.php?aiocp_dp=guide_bpw2_c04_05

AND9031/D

APPENDIX I – BILL OF MATERIALS FOR CCR CHARGING CIRCUIT DEMO BOARD

Qty	Location on PCB	Part No.	Description	Manufacturer
1	D ₁	NSR10F20NXT5G	DSN2 Low VF Schottky Diode	ON Semiconductor
1	Q ₃	NSS40200LT1G	Low VCE(sat) PNP Transistor	ON Semiconductor
1	Q ₆	MMBT3904LT1G	NPN Transistor	ON Semiconductor
1	Q ₂	LM311DG	Single Comparator	ON Semiconductor
1	Q ₁	TL431BCDG	Programmable Precision Reference	ON Semiconductor
1	Q ₄ , Q ₅	NSI45090JDT4G	90–160 mA CCR	ON Semiconductor
1	Q ₇	NSI45025AZT1G	25 mA CCR	ON Semiconductor
2	R ₄ , R ₅		1206 SMD Resistor, 1 kΩ 1/4 W 1%	
3	R ₁ , R ₂ , R ₃		0805 SMD Resistor, 1 kΩ 1/8 W 1%	
1	R ₆		0805 SMD Resistor, 5.6 kΩ 1/8 W 1%	
2	R _{adj1} , R _{adj2}		1210 SMD Resistor, 1/2 W 1%, value depends on design	
1	R _{ref}		0805 SMD Resistor, 1/8 W 1%, value depends on design	
1	R _h		0805 SMD Resistor, 1/8 W 1%, value depends on design	
1	LED		SMD 50 mA LED	
15	All TP's		Conn. Header	
1	V _{dc}	PJ-102A	Conn Jack Power 2.1 mm PCB	CUI Inc.
2	V _{in-} , V _{batt-}	571-0100	Banana Conn	Deltron
2	V _{in+} , V _{batt+}	571-0500	Banana Conn	Deltron

APPENDIX II – PCB LAYOUT OF CCR CHARGING CIRCUIT DEMO BOARD

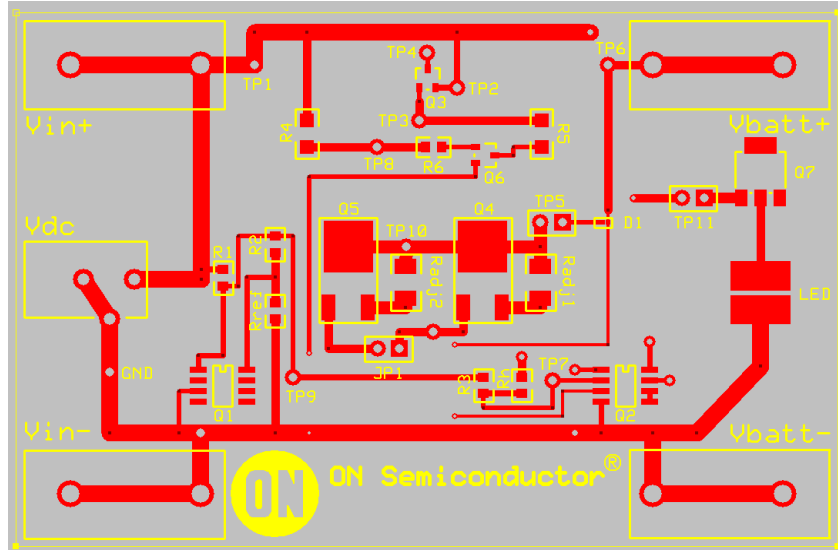

Figure 10. Top Layer Copper and Silkscreen

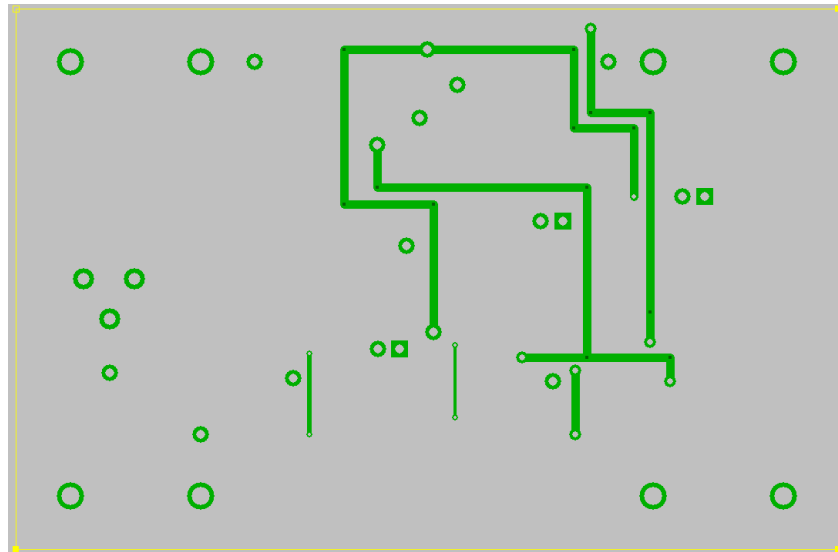



Figure 11. Bottom Layer Copper

ON Semiconductor and  are trademarks of Semiconductor Components Industries, LLC dba ON Semiconductor or its subsidiaries in the United States and/or other countries. ON Semiconductor owns the rights to a number of patents, trademarks, copyrights, trade secrets, and other intellectual property. A listing of ON Semiconductor's product/patent coverage may be accessed at www.onsemi.com/site/pdf/Patent-Marking.pdf. ON Semiconductor reserves the right to make changes without further notice to any products herein. ON Semiconductor makes no warranty, representation or guarantee regarding the suitability of its products for any particular purpose, nor does ON Semiconductor assume any liability arising out of the application or use of any product or circuit, and specifically disclaims any and all liability, including without limitation special, consequential or incidental damages. Buyer is responsible for its products and applications using ON Semiconductor products, including compliance with all laws, regulations and safety requirements or standards, regardless of any support or applications information provided by ON Semiconductor. "Typical" parameters which may be provided in ON Semiconductor data sheets and/or specifications can and do vary in different applications and actual performance may vary over time. All operating parameters, including "Typicals" must be validated for each customer application by customer's technical experts. ON Semiconductor does not convey any license under its patent rights nor the rights of others. ON Semiconductor products are not designed, intended, or authorized for use as a critical component in life support systems or any FDA Class 3 medical devices or medical devices with a same or similar classification in a foreign jurisdiction or any devices intended for implantation in the human body. Should Buyer purchase or use ON Semiconductor products for any such unintended or unauthorized application, Buyer shall indemnify and hold ON Semiconductor and its officers, employees, subsidiaries, affiliates, and distributors harmless against all claims, costs, damages, and expenses, and reasonable attorney fees arising out of, directly or indirectly, any claim of personal injury or death associated with such unintended or unauthorized use, even if such claim alleges that ON Semiconductor was negligent regarding the design or manufacture of the part. ON Semiconductor is an Equal Opportunity/Affirmative Action Employer. This literature is subject to all applicable copyright laws and is not for resale in any manner.

PUBLICATION ORDERING INFORMATION

LITERATURE FULFILLMENT:
 Literature Distribution Center for ON Semiconductor
 19521 E. 32nd Pkwy, Aurora, Colorado 80011 USA
Phone: 303-675-2175 or 800-344-3860 Toll Free USA/Canada
Fax: 303-675-2176 or 800-344-3867 Toll Free USA/Canada
Email: orderlit@onsemi.com

N. American Technical Support: 800-282-9855 Toll Free
 USA/Canada
Europe, Middle East and Africa Technical Support:
 Phone: 421 33 790 2910
Japan Customer Focus Center
 Phone: 81-3-5817-1050

ON Semiconductor Website: www.onsemi.com
Order Literature: <http://www.onsemi.com/orderlit>
 For additional information, please contact your local Sales Representative